

**UPDATE NOTES:  
01-25-2024**

Please note, the ONLY update since this document's previous version (published on 07-14-2023) are the (Supplemental Guidelines for Section 60).

Be sure to download the full  
"Residential Development Standards - Parkland (01-25-2024)"

Available on the Bridgeland Residential page at  
[www.KenAnderson.com](http://www.KenAnderson.com)

New Update(s)  
to these Residential Standards  
can be found on the following page(s)  
and  
will be highlighted in  
light blue.

# **SUPPLEMENTAL GUIDELINES**

**PARKLAND**

**60**

## DISCLAIMER

Placement of these amended items in the Bridgeland New Construction as well as confirmation of the accuracy and completeness of this document are to be solely determined by Bridgeland Development. All items and requirements not included in this Supplemental Guidelines will defer to the requirements of the Bridgeland New Construction Development Standards for Parkland Village.

## **Bridgeland – New Construction – Supplemental Guidelines (Parkland - Section 60)**

### **I. ARCHITECTURAL STYLE**

Parkland – Section 60 will utilize Traditional and a Modern Farmhouse style of architecture.

#### **A. Individual Elements & Materials**

##### **1. Masonry**

The use of masonry (brick, stone, stucco) shall be used as the primary materials for all homes on the 1<sup>st</sup> floor. The use of painted brick may be approved within the architectural style of the section on a case-by-case basis as determined by the ARC. Full masonry is not required on the 2<sup>nd</sup> or 3<sup>rd</sup> floor of the front elevation.

*(See section "II. PLAN REPETITION & USE RESTRICTIONS")*

##### **2. Siding**

Where used, the siding, stucco, shingles, board & batten material shall be a cementitious material. These materials shall be of horizontal, lap type, excluding board & batten which shall be vertical and may be used on an 2<sup>nd</sup> and 3<sup>rd</sup> floor elevations of the home, including homes on amenity lots and corner lots.

Siding shall be painted with medium range colors. The use of wood, particle board, or any sheet siding is prohibited. Vinyl or aluminum siding is also prohibited.

##### **3. Wing Wall, Steps & Sidewalks**

No wing walls or steps will be used in Parkland – Section 60.

###### **a) Private Walkways**

A four (4') foot paver walkway shall lead from the front main entry of the home to the shared/courtyard driveway.

###### **b) Public Sidewalks**

A five (5') foot sidewalk is required offset eight (8') feet from the back of curb across the front of the lot, and at the side street on corner lots. The builder installed public sidewalks will connect to portions of existing sidewalks.

Per TDLR standards, Sidewalks shall not have a side slope greater than two (2%) percent and a running slope greater than five (5%) percent.

*(See attached Exhibits: "PV60-B", "PV60-C" & "PV60-F.1")*

#### **4. Driveways**

Driveway locations are set forth by the plan design and lot layout. All driveway designs are subject to review by the ARC.

##### **a) Driveway Responsibility/Construction**

Builders are required to install a paver driveway from the garage to a shared/courtyard driveway. The builder installed shared/courtyard driveway will consist of the same pavers as the driveway aprons to the garage and extend to the R.O.W., which will transition to an existing concrete inturn from the street.

*(See attached Exhibits: "PV60-F.1" & "PV60-F.2")*

##### **b) Driveway Widths**

Driveways shall be sixteen (16') feet in width.

#### **B. Square Footage**

The allowable livable house square footage is as follows:

- 1,400 sqft. (Minimum)
- 2,100 sqft. (Maximum)

#### **C. Building Setbacks**

*(See attached Exhibit: "PV60-A")*

#### **D. Fences**

##### **1. Fence Types**

Three (3) fence types shall be used in this section:

- Five (5') foot 'Standard' fencing.
- Five (5') foot 'Enhanced' fencing.
- Six (6') foot Brick Thin Wall (Developer installed fence)

*(See attached Exhibit: "PV60-D")*

*(Section Fence & Driveway Layouts are available at [www.KenAnderson.com](http://www.KenAnderson.com))*

##### **2. Locations**

##### **a) Front Fences**

Front fences that face or are adjacent to a public street shall be set back a minimum of 5' and a maximum of 15' from the front corner of the home, unless there are conflicts with windows or

other architectural elements of the house. Front fences that are located on the courtyard side or on rear platted units shall be set back a minimum of 2' and a maximum of 15' from the front corner of the home, unless there are conflicts with windows or other architectural elements of the house.

**b) Side Fences (Interior)**

Side fences along interior property lines will be on the property line.

**c) Side Fence (Street Side – Corner Lot)**

At the street side of corner lots, a minimum side fence setback of three (3') feet from the public sidewalk.

*(See attached Exhibits: "PV60-B" & "PV60-C")*

## **II. PLAN REPETITION & USE RESTRICTIONS**

A residential structure plan and elevation repetition should have the following separations:

- A.** In Parkland Section 60 the repetition and locations of plans and elevation has been determined in advance.

*(See attached Exhibit: "PV60-E")*

## **III. LANDSCAPING**

Full irrigation required for all trees, plantings and turf. Sod shall be 'Tifway 419' Bermuda.

**A. Front Yard**

**1. Street Tree(s)**

This section will not include street trees.

**2. Shade Tree(s)**

This section will not include front yard shade trees.

**3. Ornamental Tree(s)**

This section will include two (2) ornamental trees in the front yard.

*(See attached Exhibit: "PV60-B")*

**B. Side Yard (Street Side – Corner Lots)**

A continuous evergreen foundation hedge shall run the length of the exterior face of the side fence. Plant material is required to be a minimum of five (5) gallons and 24"-30" inches tall at installation. Approved plants are: Wax Myrtle, Oleander, Elaeagnus, Ligustrum (shrub form) or Burford Holly. Additional shrubs shall be used along the foundation of the home.

*(See attached Exhibit: "PV60-C")*

**C. Rear Yard**

Rear yards shall include one (1) shade tree or two (2) ornamental trees.

*(See attached Exhibit: "PV60-B")*

# BUILDING SETBACKS - ("QUADS") - TYPICAL

SCALE: NTS

# PV60-A

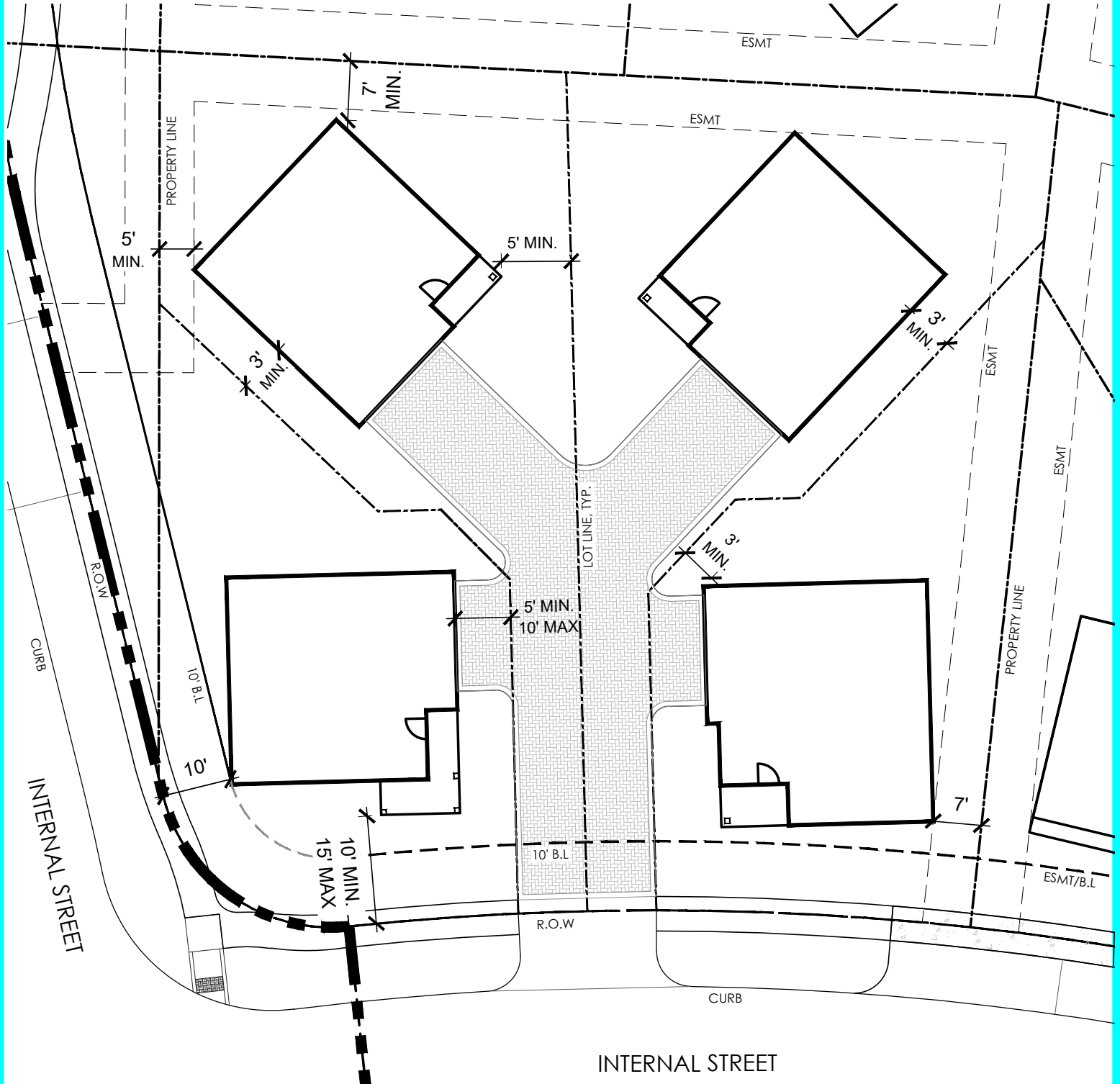

## SETBACKS:

**FRONT:** 10'-0" MINIMUM (INCLUDING PORCH)  
15'-0" MAXIMUM

**SIDE:** 3'-0" MINIMUM (SEE EXHIBIT ABOVE)

**REAR:** 7'-0" MINIMUM

**ATTACHED GARAGE:** 5'-0" MINIMUM | 10'-0" MAXIMUM

# LANDSCAPING REQUIREMENTS - ("QUADS") - TYPICAL

SCALE: NTS

# PV60-B

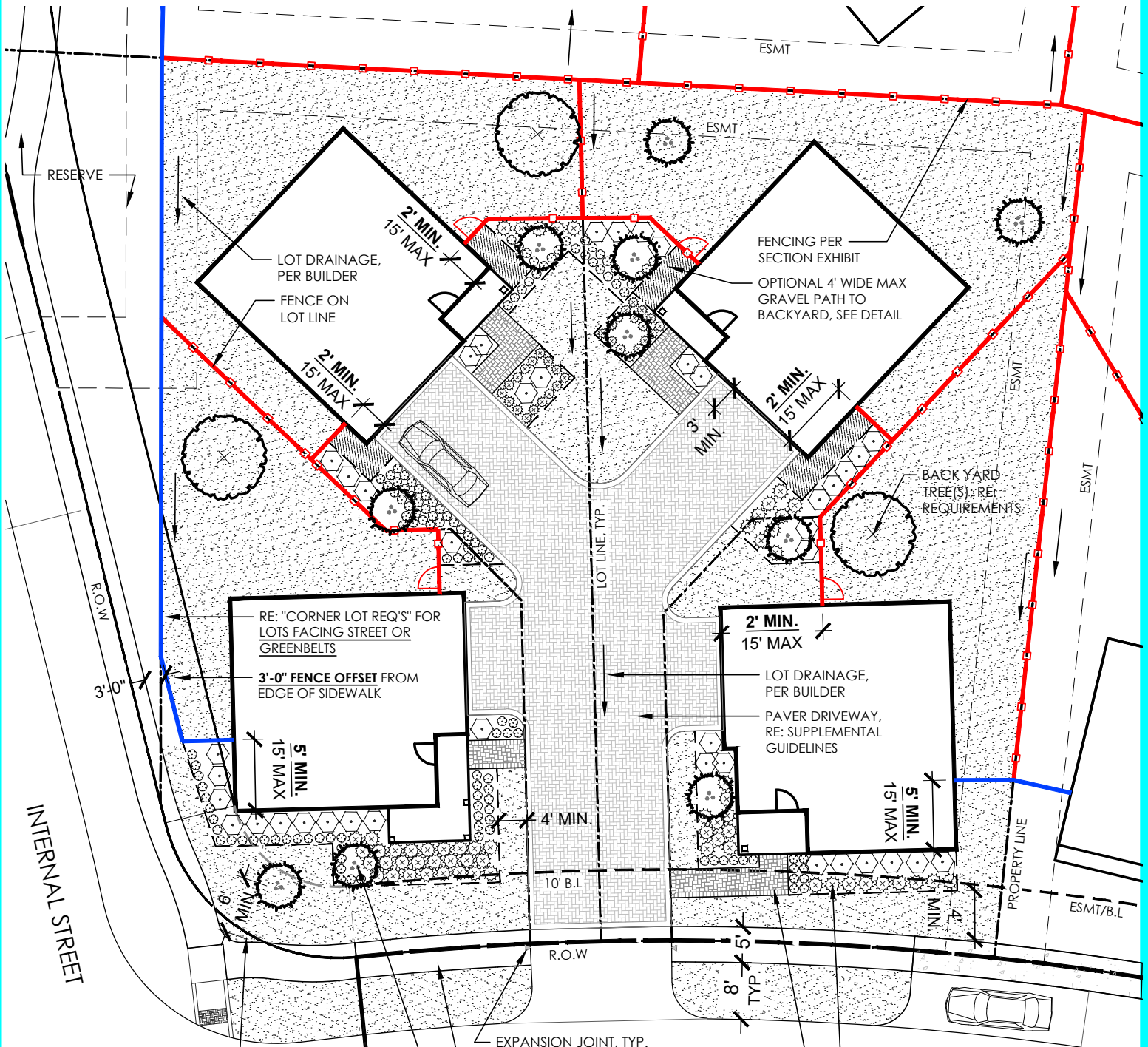

TREES SHALL NOT BE PLANTED ANY CLOSER THAN 6'-0" FROM EDGE OF WALK OR DRIVEWAY, TYP.

EXPANSION JOINT, TYP.  
 5' WIDE CONCRETE PUBLIC WALK, BROOM FINISH (NO PICTURE FRAME)  
 2% MAX CROSS SLOPE, 5% MAX RUNNING SLOPE  
 REQUIRED FRONT YARD ORN. TREES; (MAY BE SUBSTITUTED W/ SHADE TREE IF ADEQUATE SPACE PROVIDED)

PLANTER BED COVERAGE, RE: LANDSCAPE REQUIREMENTS THIS EXHIBIT  
 4' WIDE PAVER WALKWAY, BY BUILDER (SEE SUPPLEMENTAL DETAILS)

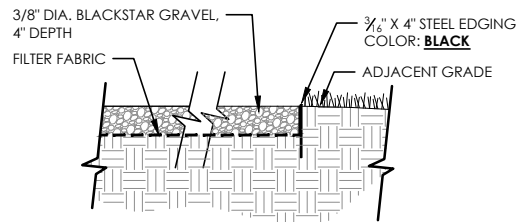

**A** GRAVEL PATH W/ STEEL EDGING SECTION NTS

**NOTES:**

- REFERENCE PARKLAND VILLAGE 'NEW CONSTRUCTION DEVELOPMENT STANDARDS' FOR APPROVED PLANTING LIST.
- FOR SIDE YARDS AND CORNER LOTS FACING GREENBELTS OR STREET R.O.W., REFERENCE PARKLAND VILLAGE 'NEW CONSTRUCTION DEVELOPMENT STANDARDS' FOR PLANTING REQUIREMENTS.
- FULL IRRIGATION REQUIRED FOR ALL TREES, PLANTING & TURF.
- SOLID SOD SHALL BE TIFWAY 419' BERMUDA.
- APPROVED SHADE TREE SPECIES PER PARKLAND VILLAGE GUIDELINES.
- APPROVED ORNAMENTAL TREE SPECIES:
  - FRONT YARD:** LITTLE GEM MAGNOLIA, \*CRAPE MYRTLE SPP., EAGLESTON HOLLY OR VITEX.
  - BACK YARD:** EAGLESTON HOLLY OR \*CRAPE MYRTLE SPP.
- NO COLUMNS OF WING WALLS REQUIRED.
- NO STREET TREES REQUIRED.
- UTILITIES TO BE SCREENED FROM BOTH NEIGHBOR & STREET R.O.W.

**LOT REQUIREMENTS**

| ITEM                   | QUANTITY/ LENGTH                                     |
|------------------------|--|
| FRONT YARD SHADE TREES | NONE   |
| FRONT ORNAM. TREES     | 2 (30 GAL. MIN.)                                     |
| PLANTER BED COVERAGE   | 40% MIN.   |
| WING WALLS             | NONE   |
| REAR YARD TREES        | 1 - SHADE TREE (65 GAL.) OR 2 - ORN. TREES (30 GAL.) |

**\*APPROVED CRAPE MYRTLE VARIETIES:**  
 'NATCHEZ' | 'GLEN DORA WHITE' | 'FANTASY' | 'KIOWA' | 'SARAH'S FAVORITE' | 'TOWNHOUSE' | 'ARAPAHO' | 'RED ROCKET' | 'BLOXI' | 'CHOCTAW' | 'POTOMAC' | 'MUSKOGEE' | 'TWILIGHT'



# CORNER LOT REQUIREMENTS - TYPICAL

SCALE: NTS

PV60-C

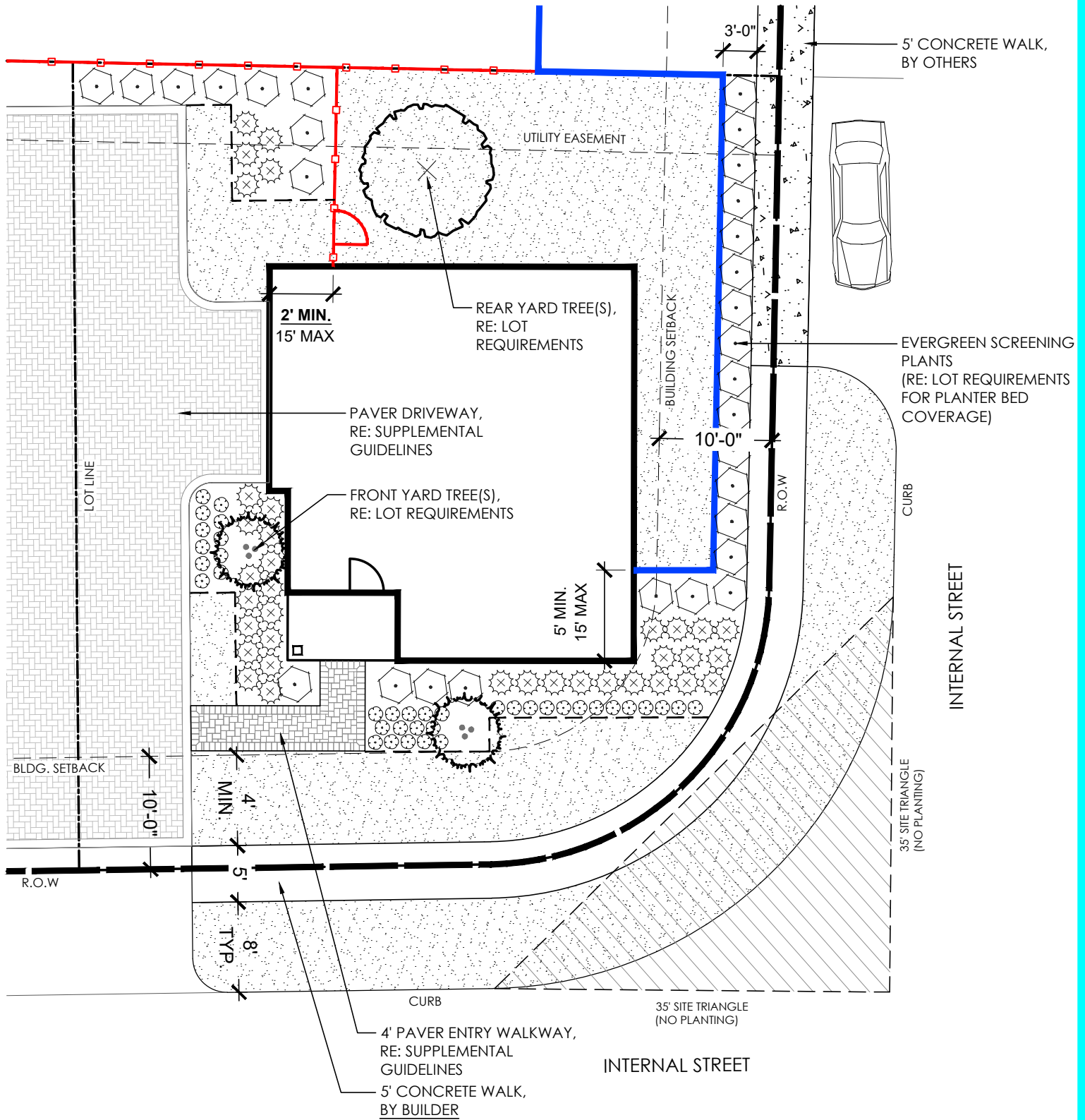

- NOTES:
1. REFERENCE PARKLAND VILLAGE 'NEW CONSTRUCTION DEVELOPMENT STANDARDS' FOR APPROVED PLANTING LIST.
  2. FULL IRRIGATION REQUIRED FOR ALL TREES, PLANTING & TURF.
  3. SOLID SOD SHALL BE 'TIFWAY 419' BERMUDA.
  4. APPROVED TREE SPECIES PER PARKLAND VILLAGE GUIDELINES.
  5. NO COLUMNS or WING WALLS REQUIRED.
  6. NO STREET TREES REQUIRED.
  7. UTILITIES TO BE SCREENED FROM BOTH NEIGHBOR & STREET R.O.W.
  8. PLANTING SHALL NOT IMPEDE LOT DRAINAGE.

| CORNER LOT REQUIREMENTS |   |
|-------------------------|---|
| ITEM                    | QUANTITY/ LENGTH                        |
| SIDE YARD SHADE TREES   | NONE                                    |
| SIDE YARD ORN. TREES    | NONE                                    |
| REAR YARD TREES         | *1 - SHADE TREE<br>OR<br>2 - ORN. TREES |

\*IF SHADE TREE, PLANT IN REAR YARD OPPOSITE OF STREET SIDE.

Section Fence & Driveway Layouts are available at [www.KenAnderson.com](http://www.KenAnderson.com)

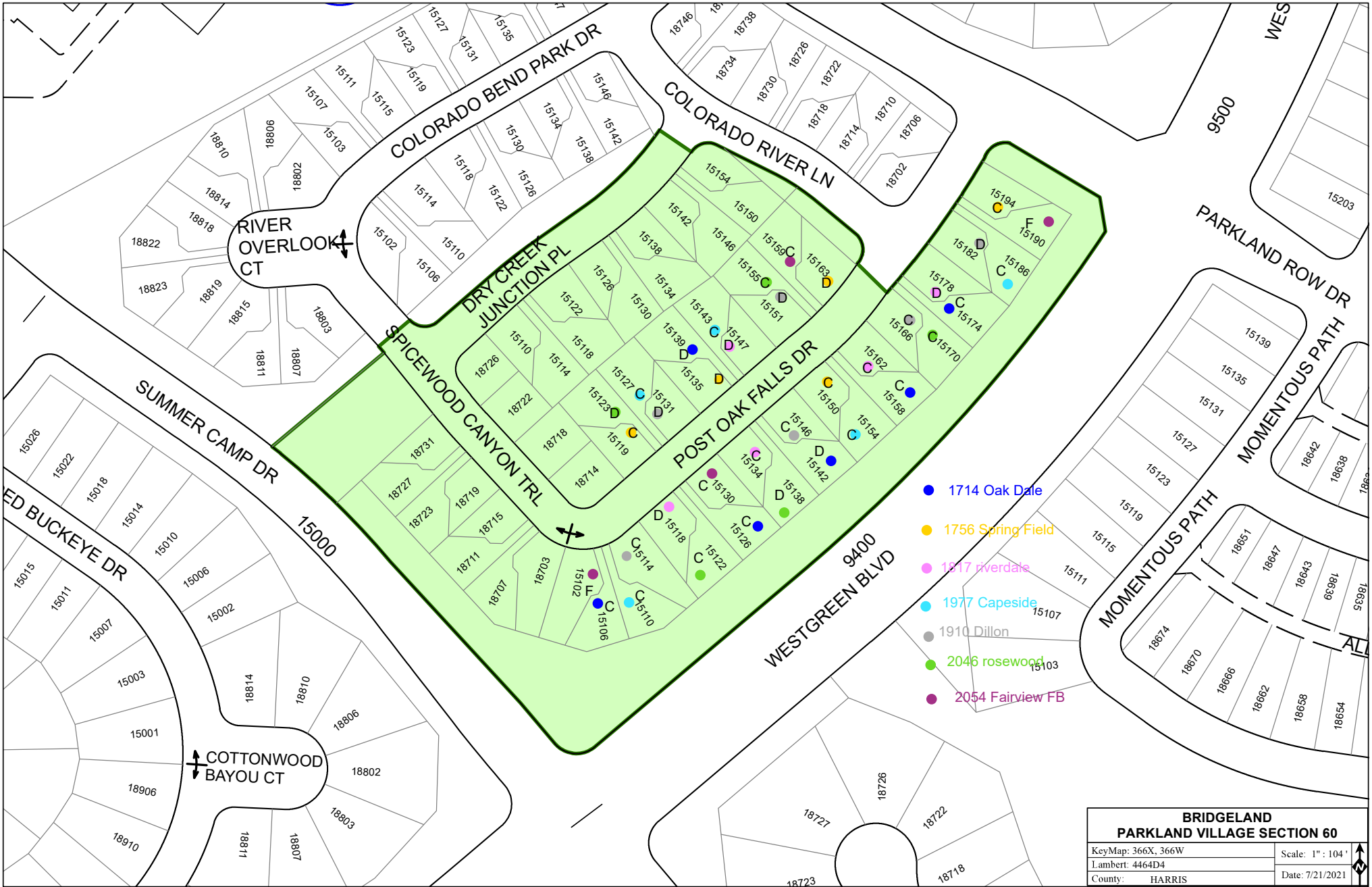

| BRIDGELAND<br>PARKLAND VILLAGE SECTION 60 |                  |  |
|---|------------------|--|
| KeyMap: 366X, 366W                        | Scale: 1" = 104' |  |
| Lambert: 4464D4                           | Date: 7/21/2021  |  |
| County: HARRIS                            |                  |  |

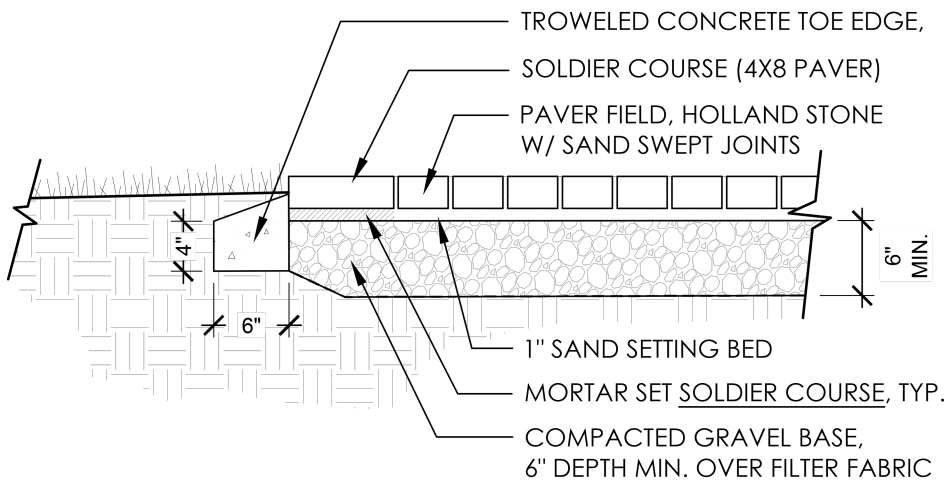

**HOLLAND STONE**

4 x 8 x 2-3/8" (60 MM)

COLOR /BLEND: CHARCOAL

PATTERN: HERRINGBONE



MANUFACTURER: BELGARD

**PAVER DRIVEWAY & ENTRY PATHWAY**

DETAIL

NTS

# DRIVEWAY REQUIREMENTS: PAVER DRIVEWAY LAYOUT - TYPICAL

SCALE: NTS

# PV60-F2

**NOTE:**

SEE SUPPLEMENTAL GUIDELINES FOR ENTRY PATHWAY & FRONT YARD PLANTING REQUIREMENTS.

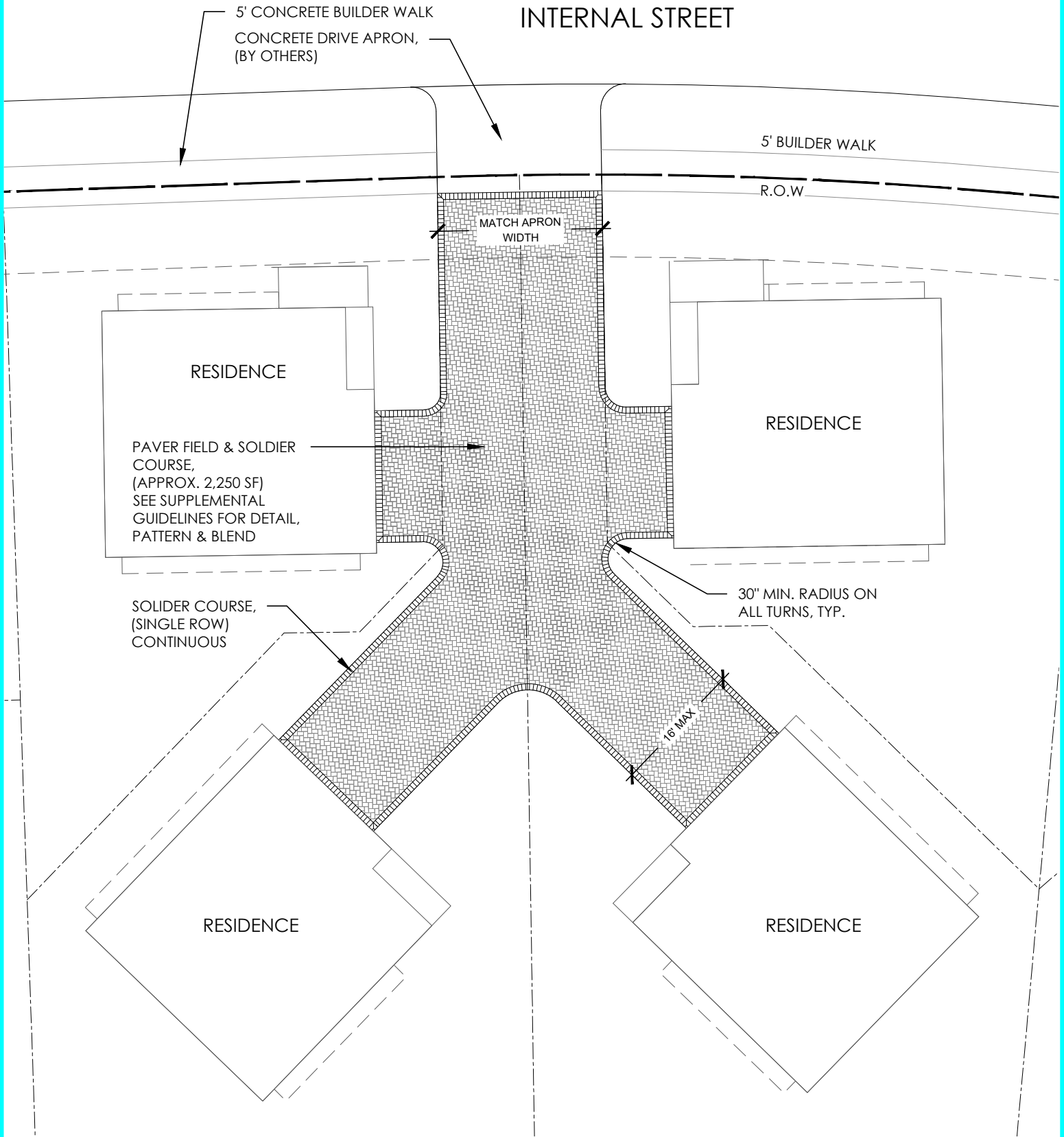

# **SUPPLEMENTAL GUIDELINES**

**PARKLAND**

**55**



- 1474 Storybrook—FB ●
- 1714 Oakdale B ●
- 1756 Springfield F ●
- 1817 Riverdale F ●
- 1907 Hawkins FB ●
- 1977 Capeside B ●
- 2054 Fairview FB ●
- 1910 Dillion F ●
- 2046 Rosewood B ●

**M** Model Homes

The following pages were included in  
PREVIOUS "Update Notes" for these  
Residential Standards.



# **SUPPLEMENTAL GUIDELINES**

**PARKLAND**

**56**

**(45' LOTS)**

## DISCLAIMER

Placement of these Supplemental Guidelines in the Bridgeland New Construction, as well as confirmation of the accuracy and completeness of this document, are to be solely determined by Bridgeland Development. All items and requirements not included in these Supplemental Guidelines will defer to the requirements of the Bridgeland New Construction Development Standards for Parkland Village.)

## **Bridgeland – New Construction – Supplemental Guidelines (Parkland – Section 56)**

### **I. ARCHITECTURAL STYLE**

Parkland – Section 56 shall be a transitional and/or modern style of architecture as approved by the ARC.

#### **A. Individual Elements & Materials**

##### **1. Siding**

Cementitious siding and/or board & batten can be used, as approved on a case-by-case basis by the ARC, in this section as long as it is in harmony with the architectural style and character of the home. Siding shall be of horizontal, lap type, excluding board & batten, which shall be vertical. These materials may not be used on the 1<sup>st</sup> floor, side, or rear elevations of the home, including homes on amenity lots and corner lots.

Siding shall be painted with colors from a pallet predetermined by the ARC. The use of wood, particle board, vinyl, aluminum, or any sheet siding is prohibited.

##### **2. Masonry**

The use of masonry (brick, stone, stucco), as well as painted brick, may be approved within the architectural style of this section on a case-by-case basis as determined by the ARC. Full masonry is required on the 1st floor of side and rear elevations. Wainscoting may be used on the front elevation.

##### **3. Doors**

Colored front doors will be allowed on a case-by-case basis as determined by the ARC. Front doors with natural wood stains are permitted.

##### **4. Wing Wall, Steps & Sidewalks**

No wing walls or steps will be used in Parkland – Section 56.

Front private entry walks shall lead from the front main entry of the home to the driveway and be installed by the Builder per the New Construction Development Standards. Front entry walks may not be connected to the public sidewalk or the street curb. Continuous decorative pavers shall be used for the entire surface of the private front entry walks.

*(See attached PV56-Exhibit: "A")*

##### **5. Driveways**

Driveway locations are as depicted on the Section Fencing & Driveway Layout Exhibit. The ARC may grant variances to site-specific situations as it deems appropriate. All driveway designs are subject to review by the ARC. Driveways shall typically cross the building setback area in a straight line at a ninety (90) degree angle to the street right-of-way.

**a) Driveway Responsibility/Construction**

Builders are required to build the driveway out to the street. Most lots have a mountable curb at the street. Driveways are to be a minimum of three and one-half inches (3.5") thick over a sand base. Six by six (6x6) woven wire mesh shall be installed within the apron of the driveway as a minimum. Expansion joints between the curb and driveway are required as illustrated. Where barrier curbs exist, saw cut into existing street and dowel into existing concrete paving. Where the driveways intersect the sidewalk and front walks, the driveway finish may not continue through the sidewalk. The radius at the curb shall be five feet (as necessary to meet sidewalk edge). Sidewalks shall not have a side slope greater than two (2%) percent and a running slope greater than five (5%) percent.

**b) Driveway Widths**

Driveways serving two-car garages with a single garage door, facing the street, shall be:

- **Minimum Width:**  
Twelve feet (12')
- **Maximum Width:**  
Sixteen feet (16')

**B. Square Footage**

The allowable livable house square footage is as follows:

- 1,400 sqft. (Minimum)
- 2,600 sqft. (Maximum)

**C. Fences**

**1. Fence Types**

Three (3) fence types shall be used in this section:

- Five (5') foot tubular steel fencing.
- Six (6') foot double-sided wood fence – capped.
- Six (6') foot, single wythe, brick masonry.

**2. Fence Locations**

*Section Fence & Driveway Layouts are available at [www.KenAnderson.com](http://www.KenAnderson.com)*

# LOT REQUIREMENTS: 45'

# (PARKLAND - SECTION 56)

# PV56-A

SCALE: NTS

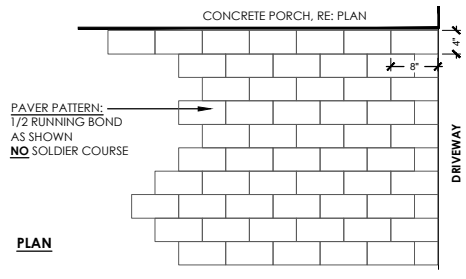
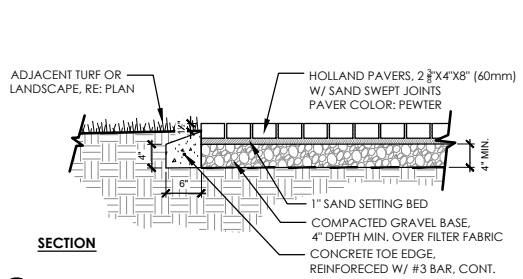
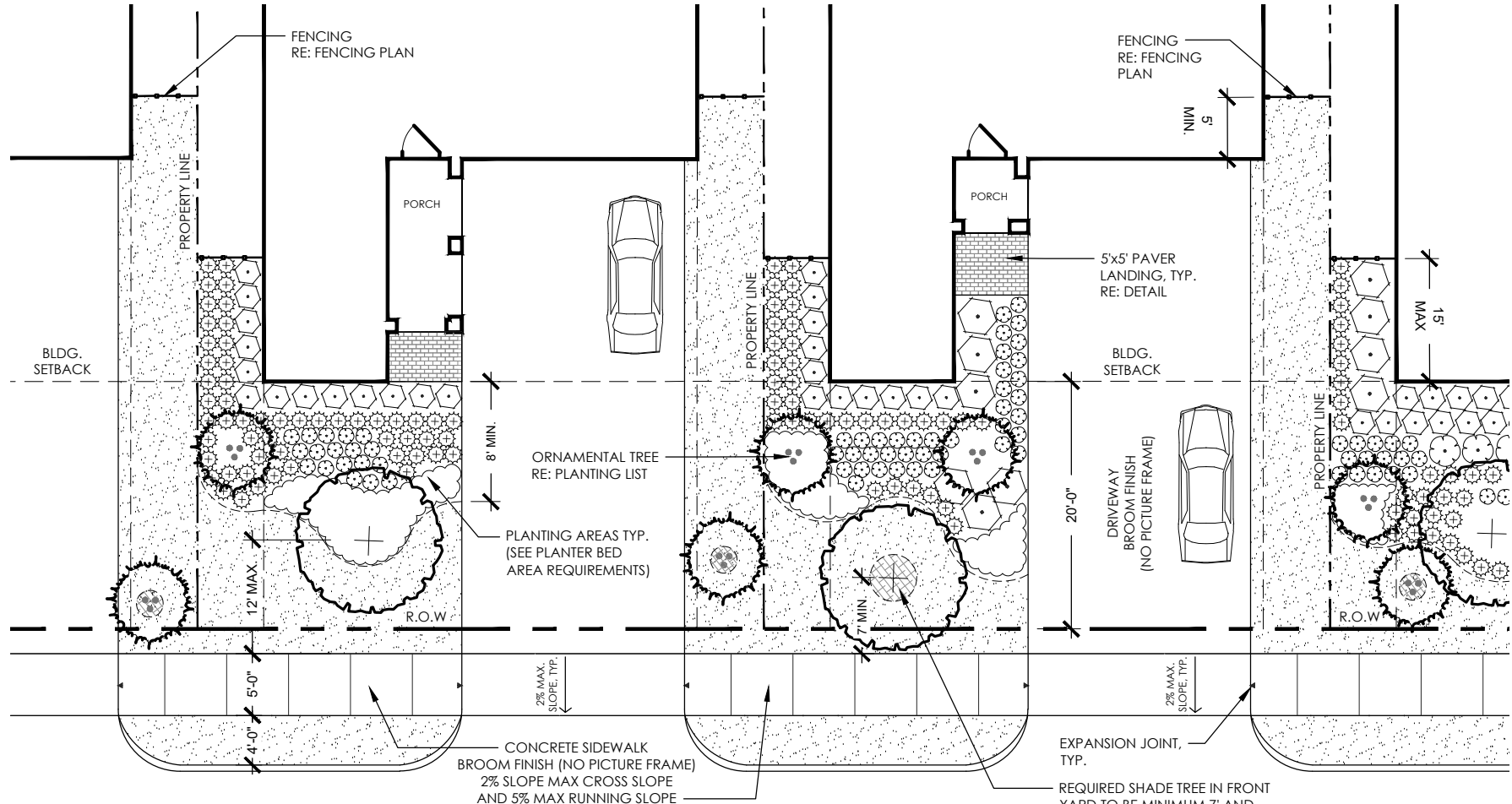

- NOTES:**
1. REFERENCE PARKLAND VILLAGE 'NEW CONSTRUCTION DEVELOPMENT STANDARDS' FOR APPROVED PLANTING LIST.
  2. FOR SIDE YARDS AND CORNER LOTS FACING GREENBELTS OR STREET R.O.W. REFERENCE PARKLAND VILLAGE 'NEW CONSTRUCTION DEVELOPMENT STANDARDS' FOR PLANTING REQUIREMENTS.
  3. FRONT YARD TO REQUIRE FULL IRRIGATION.
  4. SOG SHALL BE TIFWAY 419 BERMUDA.
  5. SHADE TREES IN REAR YARD TO COMPLY WITH LAKELAND VILLAGE 'NEW CONSTRUCTION DEVELOPMENT STANDARDS'.
  6. NO COLUMNS, WING WALLS OR DECORATIVE FENCING REQUIRED.
  7. NO STREET TREES REQUIRED.

| LOT REQUIREMENTS: 45' & LOWER                |                  |
|--|------------------|
| ITEM   | QUANTITY/ LENGTH |
| FRONT YARD SHADE TREES                       | 1 (3' CAL. MIN.) |
| ORNAMENTAL TREE                              | 2                |
| PLANTER BED COVERAGE                         | 40%              |
| WING WALLS                                   | NONE             |
| REAR YARD SHADE TREES                        | 1                |
| REAR YARD ORNAMENTAL TREES (ON AMENITY LOTS) | 1                |

**A** PAVER ENTRY WALK

PLAN / SECTION  
NTS

# **SUPPLEMENTAL GUIDELINES**

## **SECTION**

# **20**

## DISCLAIMER

Placement of these amended items in the Bridgeland New Construction as well as confirmation of the accuracy and completeness of this document are to be solely determined by Bridgeland Development. All items and requirements not included in these Supplemental Guidelines will defer to the requirements of the Bridgeland New Construction Development Standards for Parkland Village.)

## **Bridgeland – New Construction – Supplemental Guidelines (Parkland - Section 20)**

### **I. ARCHITECTURAL STYLE**

Parkland - Section 20 is a custom home section.

In general, it is not the intent of these standards to dictate specific architectural styles that must be used within the Parkland - Section 20, but rather to give property owners and their architects or designers a set of guidelines that will provide flexibility while achieving continuity and harmony within this section of Bridgeland.

While it is desirable for the homes within Parkland - Section 20 to exhibit the individuality of their owners, designers are encouraged to develop an authenticity to the detailing of the house design based upon the architectural style of the home.

#### **A. Materials**

##### **1. Roofs**

- **Shingles**

Roof shingles (flat or barreled) shall be clay, slate or concrete and be within the architectural style of the home. Roof colors, such as blue, green, red, etc. are prohibited.

- **Metal**

Standing seam roofs will be approved on a case-by-case basis by the ARC. The use of Galvalume is prohibited.

##### **2. Wing Walls & Steps**

Wing Walls and/or Steps are not required to be used in Parkland - Section 20.

##### **3. Driveways & Private Walkways**

Driveways and private walkways in this section may use decorative pavers or stone consistent with the architectural style of the home.

##### **4. Doors**

Colored front doors shall be consistent with the architectural style of the home. Non-standard colors (non-earth tone) must be submitted for approval prior to installation.

### **II. SETBACK**

The amended front setback for this Section is:

- Twenty (20') feet (Minimum)
- Twenty-five (25') feet (Maximum)

## **A. Fences**

### **1. Fence Types**

Two (2) fence types shall be used in this section:

- Five (5') foot tubular steel fencing.
- Six (6') foot brick thin wall.

The use of wood fencing is prohibited in this Section.

*(See "FENCING AND DRIVEWAY LOCATION DIAGRAM")*

# **SUPPLEMENTAL GUIDELINES**

## **PARKLAND**

# **30**



## DISCLAIMER

Placement of these amended items in the Bridgeland New Construction as well as confirmation of the accuracy and completeness of this document are to be solely determined by Bridgeland Development. All items and requirements not included in this Supplemental Guidelines will defer to the requirements of the Bridgeland New Construction Development Standards for Parkland Village.)

## **Bridgeland – New Construction – Supplemental Guidelines (Parkland - Section 30)**

### **I. ARCHITECTURAL STYLE**

Parkland – Section 30 will utilize a traditional style of architecture.

#### **A. Individual Elements & Materials**

##### **1. Masonry**

The front elevation of the all homes shall be primarily masonry (brick, stone, stucco).

Full masonry is not required on the 1st floor unless stated in these Supplemental Guidelines.

*(See section “II. PLAN REPETITION & USE RESTRICTIONS”)*

The use of masonry (brick, stone, stucco) as well as painted brick may be approved within the architectural style of this section on a case-by-case basis as determined by the ARC.

##### **2. Siding**

Where used, the siding, stucco, shingles, board & batten material shall be a cementitious material. These materials shall be of horizontal, lap type, excluding board & batten which shall be vertical.

Siding shall be painted with medium range colors. The use of wood, particle board, or any sheet siding is prohibited. Vinyl or aluminum siding is also prohibited.

##### **3. Wing Wall, Steps & Sidewalks**

No wing walls or steps will be used in Parkland – Section 30.

Front private entry walks shall lead from the front main entry of the home to the driveway and be installed by Builder per the New Construction Development Standards. Front entry walks may not be connected to the public sidewalk or the street curb. Continuous decorative pavers shall be used for the entire surface of the private front entry walks.

*(See attached Exhibit: “PV30-B”)*

##### **4. Driveways**

Driveway locations are set forth by the plan design and lot layout. The ARC may grant variances to site specific situations as it deems appropriate. All driveway designs are subject to review by the ARC. Driveways shall typically cross the building setback area in a straight line at a ninety (90) degree angle to the street right-of-way.

##### **a) Driveway Responsibility/Construction**

Builders are required to build the driveway out to the street. Most lots have a mountable curb at the street. Driveways are to be a minimum of three and one-half inches (3.5”) thick over a sand base. Six by six (6x6) woven wire mesh shall be installed within the apron of the driveway as a minimum. Expansion joints between the curb and driveway are required as illustrated. Where barrier curbs exist, saw cut into existing street and dowel into existing concrete paving. Where

the driveways intersect the sidewalk and front walks, the driveway finish may not continue through the sidewalk. The radius at the curb shall be five feet (as necessary to meet sidewalk edge). Sidewalks shall not have a side slope greater than two (2%) percent and a running slope greater than five (5%) percent.

**b) Driveway Widths**

Driveways serving two car garages with a single garage door, facing the street, shall be:

- **Minimum Width:**  
Twelve feet (12')
- **Maximum Width:**  
Sixteen feet (16')

**B. Square Footage**

The allowable livable house square footage is as follows:

- 1,600 sqft. (Minimum)
- 2,100 sqft. (Maximum)

**C. Fences**

**1. Fence Types**

Three (3) fence types shall be used in this section:

- Five (5') foot tubular steel fencing.
- Six (6') foot double sided wood fence – capped.
- Six (6') foot Brick Thin Wall (Developer installed fence)

*(See attached Exhibit: "PV30-C")*

**2. Locations**

**a) Front Fences**

Front fences shall be set back a minimum of 5' and a maximum of 15' from the front corner of the entry unless there are conflicts with windows or other architectural elements of the house.

**b) Side Fences (Interior)**

Side fences along interior property lines will be on the property line. Front fences, on the interior side of a corner lot, which are more than ten (10') feet long require a planting buffer.

**c) Side Fence (Street Side – Corner Lot)**

At the street side of corner lots, a minimum side fence setback of three (3') feet from property line.

## II. PLAN REPETITION & USE RESTRICTIONS

A residential structure plan and elevation repetition should have the following separations:

- A. In Parkland Section 30 the repetition and locations of plans and elevation has been determined in advance.

*(See attached Exhibit: “PV30-D”)*

- B. Due to mid-level placement of side elevation windows on plans with split-level entries, masonry on the first floor of side elevations are not visually ideal for lots with higher public visibility. Therefore, plans with split-level entries may not be placed on lots 1, 31, 40 or 42.

## III. LANDSCAPING

### A. Front Yard

#### 1. Street Tree(s)

This section will not include street trees. Instead the required trees have been moved further into the lot.

#### 2. Shade Tree(s)

A minimum of one (1) three and a half inch (3.5") caliper shade tree is required in front yards on all lots. Installed a minimum of seven (7') feet and a maximum of twelve (12') feet from the public sidewalk.

#### 3. Ornamental Tree(s)

This section will include ornamental trees in the front driveway planter.

*(See attached Exhibit: “PV30-B”)*

### B. Side Yard (Street Side – Corner Lots)

A continuous evergreen foundation hedge shall run the length of the exterior face of the side fence. Plant material is required to be a minimum of five (5) gallons and 24"-30" inches tall at installation. Approved plants are: Wax Myrtle, Oleander, Elaeagnus, Ligustrum (shrub form) or Burford Holly. Additional shrubs shall be used along the foundation of the home.

*(See attached Exhibit: “PV30-E2”)*

### C. Rear Yard (Amenity Lots & Corner Lots)

Landscape planting and irrigation are required in all Rear Yards.

*(See attached Exhibit: “PV30-E5”)*

# LOT REQUIREMENTS: 28' - (PARKLAND - SECTION 30)

SCALE: NTS

# PV30-B

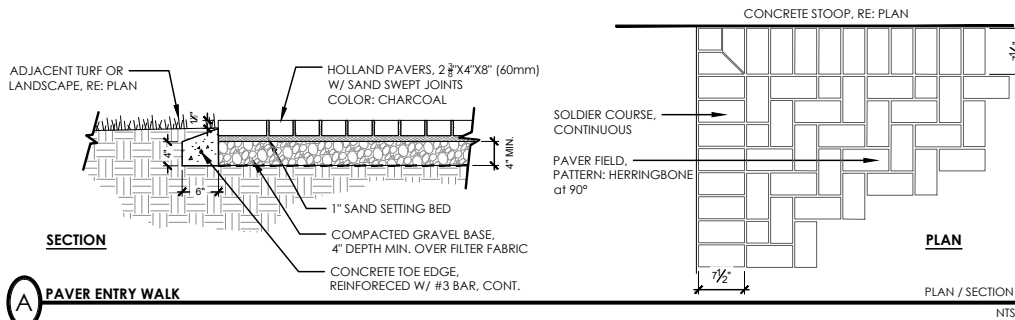
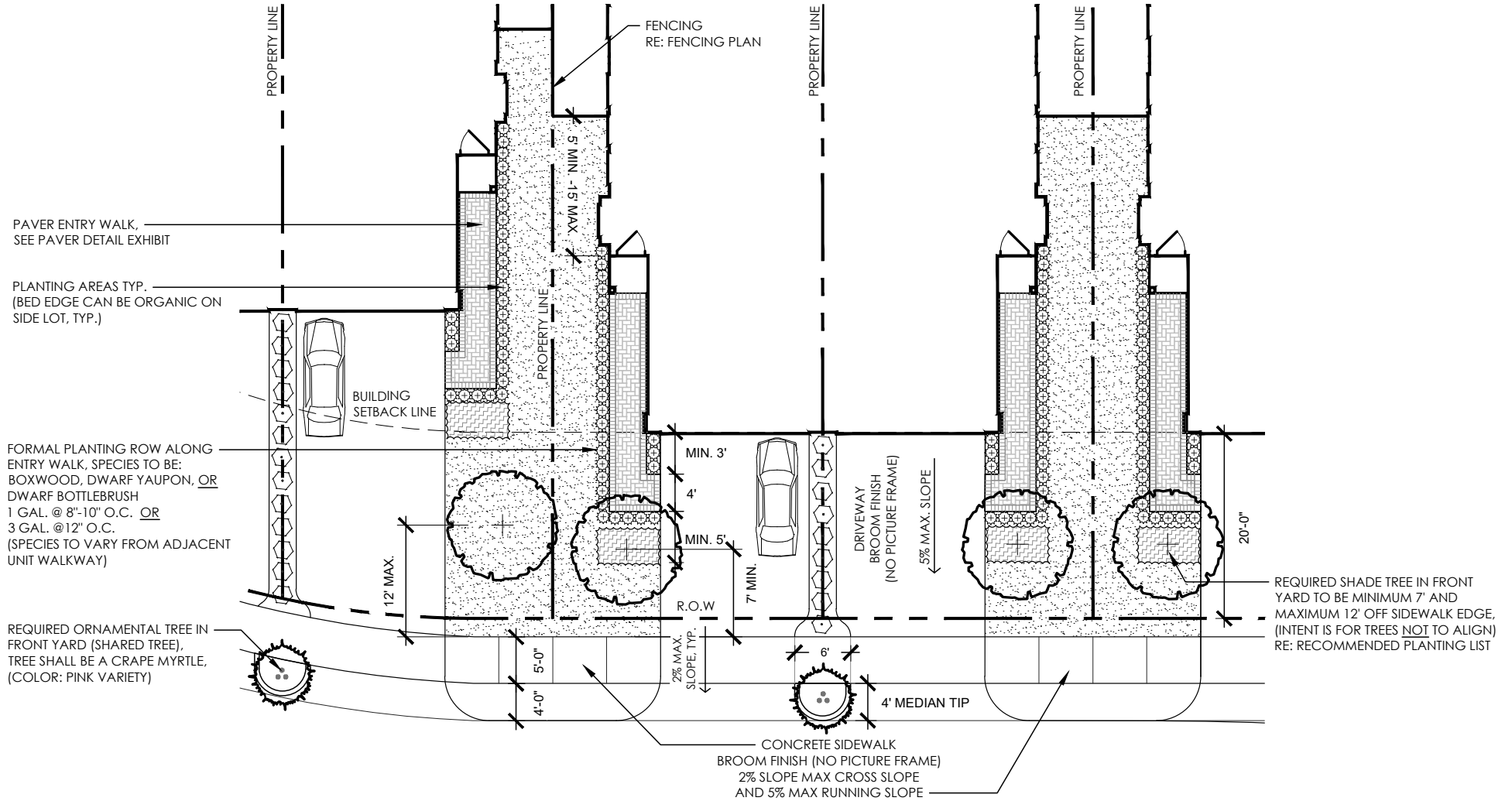

- NOTES:
1. REFERENCE PARKLAND VILLAGE 'NEW CONSTRUCTION DEVELOPMENT STANDARDS' FOR APPROVED PLANTING LIST.
  2. FOR SIDE YARDS AND CORNER LOTS FACING GREENBELTS OR STREET R.O.W., REFERENCE EXHIBITS E2 & E5 OF THIS SUPPLEMENTAL DOCUMENT.
  3. FRONT YARD TO REQUIRE FULL IRRIGATION.
  4. SOD SHALL BE TIFWAY 419 BERMUDA.
  5. NO COLUMNS, WING WALLS OR DECORATIVE FENCING REQUIRED.
  6. NO STREET TREES REQUIRED.

| LOT REQUIREMENTS: 28'                        |                      |
|--|----------------------|
| ITEM   | QUANTITY / LENGTH    |
| FRONT YARD SHADE TREES                       | 1 (3 1/2" CAL. MIN.) |
| ORNAMENTAL TREE                              | 1 (SHARED)           |
| PLANTER BED COVERAGE                         | 40% MIN.             |
| WING WALLS                                   | NONE                 |
| REAR YARD SHADE TREES                        | 1 (2 1/2" CAL. MIN.) |
| REAR YARD ORNAMENTAL TREES (ON AMENITY LOTS) | NONE                 |

# FENCING LAYOUT - (PARKLAND - SECTION 30)

SCALE: NTS

# PV30-C

## BRIDGELAND PARKLAND VILLAGE - SECTION 30 FENCING LAYOUT

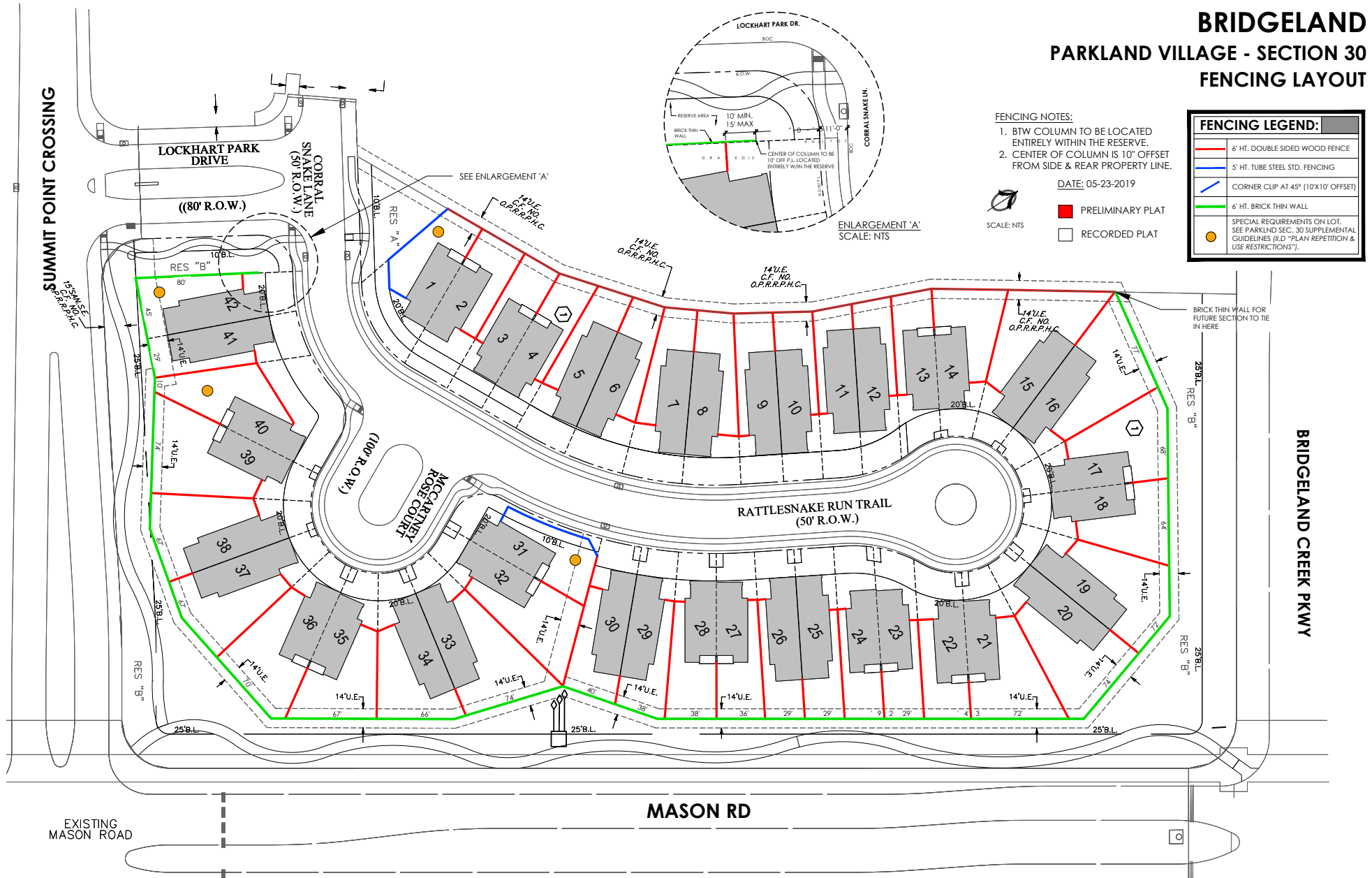

**FENCING NOTES:**

1. BTW COLUMN TO BE LOCATED ENTIRELY WITHIN THE RESERVE.
2. CENTER OF COLUMN IS 10' OFFSET FROM SIDE & REAR PROPERTY LINE.

DATE: 05-23-2019



SCALE: NTS

- PRELIMINARY PLAT
- RECORDED PLAT

| FENCING LEGEND:  |  |
|--|--|
| <span style="display: inline-block; width: 20px; border-bottom: 2px solid red;"></span>  | 6' HT. DOUBLE SIDED WOOD FENCE   |
| <span style="display: inline-block; width: 20px; border-bottom: 2px solid blue;"></span>   | 5' HT. TUBE STEEL STD. FENCING   |
| <span style="display: inline-block; width: 20px; border-bottom: 2px solid green;"></span>  | 6' HT. BRICK THIN WALL   |
| <span style="display: inline-block; width: 0; height: 0; border-left: 5px solid transparent; border-right: 5px solid transparent; border-bottom: 8px solid black;"></span> | CORNER CLIP AT 45° (10'X10' OFFSET)  |
| <span style="display: inline-block; width: 10px; height: 10px; border: 1px solid black; border-radius: 50%;"></span>   | PRELIMINARY PLAT   |
| <span style="display: inline-block; width: 10px; height: 10px; border: 1px solid black;"></span>   | RECORDED PLAT  |
| <span style="display: inline-block; width: 10px; height: 10px; background-color: yellow; border: 1px solid black; border-radius: 50%;"></span>                             | SPECIAL REQUIREMENTS ON LOT. SEE PARKLAND SEC. 30 SUPPLEMENTAL GUIDELINES (I.D. "PLAN REPETITION & USE RESTRICTIONS"). |

**PLAN REPETITION: 28' - (PARKLAND - SECTION 30)**

LOT REQUIREMENTS: 28'

SCALE: NTS

**7011 BUNGALO**  
C, D, E, F, G, H, J

**7051 RETREAT**  
A, B, C, D

**7031 SUMMERHOUSE**  
E, F, G, H

**7061 HAVEN**  
A, B, C, D

**7041 MANOR**  
C, D, E, F

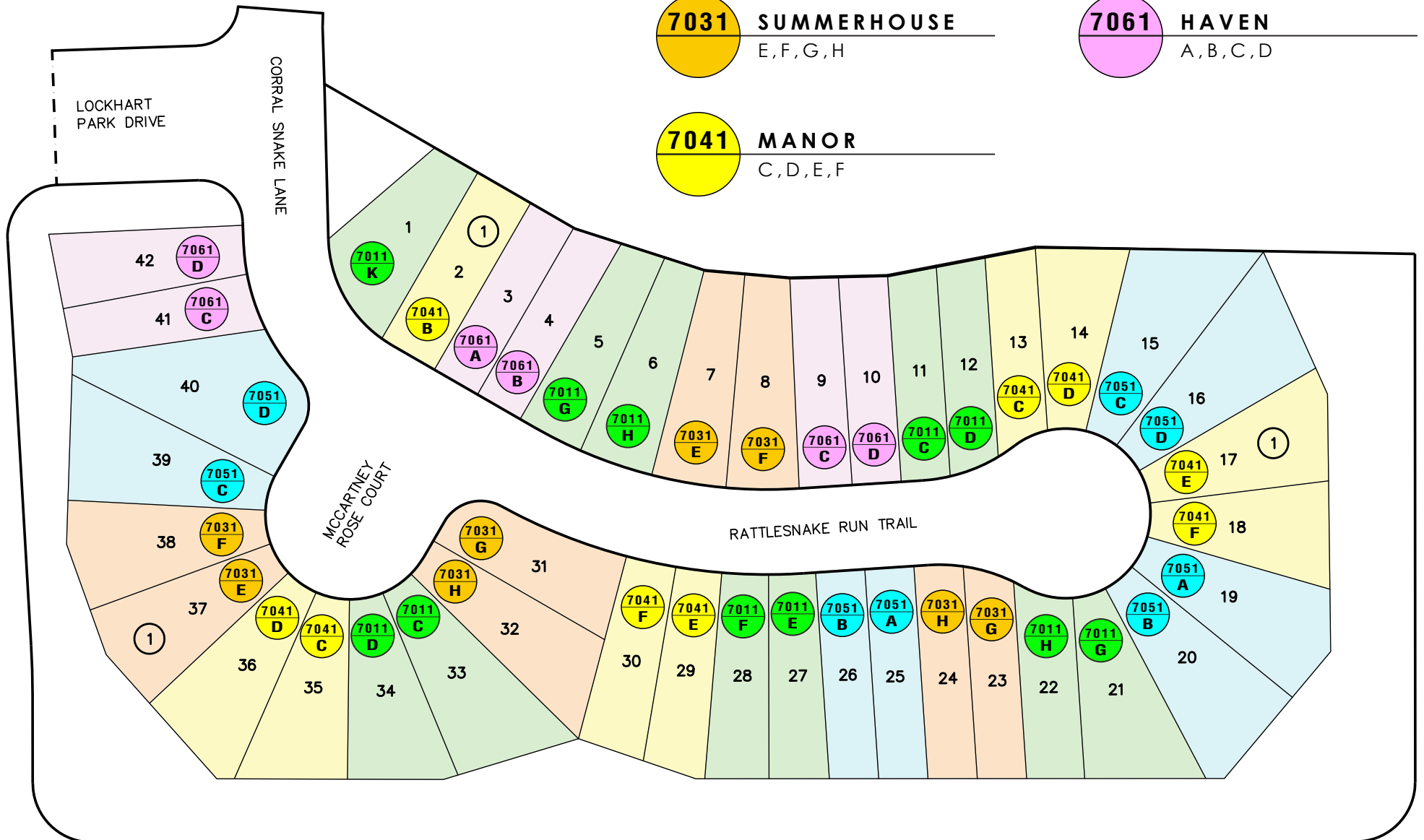

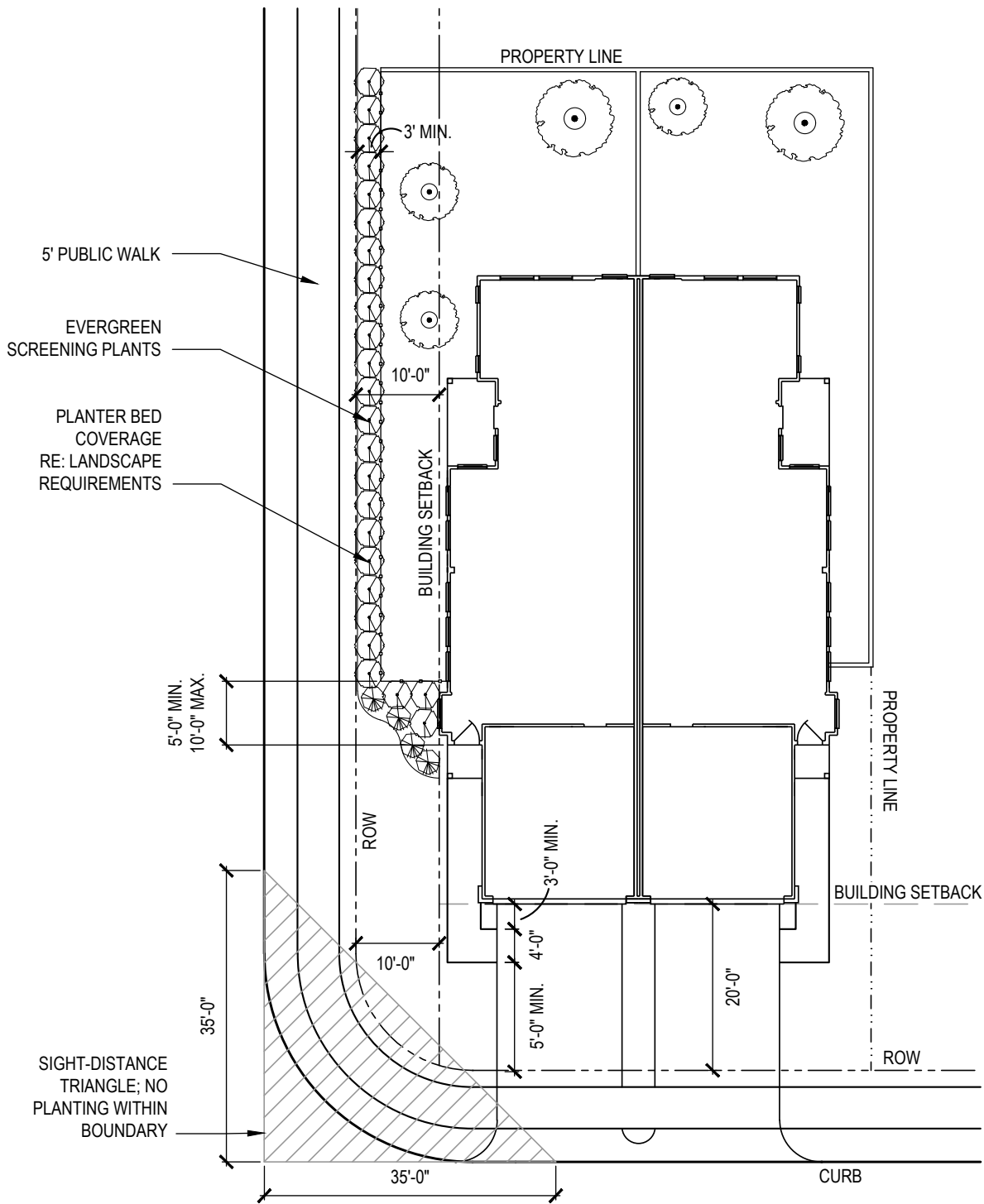

**NOTES**

1. APPROVED EVERGREEN SCREENING PLANTS TO BE INSTALLED IN A SINGLE ROW ALONG FENCE TO CREATE CONTINUOUS SCREEN.
2. REFERENCE LANDSCAPE REQUIREMENTS & APPROVED PLANTING LIST.
3. SOD SHALL BE TIFWAY 419 BURMUDA.
4. PLANTER BED COVERAGE TO REQUIRE 2"-3" OF HARDWOOD MULCH.
5. SHADE TREES IN REAR YARD TO BE 2 1/2" CAL.
6. PLANTING SHALL NOT IMPEDE LOT DRAINAGE.
7. SIDE YARD TO REQUIRE FULL IRRIGATION.
8. PLANTER BED COVERAGE TO CONSIST OF MIN. 50% EVERGREEN PLANTING, 20% ORNAMENTAL GRASS PLANTING & 30% ADDITIONAL PLANTING.

**CORNER LOT REQUIREMENTS**

| ITEM                  | QUANTITY |
|-----------------------|----------|
| SIDE YARD SHADE TREES | 2        |
| REAR YARD SHADE TREES | 1*       |

\* PLANT IN REAR YARD OPPOSITE OF STREET SIDE.

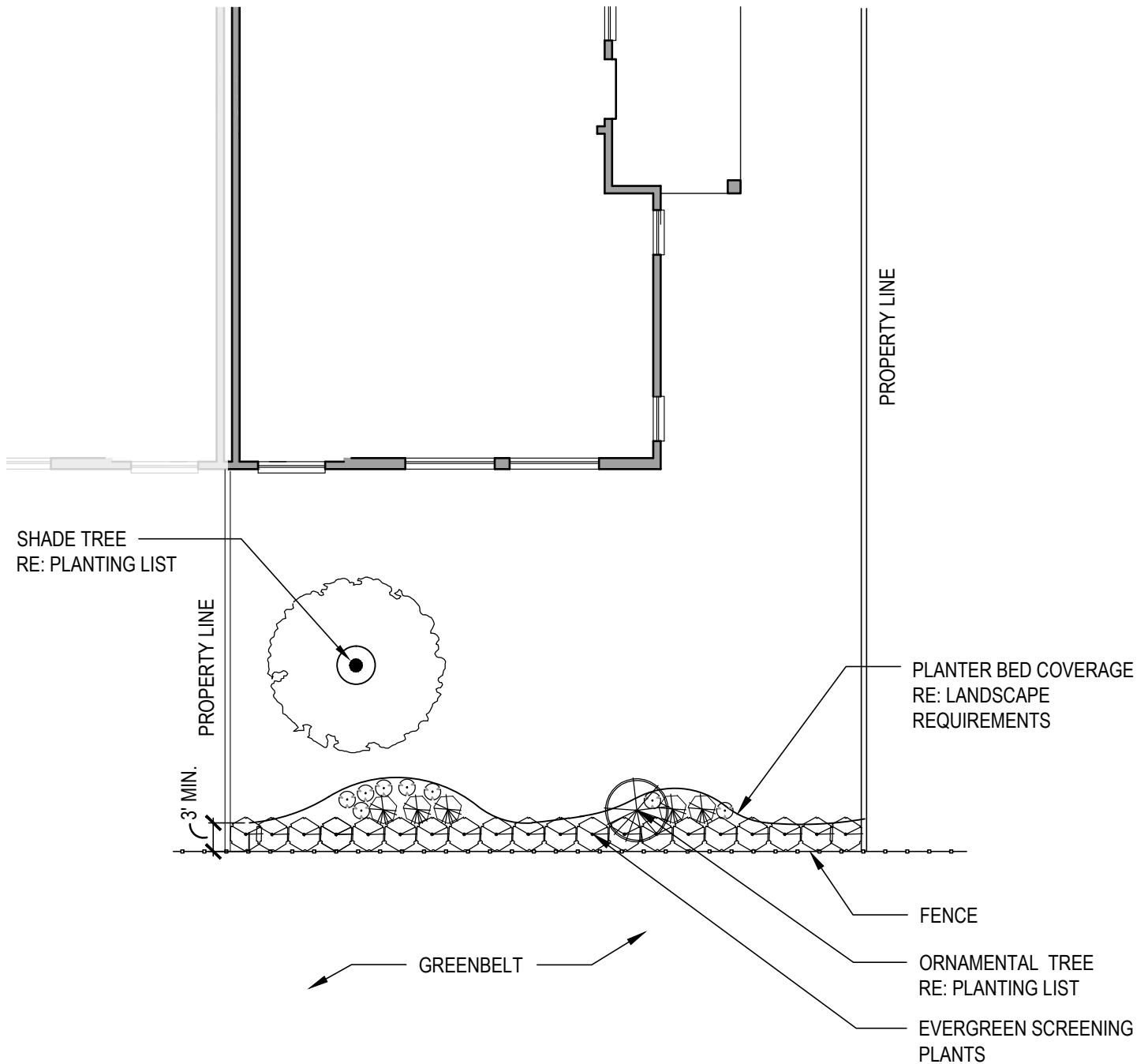

**NOTES**

1. APPROVED EVERGREEN SCREENING PLANTS TO BE INSTALLED IN A SINGLE ROW ALONG FENCE TO CREATE CONTINUOUS SCREEN.
2. REFERENCE LANDSCAPE REQUIREMENTS & APPROVED PLANTING LIST.
3. SOD SHALL BE TIFWAY 419 BURMUDA.
4. PLANTER BED COVERAGE TO REQUIRE 2"-3" OF HARDWOOD MULCH.
5. SHADE TREES IN REAR YARD TO BE 2 1/2" CAL.
6. PLANTING SHALL NOT IMPEDE LOT DRAINAGE.
7. REAR YARD AMENITY LOTS TO REQUIRE FULL IRRIGATION.
8. PLANTER BED COVERAGE TO CONSIST OF MIN. 50% EVERGREEN PLANTING, 20% ORNAMENTAL GRASS PLANTING & 30% ADDITIONAL PLANTING.

| REAR YARD TREE REQUIREMENTS |                 |  |
|-----------------------------|-----------------|--|
| LOT SIZE                    | SHADE TREE QTY. | ORNAMENTAL TREE QTY. (AMENITY LOTS ONLY) |
| 28'                         | 1               | 1  |



# **SUPPLEMENTAL GUIDELINES**

## **SECTION**

# **32**

## DISCLAIMER

Placement of these amended items in the Bridgeland New Construction as well as confirmation of the accuracy and completeness of this document are to be solely determined by Bridgeland Development. All items and requirements not included in this Supplemental Guidelines will defer to the requirements of the Bridgeland New Construction Development Standards for Parkland Village.)

## **Bridgeland – New Construction – Supplemental Guidelines (Parkland - Section 32)**

### **III. ARCHITECTURAL STYLE**

Parkland - Section 32 shall be a transitional modern style of architecture.

#### **A. Materials**

Exterior facade shall be primarily masonry material. Alternate material may be utilized if consistent with the architectural style of the home.

##### **1. Wing Walls**

Wing Walls and/or steps are not required to be used in Parkland - Section 32.

##### **2. Driveways & Private Walkways**

Driveways and private walkways in this section must use decorative pavers or stone consistent with the style of the home as a border for the walk and driveway. The use of these materials is also encouraged and allowed for the walks and driveways in their entirety.

##### **3. Base Wall Material Requirements**

The first level of all homes shall be one-hundred (100%) percent masonry (brick, authentic stucco or stone) on all elevations. Siding on the front elevation will be allowed, on a case-by-case basis, if it is consistent with the architectural style of the home.

##### **4. Second Level/Story Masonry Requirements**

In addition to the Base Wall Material Requirements, the second level of all side and rear elevations of a home which side or rear a street and/or amenity such as, but not limited to, a lake, greenbelt, trail, side street (corner lots) or are otherwise visible to the public, may be siding on, on a case-by-case basis, if it is consistent with the architectural style of the home.

### **IV. PLAN REPETITION**

To meet the streetscape design objectives for the community the following rules apply:

- A.** Production model mix in must avoid monotony, but maintain continuity of scale and character.
- B.** If a plan is to be repeated with the same front elevation design on either the same side or opposite side of the street, it shall not occur more frequently than every third (3rd) consecutive lot. Thus, where this situation exists, at least two (2) other homes shall occur between the next repeated front elevations. Brick and trim color in this situation shall be different.
- C.** If a plan is to be repeated with a different front elevation design on the same side or opposite side of the street, it shall not occur more frequently than every second (2nd) lot. Thus, at least one (1) home shall occur between the next repeated floor plan with a different front elevation design. Brick and trim color shall also be different, with patio homes being an exception.

The ARC reserves the right to reject an elevation that closely resembles that of a nearby house or in any

way detracts from the overall street scene. Identical uses in brick type and color, and siding color are generally prohibited on homes which are adjacent to one another.

## **V. LANDSCAPING**

All Front Yards, Side Yards and Rear Yards are required to be fully landscaped and irrigated. Turf grass shall be Tifway 419 or Celebration Bermuda, but only one can be used in the entire Section.

### **A. Front Yard**

#### **1. Planter Bed(s)**

Landscape planter beds in this section may all be rectilinear in design.

## DISCLAIMER

Placement of these amended items in the Bridgeland New Construction as well as confirmation of the accuracy and completeness of this document are to be solely determined by Bridgeland Development. All items and requirements not included in this Supplemental Guidelines will defer to the requirements of the Bridgeland New Construction Development Standards for Parkland Village.)

## **Bridgeland – New Construction – Supplemental Guidelines (Parkland - Section 37)**

### **I. ARCHITECTURAL STYLE**

Parkland - Section 37 shall be a transitional modern style of architecture.

#### **A. Materials**

Exterior facade shall be primarily masonry material. Alternate material may be utilized if consistent with the architectural style of the home.

##### **1. Wing Walls**

Wing Walls and/or steps are not required to be used in Parkland - Section 37.

##### **2. Driveways & Private Walkways**

Driveways and private walkways in the section must use decorative pavers or stone consistent with the style of the home as a border for the private walkway and driveway. Decorative driveway borders shall be:

- a) A maximum of eighteen (18") inches wide.
- b) Of equal width on both sides of the driveway.
- c) Allowed in addition to the maximum allowed concrete driveway width.

The use of these materials is also encouraged for the private walkways and driveway in their entirety and may be the same maximum driveway width as a concrete driveway with decorative borders as stated above.

##### **3. Base Wall Material Requirements**

The first level of all homes shall be one-hundred (100%) percent masonry (brick, authentic stucco or stone) on all elevations. Siding on the front elevation will be allowed if it is consistent with the architectural style of the home.

##### **4. Second Level/Story Masonry Requirements**

In addition to the Base Wall Material Requirements, the second level of all side and rear elevations of a home which side or rear a street and/or amenity such as, but not limited to, a lake, greenbelt, trail, side street (corner lots) or are otherwise visible to the public, may be siding on if it is consistent with the architectural style of the home.

#### **B. Square Footage**

The allowable livable house square footage is as follows:

##### **1. 40' Lots (40' Lot Product – Darling Homes)**

- 1,400 sqft. (Minimum)

# **SUPPLEMENTAL GUIDELINES**

**PARKLAND**

**37**

## DISCLAIMER

Placement of these amended items in the Bridgeland New Construction as well as confirmation of the accuracy and completeness of this document are to be solely determined by Bridgeland Development. All items and requirements not included in this Supplemental Guidelines will defer to the requirements of the Bridgeland New Construction Development Standards for Parkland Village.)

## Bridgeland – New Construction – Supplemental Guidelines (Parkland - Section 37)

### I. ARCHITECTURAL STYLE

Parkland - Section 37 shall be a transitional modern style of architecture.

#### A. Materials

Exterior facade shall be primarily masonry material. Alternate material may be utilized if consistent with the architectural style of the home.

##### 1. Wing Walls

Wing Walls and/or steps are not required to be used in Parkland - Section 37.

##### 2. Driveways & Private Walkways

Driveways and private walkways in the section must use decorative pavers or stone consistent with the style of the home as a border for the private walkway and driveway. Decorative driveway borders shall be:

a) A maximum of eighteen (18") inches wide.

b) Of equal width on both sides of the driveway.

c) Allowed in addition to the maximum allowed concrete driveway width.

The use of these materials is also encouraged for the private walkways and driveway in their entirety and may be the same maximum driveway width as a concrete driveway with decorative borders as stated above.

##### 3. Base Wall Material Requirements

The first level of all homes shall be one-hundred (100%) percent masonry (brick, authentic stucco or stone) on all elevations. Siding on the front elevation will be allowed if it is consistent with the architectural style of the home.

##### 4. Second Level/Story Masonry Requirements

In addition to the Base Wall Material Requirements, the second level of all side and rear elevations of a home which side or rear a street and/or amenity such as, but not limited to, a lake, greenbelt, trail, side street (corner lots) or are otherwise visible to the public, may be siding on if it is consistent with the architectural style of the home.

#### B. Square Footage

The allowable livable house square footage is as follows:

##### 1. 40' Lots (40' Lot Product – Darling Homes)

- 1,400 sqft. (Minimum)

- 2,500 sqft. (Maximum)

**2. 60' Lots (50' Lot Product – Taylor Morrison)**

- 1,700 sqft. (Minimum)
- 3,400 sqft. (Maximum)

**3. 60' Lots (60' Lot Product – Darling Homes)**

- 2,200 sqft. (Minimum)
- 4,300 sqft. (Maximum)

**II. PLAN REPETITION**

To meet the streetscape design objectives for the community the following rules apply:

- A.** Production model mix in must avoid monotony, but maintain continuity of scale and character.
- B.** If a plan is to be repeated with the same front elevation design on either the same side or opposite side of the street, it shall not occur more frequently than every third (3rd) consecutive lot. Thus, where this situation exists, at least two (2) other homes shall occur between the next repeated front elevations. Brick and trim color in this situation shall be different.
- C.** If a plan is to be repeated with a different front elevation design on the same side or opposite side of the street, it shall not occur more frequently than every second (2nd) lot. Thus, at least one (1) home shall occur between the next repeated floor plan with a different front elevation design. Brick and trim color shall also be different, with patio homes being an exception.

The ARC reserves the right to reject an elevation that closely resembles that of a nearby house or in any way detracts from the overall street scene. Identical uses in brick type and color, and siding color are generally prohibited on homes which are adjacent to one another.

**III. LANDSCAPING**

All Front Yards, Side Yards and Rear Yards are required to be fully landscaped and irrigated. Turf grass shall be Tifway 419 or Celebration Bermuda, but only one can be used in the entire Section. Front Yard landscape planter beds, in this section, may all be rectilinear in design.

# **SUPPLEMENTAL GUIDELINES**

**PARKLAND**

**39**



## DISCLAIMER

Placement of these amended items in the Bridgeland New Construction as well as confirmation of the accuracy and completeness of this document are to be solely determined by Bridgeland Development. All items and requirements not included in these Supplemental Guidelines will defer to the requirements of the Bridgeland New Construction Development Standards for Parkland Village.)

## **Bridgeland – New Construction – Supplemental Guidelines (Parkland - Section 39)**

### **I. ARCHITECTURAL STYLE**

Parkland - Section 39 is a custom home section.

In general, it is not the intent of these standards to dictate specific architectural styles that must be used within the Parkland - Section 39, but rather to give property owners and their architects or designers a set of guidelines that will provide flexibility while achieving continuity and harmony within this section of Bridgeland.

While it is desirable for the homes within Parkland - Section 39 to exhibit the individuality of their owners, designers are encouraged to develop an authenticity to the detailing of the house design based upon the architectural style of the home.

#### **A. Materials**

##### **1. Roofs**

###### **•Á Shingles**

Roof shingles (flat or barreled) shall be clay, slate or concrete on lake lots, but are encouraged to be used on any lot in Section 39. Composite roofs may be used, but are only permitted on non-lake lots. All roof shingles shall be within the architectural style of the home. Roof colors, such as blue, green, red, etc. are prohibited.

###### **•Á Metal**

Standing seam roofs will be approved on a case-by-case basis by the ARC. The use of Galvalume is prohibited.

##### **2. Wing Walls & Steps**

Wing Walls and/or Steps are not required to be used in Parkland - Section 39.

##### **3. Driveways & Private Walkways**

Driveways and private walkways in this section may use decorative pavers or stone consistent with the architectural style of the home.

##### **4. Doors**

Colored front doors shall be consistent with the architectural style of the home. Non-standard colors (non-earth tone) must be submitted for approval prior to installation.

## II. SETBACK

The amended front setback for this Section is:

- Á Twenty (20') feet (Minimum)
- Á Twenty-five (25') feet (Maximum)

### A. Fences

#### 1. Fence Types

Two (2) fence types shall be used in this section:

- Á Five (5') foot tubular steel fencing.
- Á Six (6') foot brick thin wall.

The use of wood fencing is prohibited in this Section.

*(See "PARKLAND FENCING AND DRIVEWAY LAYOUTS" available at [www.KenAnderson.com](http://www.KenAnderson.com) > Residential > Bridgeland.)*

# **SUPPLEMENTAL GUIDELINES**

**PARKLAND**

**42**

**(28' LOTS)**

## DISCLAIMER

Placement of these amended items in the Bridgeland New Construction as well as confirmation of the accuracy and completeness of this document are to be solely determined by Bridgeland Development. All items and requirements not included in this Supplemental Guidelines will defer to the requirements of the Bridgeland New Construction Development Standards for Parkland Village.)

## **Bridgeland – New Construction – Supplemental Guidelines (Parkland - Section 42) – (28’ Lots)**

### **I. GENERAL**

These Supplemental Guidelines are ONLY intended for 28’ Lots (the Twin Villas). All other Lot Widths in Section 42 shall exclusively use the “Parkland – Residential New Construction Development Standards”.

### **II. ARCHITECTURAL STYLE**

Parkland – Section 42 will utilize a traditional style of architecture.

#### **A. Individual Elements & Materials**

##### **1. Masonry**

The front elevation of the all homes shall be primarily masonry (brick, stone, stucco).

Full masonry is not required on the 1st floor unless stated in these Supplemental Guidelines.

*(See section “II. PLAN REPETITION & USE RESTRICTIONS”)*

The use of masonry (brick, stone, stucco) as well as painted brick may be approved within the architectural style of this section on a case-by-case basis as determined by the ARC.

##### **2. Siding**

Where used, the siding, stucco, shingles, board & batten material shall be a cementitious material. These materials shall be of horizontal, lap type, excluding board & batten which shall be vertical.

Siding shall be painted with medium range colors. The use of wood, particle board, or any sheet siding is prohibited. Vinyl or aluminum siding is also prohibited.

##### **3. Wing Wall, Steps & Sidewalks**

No wing walls or steps will be used in Parkland – Section 42.

Front private entry walks shall lead from the front main entry of the home to the driveway and be installed by Builder per the New Construction Development Standards. Front entry walks may not be connected to the public sidewalk or the street curb. Continuous decorative pavers shall be used for the entire surface of the private front entry walks.

*(See attached Exhibit: “PV42-B”)*

##### **4. Driveways**

Driveway locations are set forth by the plan design and lot layout. The ARC may grant variances to site specific situations as it deems appropriate. All driveway designs are subject to review by the ARC. Driveways shall typically cross the building setback area in a straight line at a ninety (90) degree angle to the street right-of-way.

##### **a) Driveway Responsibility/Construction**

Builders are required to build the driveway out to the street. Most lots have a mountable curb at

the street. Driveways are to be a minimum of three and one-half inches (3.5") thick over a sand base. Six by six (6x6) woven wire mesh shall be installed within the apron of the driveway as a minimum. Expansion joints between the curb and driveway are required as illustrated. Where barrier curbs exist, saw cut into existing street and dowel into existing concrete paving. Where the driveways intersect the sidewalk and front walks, the driveway finish may not continue through the sidewalk. The radius at the curb shall be five feet (as necessary to meet sidewalk edge). Sidewalks shall not have a side slope greater than two (2%) percent and a running slope greater than five (5%) percent.

**b) Driveway Widths**

Driveways serving two car garages with a single garage door, facing the street, shall be:

- **Minimum Width:**  
Twelve feet (12')
  
- **Maximum Width:**  
Sixteen feet (16')

**B. Square Footage**

The allowable livable house square footage is as follows:

- 1,600 sqft. (Minimum)
  
- 2,100 sqft. (Maximum)

**C. Fences**

**1. Fence Types**

Three (3) fence types shall be used in this section:

- Five (5') foot tubular steel fencing.
  
- Six (6') foot double sided wood fence – capped.
  
- Six (6') foot Brick Thin Wall (Developer installed fence)

*(See "Fencing and Driveway Layout" available at [www.KenAnderson.com/res-bridgeland](http://www.KenAnderson.com/res-bridgeland))*

**2. Locations**

**a) Front Fences**

Front fences shall be set back a minimum of 5' and a maximum of 15' from the front corner of the entry unless there are conflicts with windows or other architectural elements of the house.

**b) Side Fences (Interior)**

Side fences along interior property lines will be on the property line. Front fences, on the interior side of a corner lot, which are more than ten (10') feet long require a planting buffer.

**c) Side Fence (Street Side – Corner Lot)**

At the street side of corner lots, a minimum side fence setback of three (3') feet from property line.

**III. PLAN REPETITION & USE RESTRICTIONS**

A residential structure plan and elevation repetition should have the following separations:

- A.** In Parkland Section 30 the repetition and locations of plans and elevation has been be determined in advance.

*(See attached Exhibit: "PV42-D")*

- B.** Due to mid-level placement of side elevation windows on plans with split-level entries, masonry on the first floor of side elevations are not visually ideal for lots with higher public visibility. Therefore, plans with split-level entries may not be placed on lots (Lots 16, 25, 26, 45, Block 3; Lots 1, 8, 9, 16, Block 4).

**IV. LANDSCAPING**

**A. Front Yard**

**1. Street Tree(s)**

This section will not include street trees. Instead the required trees have been moved further into the lot.

**2. Shade Tree(s)**

A minimum of one (1) three and a half inch (3.5") caliper shade tree is required in front yards on all lots. Installed a minimum of seven (7') feet and a maximum of twelve (12') feet from the public sidewalk.

**3. Ornamental Tree(s)**

This section will include ornamental trees in the front driveway planter.

*(See attached Exhibit: ""PV42-B")*

**B. Side Yard (Street Side – Corner Lots)**

A continuous evergreen foundation hedge shall run the length of the exterior face of the side fence. Plant material is required to be a minimum of five (5) gallons and 24"-30" inches tall at installation. Approved plants are: Wax Myrtle, Oleander, Elaeagnus, Ligustrum (shrub form) or Burford Holly. Additional shrubs shall be used along the foundation of the home.

*(See attached Exhibit: "PV42-E2")*

**C. Rear Yard (Amenity Lots & Corner Lots)**

Landscape planting and irrigation are required in all Rear Yards.

*(See attached Exhibit: "PV42-E5")*

# LOT REQUIREMENTS: 28' - (PARKLAND - SECTION 42)

SCALE: NTS

# PV42-B

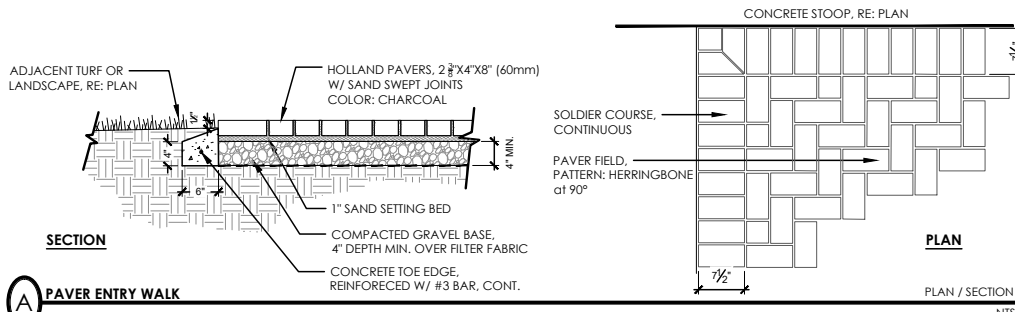
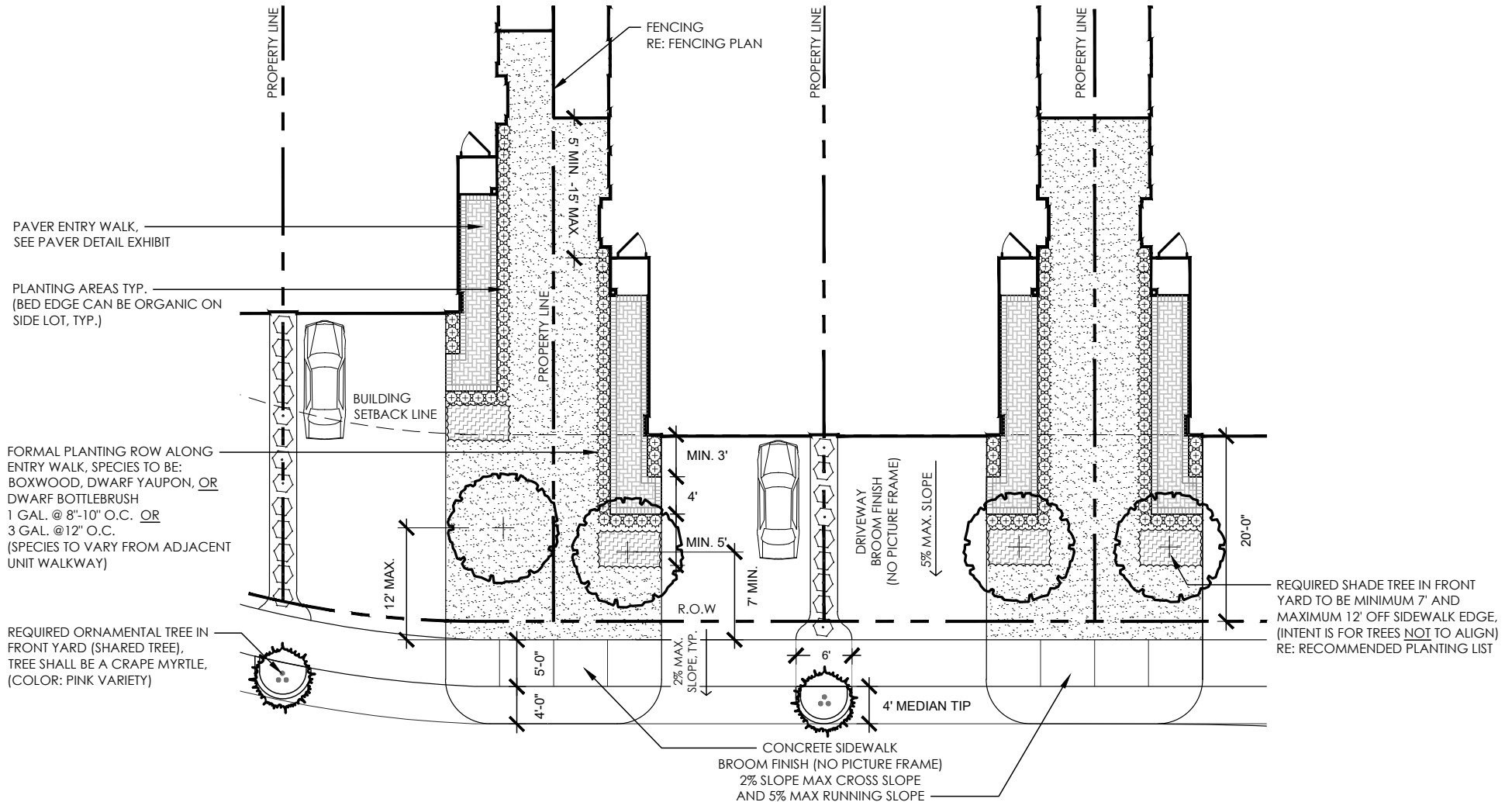

- NOTES:
1. REFERENCE PARKLAND VILLAGE 'NEW CONSTRUCTION DEVELOPMENT STANDARDS' FOR APPROVED PLANTING LIST.
  2. FOR SIDE YARDS AND CORNER LOTS FACING GREENBELTS OR STREET R.O.W., REFERENCE EXHIBITS E2 & E5 OF THIS SUPPLEMENTAL DOCUMENT.
  3. FRONT YARD TO REQUIRE FULL IRRIGATION.
  4. SOD SHALL BE TIFWAY 419 BERMUDA.
  5. NO COLUMNS, WING WALLS OR DECORATIVE FENCING REQUIRED.
  6. NO STREET TREES REQUIRED.

| LOT REQUIREMENTS: 28'                        |                      |
|--|----------------------|
| ITEM   | QUANTITY / LENGTH    |
| FRONT YARD SHADE TREES                       | 1 (3 1/2" CAL. MIN.) |
| ORNAMENTAL TREE                              | 1 (SHARED)           |
| PLANTER BED COVERAGE                         | 40% MIN.             |
| WING WALLS                                   | NONE                 |
| REAR YARD SHADE TREES                        | 1 (2 1/2" CAL. MIN.) |
| REAR YARD ORNAMENTAL TREES (ON AMENITY LOTS) | NONE                 |

# PLAN REPETITION: (PARKLAND - SECTION 42)

LOT REQUIREMENTS: 2020-11-20

SCALE: NTS

# PV42-D

- 7013 BUNGALO**  
N, P, Q, R, T (Model)
- 7033 SUMMERHOUSE**  
L, M, N, P
- 7043 MANOR**  
C, D, J, K, H (Model)
- 7053 RETREAT**  
E, F, G, H
- 7063 HAVEN**  
E, F, G, H

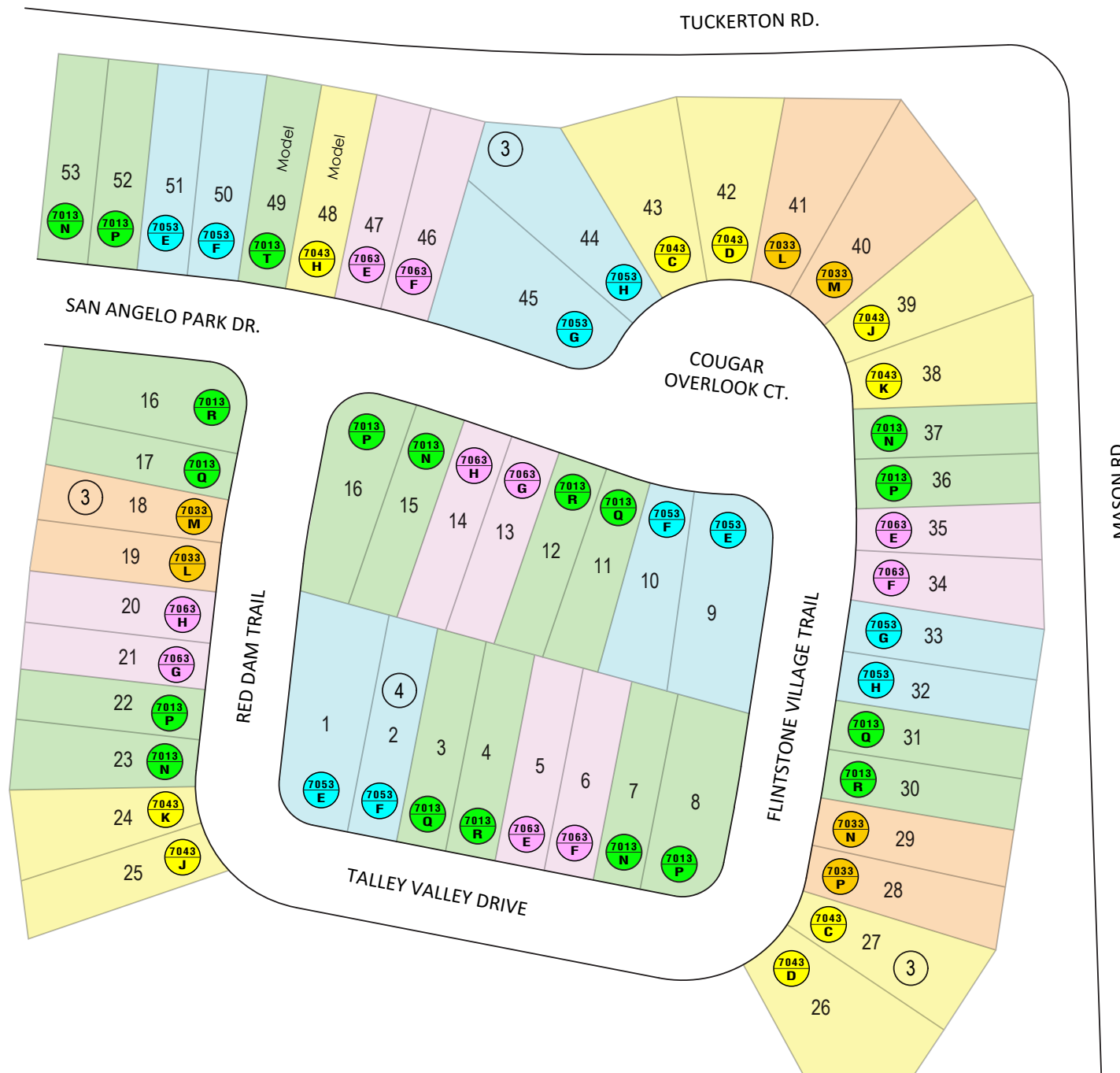



**LANDSCAPE REQUIREMENT: SIDE YARD, CORNER LOT (FRONT LOADED) - TYPICAL**

SCALE: NTS

PV42-E2

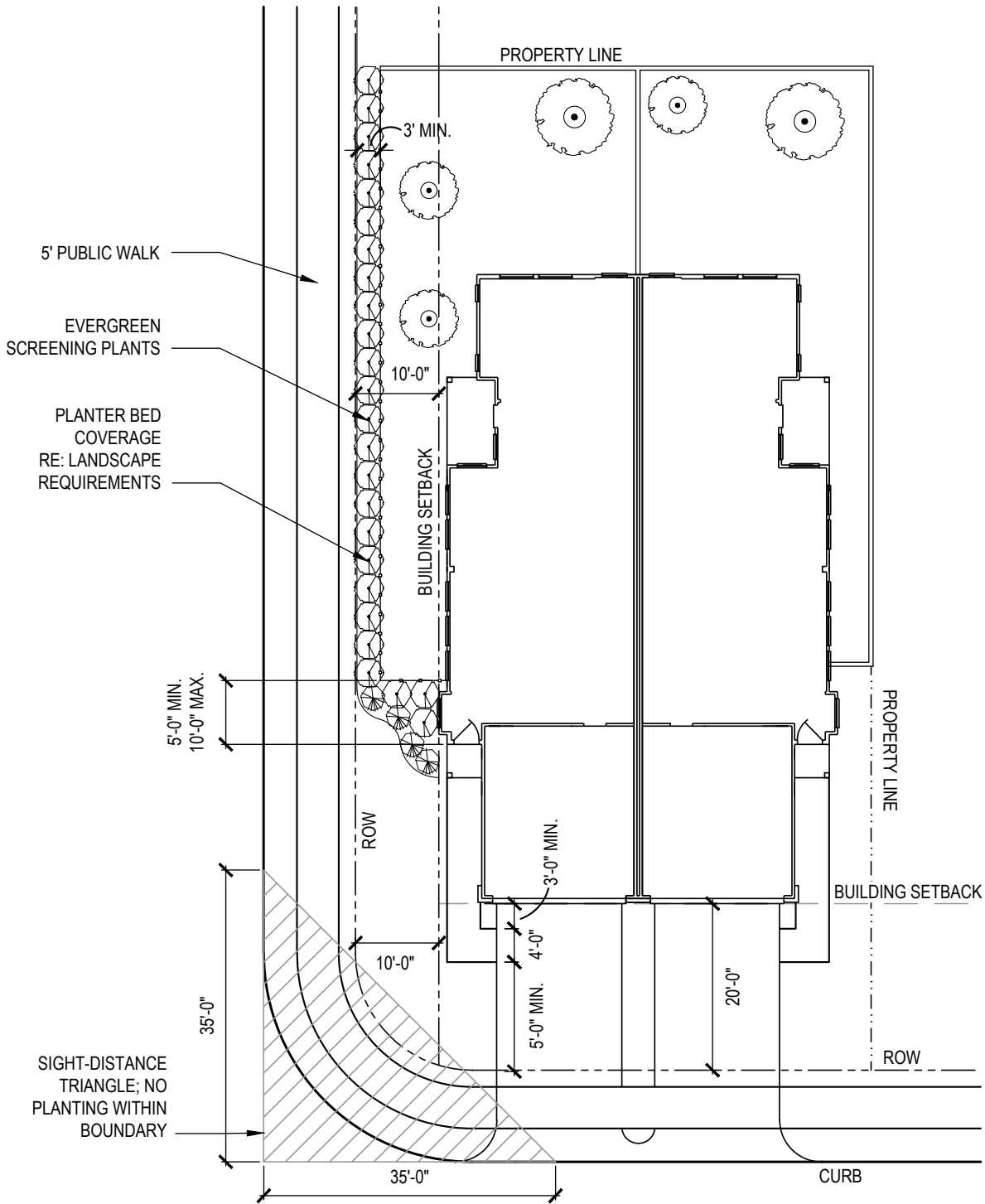

**NOTES**

1. APPROVED EVERGREEN SCREENING PLANTS TO BE INSTALLED IN A SINGLE ROW ALONG FENCE TO CREATE CONTINUOUS SCREEN.
2. REFERENCE LANDSCAPE REQUIREMENTS & APPROVED PLANTING LIST.
3. SOD SHALL BE TIFWAY 419 BURMUDA.
4. PLANTER BED COVERAGE TO REQUIRE 2"-3" OF HARDWOOD MULCH.
5. SHADE TREES IN REAR YARD TO BE 2 1/2" CAL.
6. PLANTING SHALL NOT IMPEDE LOT DRAINAGE.
7. SIDE YARD TO REQUIRE FULL IRRIGATION.
8. PLANTER BED COVERAGE TO CONSIST OF MIN. 50% EVERGREEN PLANTING, 20% ORNAMENTAL GRASS PLANTING & 30% ADDITIONAL PLANTING.

**CORNER LOT REQUIREMENTS**

| ITEM                  | QUANTITY |
|-----------------------|----------|
| SIDE YARD SHADE TREES | 2        |
| REAR YARD SHADE TREES | 1*       |

\* PLANT IN REAR YARD OPPOSITE OF STREET SIDE.

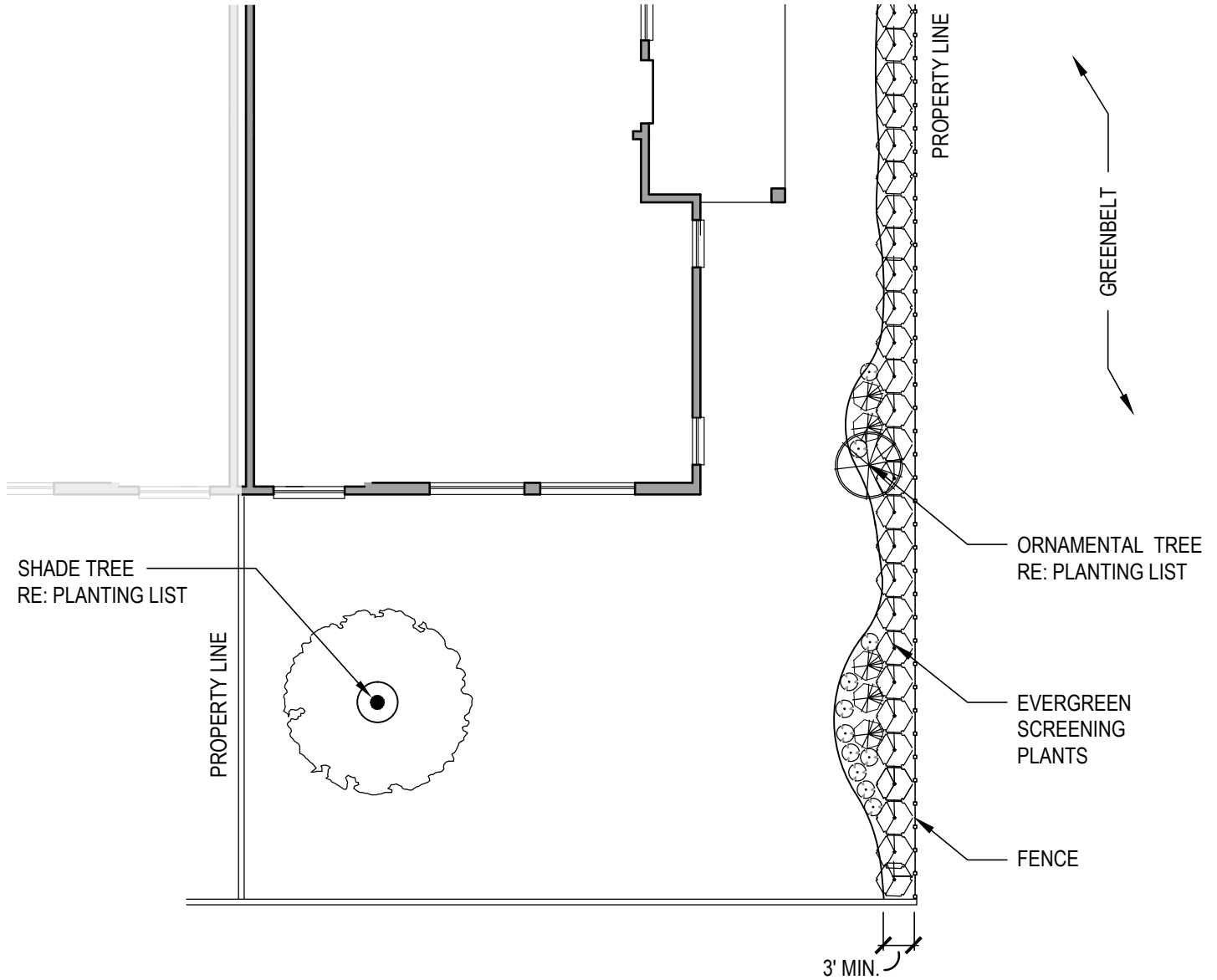

**NOTES**

1. APPROVED EVERGREEN SCREENING PLANTS TO BE INSTALLED IN A SINGLE ROW ALONG FENCE TO CREATE CONTINUOUS SCREEN.
2. REFERENCE LANDSCAPE REQUIREMENTS & APPROVED PLANTING LIST.
3. SOD SHALL BE TIFWAY 419 BURMUDA.
4. PLANTER BED COVERAGE TO REQUIRE 2"-3" OF HARDWOOD MULCH.
5. SHADE TREES IN REAR YARD TO BE 2 1/2" CAL.
6. PLANTING SHALL NOT IMPEDE LOT DRAINAGE.
7. REAR YARD AMENITY LOTS TO REQUIRE FULL IRRIGATION.
8. PLANTER BED COVERAGE TO CONSIST OF MIN. 50% EVERGREEN PLANTING, 20% ORNAMENTAL GRASS PLANTING & 30% ADDITIONAL PLANTING.

| REAR YARD TREE REQUIREMENTS |                 |  |
|-----------------------------|-----------------|--|
| LOT SIZE                    | SHADE TREE QTY. | ORNAMENTAL TREE QTY. (AMENITY LOTS ONLY) |
| 28'                         | 1               | 1  |

# **SUPPLEMENTAL GUIDELINES**

**PARKLAND**

**48**

**Q90' LOTSD**

## DISCLAIMER

Placement of these amended items in the Bridgeland New Construction as well as confirmation of the accuracy and completeness of this document are to be solely determined by Bridgeland Development. All items and requirements not included in these Supplemental Guidelines will defer to the requirements of the Bridgeland New Construction Development Standards for Parkland Village.)

## **Bridgeland – New Construction – Supplemental Guidelines (Parkland - Section 48) - (90' Lots)**

### **I. ARCHITECTURAL STYLE**

Parkland - Section 48 is a custom home section.

In general, it is not the intent of these standards to dictate specific architectural styles that must be used within the Parkland - Section 48, but rather to give property owners and their architects or designers a set of guidelines that will provide flexibility while achieving continuity and harmony within this section of Bridgeland.

While it is desirable for the homes within Parkland - Section 48 to exhibit the individuality of their owners, designers are encouraged to develop an authenticity to the detailing of the house design based upon the architectural style of the home.

#### **A. Materials**

##### **1. Roofs**

###### **•Á Shingles**

Roof shingles (flat or barreled) clay, slate or concrete are encouraged. However, composite roofs may be used on any lot in Section 48. All roof shingles shall be within the architectural style of the home. Roof colors, such as blue, green, red, etc. are prohibited.

###### **•Á Metal**

Standing seam roofs will be approved on a case-by-case basis by the ARC. The use of Galvalume is prohibited.

##### **2. Wing Walls & Steps**

Wing Walls and/or Steps are not required to be used in Parkland - Section 48.

##### **3. Driveways & Private Walkways**

Driveways and private walkways in this section may use decorative pavers or stone consistent with the architectural style of the home.

##### **4. Doors**

Colored front doors shall be consistent with the architectural style of the home. Non-standard colors (non-earth tone) must be submitted for approval prior to installation.

### **II. SETBACK**

The amended front setback for this Section is:

- Á Twenty (20') feet (Minimum)

- Á Twenty-five (25') feet (Maximum)

## **A. Fences**

### **1. Fence Types**

Two (2) fence types shall be used in this section:

- Á Five (5') foot tubular steel fencing.
- Á Six (6') foot brick thin wall.

The use of wood fencing is prohibited in this Section.

*(See "PARKLAND FENCING AND DRIVEWAY LAYOUTS" available at [www.KenAnderson.com](http://www.KenAnderson.com) > Residential > Bridgeland.)*

# **SUPPLEMENTAL GUIDELINES**

**PARKLAND**

**48**

**Q 10' LOTSD**

DISCLAIMER

Placement of these amended items in the Bridgeland New Construction as well as confirmation of the accuracy and completeness of this document are to be solely determined by Bridgeland Development. All items and requirements not included in these Supplemental Guidelines will defer to the requirements of the Bridgeland New Construction Development Standards for Parkland Village.)

**Bridgeland – New Construction – Supplemental Guidelines (Parkland - Section 48) – (110’ Lots)**

**III. ARCHITECTURAL STYLE**

Parkland - Section 48 is a custom home section.

In general, it is not the intent of these standards to dictate specific architectural styles that must be used within the Parkland - Section 48, but rather to give property owners and their architects or designers a set of guidelines that will provide flexibility while achieving continuity and harmony within this section of Bridgeland.

While it is desirable for the homes within Parkland - Section 48 to exhibit the individuality of their owners, designers are encouraged to develop an authenticity to the detailing of the house design based upon the architectural style of the home.

**A. Materials**

**1. Roofs**

• **Shingles**

Roof shingles (flat or barreled) shall be clay, slate or concrete on lake lots, but are encouraged to be used on any lot in Section 48. Composite roofs may be used, but are only permitted on non-lake lots. All roof shingles shall be within the architectural style of the home. Roof colors, such as blue, green, red, etc. are prohibited.

• **Metal**

Standing seam roofs will be approved on a case-by-case basis by the ARC. The use of Galvalume is prohibited.

**2. Wing Walls & Steps**

Wing Walls and/or Steps are not required to be used in Parkland - Section 48.

**3. Driveways & Private Walkways**

Driveways and private walkways in this section may use decorative pavers or stone consistent with the architectural style of the home.

**4. Doors**

Colored front doors shall be consistent with the architectural style of the home. Non-standard colors (non-earth tone) must be submitted for approval prior to installation.

**IV. SETBACK**

The amended front setback for this Section is:

- Twenty (20') feet (Minimum)

- Á Twenty-five (25') feet (Maximum)

## **A. Fences**

### **1. Fence Types**

Two (2) fence types shall be used in this section:

- Á Five (5') foot tubular steel fencing.
- Á Six (6') foot brick thin wall.

The use of wood fencing is prohibited in this Section.

*(See "PARKLAND FENCING AND DRIVEWAY LAYOUTS" available at [www.KenAnderson.com](http://www.KenAnderson.com) > Residential > Bridgeland.)*



# **SUPPLEMENTAL GUIDELINES**

**PARKLAND**

**50**

DISCLAIMER

Placement of these amended items in the Bridgeland New Construction as well as confirmation of the accuracy and completeness of this document are to be solely determined by Bridgeland Development. All items and requirements not included in this Supplemental Guidelines will defer to the requirements of the Bridgeland New Construction Development Standards for Parkland Village.)

## **Bridgeland – New Construction – Supplemental Guidelines (Parkland - Section 50)**

### **I. ARCHITECTURAL STYLE**

Parkland - Section 50 shall be a transitional modern style of architecture.

#### **A. Materials**

Exterior facade shall be primarily masonry material. Alternate material may be utilized if consistent with the architectural style of the home.

##### **1. Wing Walls**

Wing Walls and/or steps are not required to be used in Parkland - Section 50.

##### **2. Driveways & Private Walkways**

Driveways and private walkways in the section must use decorative pavers or stone consistent with the style of the home as a border for the private walkway and driveway. Decorative driveway borders shall be:

a) A maximum of eighteen (18") inches wide.

b) Of equal width on both sides of the driveway.

c) Allowed in addition to the maximum allowed concrete driveway width.

The use of these materials is also encouraged for the private walkways and driveway in their entirety and may be the same maximum driveway width as a concrete driveway with decorative borders as stated above.

##### **3. Base Wall Material Requirements**

The first level of all homes shall be one-hundred (100%) percent masonry (brick, authentic stucco or stone) on all elevations. Siding on the front elevation will be allowed if it is consistent with the architectural style of the home.

##### **4. Second Level/Story Masonry Requirements**

In addition to the Base Wall Material Requirements, the second level of all side and rear elevations of a home which side or rear a street and/or amenity such as, but not limited to, a lake, greenbelt, trail, side street (corner lots) or are otherwise visible to the public, may be siding on if it is consistent with the architectural style of the home.

#### **B. Square Footage**

The allowable livable house square footage is as follows:

##### **1. 40' Lots (40' Lot Product – Darling Homes)**

- 1,400 sqft. (Minimum)

- Á 2,500 sqft. (Maximum)

**2. 60' Lots (50' Lot Product – Taylor Morrison)**

- Á 1,700 sqft. (Minimum)

- Á 3,400 sqft. (Maximum)

**3. 60' Lots (60' Lot Product – Darling Homes)**

- Á 2,200 sqft. (Minimum)

- Á 4,300 sqft. (Maximum)

**II. PLAN REPETITION**

To meet the streetscape design objectives for the community the following rules apply:

- A.** Production model mix in must avoid monotony, but maintain continuity of scale and character.
- B.** If a plan is to be repeated with the same front elevation design on either the same side or opposite side of the street, it shall not occur more frequently than every third (3rd) consecutive lot. Thus, where this situation exists, at least two (2) other homes shall occur between the next repeated front elevations. Brick and trim color in this situation shall be different.
- C.** If a plan is to be repeated with a different front elevation design on the same side or opposite side of the street, it shall not occur more frequently than every second (2nd) lot. Thus, at least one (1) home shall occur between the next repeated floor plan with a different front elevation design. Brick and trim color shall also be different, with patio homes being an exception.

The ARC reserves the right\to reject an elevation that closely resembles that of a nearby house or in any way detracts from the overall street scene. Identical uses in brick type and color, and siding color are generally prohibited on homes which are adjacent to one another.

**III. LANDSCAPING**

All Front Yards, Side Yards and Rear Yards are required to be fully landscaped and irrigated. Turf grass shall be Tifway 419 or Celebration Bermuda, but only one can be used in the entire Section. Front Yard landscape planter beds, in this section, may all be rectilinear in design.

them to shine onto and/or be a nuisance to neighboring properties.

- b. Exterior lights located on the second (2nd) story of the home are prohibited (i.e. Flood lights). Flood lights are permitted only on the rear of the home and are to be located no higher than the first (1st) floor plate height. Additionally, flood lights are prohibited on the side elevations of the home and/or in the side yards.

**c. Soffit/Eve-Mounted Accent Lights**

**i. General**

Lights may not be mounted in a way or installed in locations which will allow them to shine onto or be a nuisance to neighboring properties.

**ii. Front Elevation**

Recessed soffit/eve-mounted accent lights may be used on the first (1st) story and second (2nd) story of the front elevation.

**iii. Side & Rear Elevation**

Recessed soffit/eve-mounted accent lights may only be used on the first (1st) story of side or rear elevations which do not face an adjacent residential lot. (i.e. A side elevation which faces either a side street on Corner Lots or faces an Amenity is authorized. A rear elevation which faces an Amenity is authorized.)

**iv. If used, soffit/eve-mounted accent lights:**

1. Must be fully recessed (the bulb and/or lens may not extend out of the can).
2. Lights must be angled straight down.
3. Lights may not exceed forty (40) watts or equivalent output.
4. One (1) light temperature must be used for all lights, which must be between 2700K and 3000K to produce soft warm white illumination.
5. Lights must be static. Lights which flash or pulse are strictly prohibited.
6. Soffit/eve-mounted accent light cans and trim must match the color of the soffit/eve to which it is installed.
7. Lights may not be mounted in a way or installed in locations which will allow them to shine onto and/or be a nuisance to neighboring properties.

- d. Exterior illumination of architectural features such as private walkway accent walls, entries, chimneys and landscape features is encouraged. A sconce light is preferred. Ground lighting or decorative fixtures shall be of high-quality materials and workmanship and be in scale and style with the residence.

- e. All exterior lighting, including LED lights must be of soft, warm white lighting.

- f. Sodium vapor lights, except for subdivision street lights, are prohibited.

line of the house. Where the rear has several planes, the ARC will make an individual judgment. Decks and patios may be placed within the utility easement; however, the utility company has a right to remove them at the Builder's/ Homeowner's sole expense.

Acceptable materials for decks and patios are to be at the discretion of the ARC.

Suggested materials are:

- Concrete
- Paver
- Wood Trex© or comparable

## 2.6 Setbacks

Front setbacks for houses are shown on the plat and are restated in the exhibits that are part of this document. Side and rear yard minimum setbacks may be shown on the plats, and in the chart below.

| ELEMENT                        | SETBACK       | INTERIOR LOTS | CORNER LOTS   |
|--------------------------------|---------------|---------------|---------------|
| House                          | Front         | 20'           | 20'           |
| House (Patio - Sec 9 & 10)     | Front         | 10'           | 10'           |
| House                          | Interior Side | 5'            | 5'            |
| House                          | Street Side   | N/A           | 10'           |
| House (Patio - Sec 9 & 10)     | Zero Side     | 0'            | N/A           |
| House (Patio - Sec 9 & 10)     | Non-Zero Side | 10'           | 10'           |
| House (1 Story)                | Rear          | 10'           | 10'           |
| House (2 Story)                | Rear          | 20'           | 20'           |
| Garage (Attached)              | Front         | 20'           | 20'           |
| Garage (Detached)              | Rear          | (7.5' or UE)* | (7.5' or UE)* |
| Garage (Detached/Side Loading) | Side          | 3'            | 15'           |
| Driveway                       | Interior Side | 4'            | N/A           |
| Porches                        | Rear & Side   | 5'            | 5'            |
| Decks                          | Rear & Side   | 5'            | 5'            |
| Patios                         | Rear & Side   | 5'            | 5'            |
| Pool Deck                      | Rear          | 5'            | 5'            |
| Pool Deck                      | Side          | 5'            | 15'           |

\* Whichever is greater

## 2.7 Columns, Wing Walls, Cheek Walls & Steps

In keeping with the theme of Bridgeland to create a traditional neighborhood character all lots, unless otherwise stated within these Standards, will incorporate front yard private walkway columns, wing walls, cheek walls and steps. Some lots will be raised with the inclusion of front yard wing walls. These walls and columns will be consistent in height for each lot type. The layout and grading of the wall is described in the following sections. Each lot type has separate requirements for the private walkway columns, wing walls, cheek walls and steps layout. Plant material shall be used to enrich the effect.

All masonry/brick materials used for steps, side walls, wing walls and columns shall be the same materials used

for the house and will need to be in the same sequence/stacking order as the house. Typically, a brick cap with brick or stone on the bottom. No cast stone will be permitted.

*(Reference Exhibits: "A1 - A6")*

Pie-shaped lots with narrow fronts may be eligible for alternate requirements. *(See 2.8 Private Walkways)*

**A. Lots: 50' or Less**

Lots fifty (50') feet wide or less shall not have wing walls. These lots will instead use only:

- Á Columns installed thirteen (13') feet (on center) back from the public sidewalk to negotiate the grade change.
- Á Cheek walls will be installed forward of the columns.
- Á Brick steps shall be installed from the back of the private walkway columns forward.

*(Reference Exhibit: "B1")*

**Note: The following Patio Section(s) will have separate requirements as noted below:**

**Section 9 – Patio**

- Á Columns & wing walls are not required.
- Á No steps are required as part of the private walkway.
- Á Private walkway is required to connect to the street.

**B. Lots: 55' & 65'**

Lots fifty-five (55') feet and sixty-five (65') feet wide shall have:

- Á Columns (with off-set wing walls) installed thirteen (13') feet (on center) from the back of the public sidewalk to negotiate the grade change.
- Á Cheek walls will be installed forward of the columns.
- Á Wing walls will be six (6') feet in length.
- Á Brick steps shall be installed from the back of the private walkway columns forward.

*(Reference Exhibit: "B2")*

**Note: The following Patio Section(s) will have separate requirements as noted below:**

**Section 10 – Patio**

- Á Columns & wing walls are not required.
- Á No steps are required as part of the private walkway.

•Á Private walkway is required to connect to the street.

**C. Lots: 70' & 80'**

Lots seventy (70') feet and eighty (80') feet wide shall have:

- Á Columns (with off-set wing walls) installed thirteen (13') feet (on center) from the back of the public sidewalk to negotiate the grade change.
- Á Cheek walls will be installed forward of the columns.
- Á Wing walls will be ten (10') feet in length.
- Á Brick steps shall be installed from the back of the private walkway columns forward.

*(Reference Exhibit: "B3")*

**D. Lots: 100' or Greater**

Lots one-hundred (100') feet wide or greater shall have:

- Á Columns (with off-set wing walls) installed thirteen (13') feet (on center) from the back of the public sidewalk to negotiate the grade change.
- Á Cheek walls will be installed forward of the columns.
- Á Wing walls will be twelve (12') feet in length.
- Á Brick steps shall be installed from the back of the private walkway columns forward.

*(Reference Exhibit: "B4")*

**E. Lots: Cul-de-Sac**

Lots on Cul-de-Sacs shall have:

- Á Columns installed, nine (9') feet minimum and eleven (11') feet maximum (on center), back from the public sidewalk to negotiate the grade change.
- Á Cheek walls will be installed forward of the columns.
- Á Wing walls will vary in length depending on lot width.
- Á Brick steps shall be installed from the back of the private walkway columns forward.

*(Reference Exhibit: "B5")*

**2.8 Private Walkways**

A five (5') foot private walkway is required to extend from the front door to the terrace steps and extend to the curb. Private walkways that are curvilinear are preferred. The private walkway shall have a brick border excluding the landing between the public sidewalk and the back of curb.

In some cases, the front width of a lot may be too narrow to adequately accommodate a private walkway to the curb (generally on "pie-shaped" cul-de-sac lots). In these cases, the five (5') foot private walkway shall

### III. ARCHITECTURAL DESIGN

#### 3.1 Philosophy-the “Big Ideas”

The standards in this section provide a basis for developing the design concepts, forms, and materials used for homes within Bridgeland. This section identifies those architectural elements that influence the overall neighborhood appearance and perception of the street scene character. These include the appropriateness of a house design to a particular site, overall building massing, the location and visual impact of key elements like entries, garages, etc., the style of the architecture and how it relates to those around it, and the quality and quantity of the exterior materials used on the home.

#### 3.2 Overall Massing

The house shall be sited on the lot so the house and entry are predominant and the garage minimized.

##### A. Height

Varied elevations and arrangements on the site are encouraged to create a more interesting street scene. More pleasing arrangements are achieved with a variety of articulated plans, which break the rectangular box into interesting three-dimensional shapes with courtyard-like spaces in and around each house. In addition to the improved footprints, the street scene is made more attractive with the combination of right and left-hand units if garages are not detached.

#### 3.3 Individual Elements

##### A. Entries

The main entry shall provide an important point of interest to each home and shall be protected with overhangs, recesses, porches, or trellises. Sidelights and transoms are encouraged. When used with wall extensions, the whole entry can even result in a courtyard effect.

##### B. Garages

Each house shall have a garage capable of accommodating a minimum of two (2) full size automobiles and a maximum of four (4).

Two (2) car garages may use a single sixteen (16') foot wide door or two (2) single eight (8') foot or nine (9') foot wide garage doors.

Three (3) garage bays may front the street provided both of the following requirements are met:

1. That the third bay is set back a minimum of twelve (12") inches from the other two bays.

2. Two (2) bay garages must use a single sixteen (16') foot wide door.

3. A single eight (8') foot or nine (9') foot wide garage door may only be used for the third bay.

4. The lot can accommodate the configuration without any encroachments.

Additionally, a separate roofline over the third bay is preferred to break up the view from the street. Detached three car garages located in the rear yard or side yard on a corner lot will be allowed. An extension in the depth of a garage which permits additional storage space is permitted.

The front façade of front-loaded detached garages shall be the same masonry used on the main house, except at garage door headers, where siding can be used.



shall be no higher than ten (10") inches above the roof surface. Under no circumstances shall any of the above-mentioned items extend above the ridge line or parapet on an approved flat roof. The number and size of stack vents shall be minimized.

#### **D. Chimneys**

- (1) Chimneys can be used to establish an ornamental or thematic character. The minimum plan dimensions for an exposed mass is twenty-four inches by twenty-four inches (24" x 24") and a larger form is preferred.
- (2) In the event of gas fireplaces, direct vents in place of chimneys are allowed, provided roof-mounted vents are located along the rear slope or rear half of the roof and painted to match the shingles. Direct vents located on exterior walls of the home must be painted the same color as the surface material they project out from.
- (3) The height of the chimney shall be in proportion to the roof line and adhere to fire codes. Broad, massive chimneys are encouraged. Small, spindly shaped chimneys will not be approved. Chimneys which barely peak above or squat on the roof are unacceptable.
- (4) Exposed metal flues are not allowed. They may be used only when faced with the brick/ masonry used on the house.
- (5) Fireplaces shall be made of the same material as the house. Exterior chimneys on all lots shall have all sides constructed with brick/ masonry materials, matching the house.
- (6) If a chimney occurs in an interior portion of the roof (not an external house edge) or at the rear or non-corner side of a home, it shall be constructed of materials that match the architectural style and color of the home. Stucco, or wood sided chimneys are permitted in these locations. Cladding metal flues with masonry, brick, or wood is required if metal flues are to be used.
- (7) Spark arrestors and caps are required on all chimneys. The spark arrestor and cap shall be unadorned and designed to match or be compatible with the color and material of the exterior elevations of the home. Caps shall be of metal or masonry construction. Spark arrestors may not exceed the height of the chimney cap. All chimney caps must be painted with a matte finish paint to coincide with the color scheme of the home.
- (8) Heights of chimneys shall meet all fire code requirements and be proportional to the roofline of the respective home.

#### **E. Decks/Patios/Porches**

##### **(1) Porches**

Porches are encouraged; they provide relief to elevations and architecture transition between outdoor and indoors. When a porch makes up at least fifty (50%) percent of the front elevation it, may be considered as the primary front plane of a house for calculating the garage setback.

##### **(2) Deck/Patio Design**

Any exterior deck shall read as an integral element of the house design. Front yard decks and patios will generally not be approved unless necessary to accommodate a unique feature on the lot, and when integrated into the overall entry sequence of the dwelling.

Where a patio is concrete and has an exposed foundation more than one foot in height, the edge shall

## D. Detailed Elements

### (1) Gutters & Downspouts

Gutters and downspouts shall be designed and installed so that water runoff does not adversely affect drainage on adjacent property. If gutters are not used, positive drainage away from the building shall be provided. Downspouts are to be located to provide a clean, unobtrusive appearance, terminated by either splash blocks or connection to the storm sewer. Gutters and downspouts shall be integrated with architectural design in color, shape, and location. All gutters & downspouts shall be painted to match the trim of the home. Downspouts which do not occur on a corner of the home are encouraged to be painted to match the dominant wall color/material for which it is adjacent. Drain pipes tied into rain gutter downspouts shall be completely hidden from view, by shrubs or ground cover large enough and dense enough to screen.

### (2) Rain Gutter Drains

Although gutters are not required, roof design or the use of diverters are encouraged to keep dripping water off of patios, balconies, stairs, doorways, etc. Positive drainage away from the house should be provided for rainfall, irrigation, air conditioner condensate and all other types of water runoff. Roof drainage that will ultimately create erosion or run across pedestrian walks and paths is not acceptable. Drainpipes tied into rain gutter down spouts shall be completely hidden from view. Plant shrubs and ground cover large enough and dense enough to screen visual obstructions. Use splash blocks where practical.

### (3) Screens

Solar screens are prohibited.

### (4) House Numbers

House numbers shall be a minimum of four (4") inches tall sandblasted into a precast panel unless a different medium is more appropriate to the style of architecture (i.e. craftsman, etc.). The panel shall be located on the front façade of the house facing the street for which the address of the home is designated. Particular fonts are not required; however, the text shall be easily read from the street. Logos of any kind are not permitted on address plaques.

### (5) Security Devices/Bars

Security devices such as cameras, sirens and speaker boxes shall be the minimum size needed to be effective and shall be located in the least conspicuous location while allowing satisfactory performance. As previously mentioned under the section for "Entrances and Windows", security and/or burglar bars on the exterior of homes are not permitted. If security devices are being considered for a home, the builder shall utilize a device which is minimally visible to public view and preferably mostly contained within the home. Cameras are to be located under the eaves of the home and the camera(s) or their field(s) of vision shall not be placed to be focused on any neighboring property. All cabling must be concealed.

### (6) Exterior Materials/Colors

The ARC will consider optional materials not included or listed below that are, in the opinion of the ARC equal or greater in quality level. Materials shall be used with restraint in regard to both color and diversity of material types. The intent is to create a continuity of materials and color throughout the neighborhood. The number of primary materials on the exterior will be limited to three (3) not including roof shingles.

**(7) Painting / Colors of Pipes, Vents & Functional Louvered Vents**

All wall extrusions / penetrations, equipment attached to exterior walls or similar, including, but not limited to pipes (PVC, metal, etc.), wall vents, utility meters, etc. must be the same color as the surface material they project out from or to which they are directly attached.

**(8) Base Wall Material Requirements**

The first level of all homes shall be one-hundred (100%) percent masonry (brick, authentic stucco or stone) on all elevations. Siding on the front elevation will only be allowed on minor elements such as, dormers, gables, etc. on a case by case basis.

**(9) Second Level/Story Masonry Requirements**

In addition to the Base Wall Material Requirements, the second level of all side and rear elevations of a home which side or rear a street and/or amenity such as, but not limited to, a lake, greenbelt, trail, side street (corner lots) or are otherwise visible to the public, shall also be one-hundred (100%) percent masonry (brick, authentic stucco or stone) on the entire second level.

**(10) Wall Material Transitions**

All transitions between materials shall occur at logical points in the elevation. Where there is a transition on the upper levels of a home from masonry to another approved material on a side elevation, the masonry shall extend back at least two (2') feet. Exceptions will be considered on a case by case basis. No material change may ever occur on an outside corner.

**(11) Brick**

Brick shall be hard fired and have an overall appearance of relative evenness in color and texture. Only earth tone colors are acceptable. Painted brick shall only be permitted on a case-by-case basis as determined by the ARC and shall be of a matte finish. Brick shall meet standard specifications established by The Brick Institute of America.

**(12) Stone**

If stone is to be incorporated, it shall be earth tones.

**(13) Masonry Mortar Joints**

All mortar joints shall be tooled; "slump" joints will not be allowed. Mortar colors if used, shall be selected to compliment the brick or stone color. Caulking of vertical expansion joints and border joints must match mortar color.

**(14) Siding**

Siding may only be used as a secondary material. Where it is used, the siding, stucco, shingles, board & batten material shall be a cementitious material. These materials shall be of horizontal, lap type, excluding board & batten which shall be vertical.

Siding shall be painted with medium range colors. The use of wood, particle board, or any sheet siding is prohibited. Vinyl or aluminum siding is also prohibited.

**(15) Stucco**

If used, the use of authentic stucco is required on the front elevation. Additionally, if stucco is used on the side and/or rear elevations of homes which side or rear street and/or an amenity such as, but not limited to, a corner lot, lake, greenbelt, trail, or are otherwise visible to the public, authentic stucco must be used on all elevations of the home.

The use of matte-finished stucco board is only permitted on the sides and rear of the home if it does not side or rear a street or an amenity such as, but not limited to, a corner lot, lake, greenbelt, trail, or is otherwise visible to the public. The stucco shall conform in color with all other exterior housing materials.

**(16) Trim**

All trim shall be smooth/ semi-smooth, high quality finish grade stock wood or fiber cement board.

**(17) Windows**

Window type/color/finish shall be complimentary to the overall character of the home's design. Mill finish aluminum is not permitted. Reflective, "mirrored" or tinted glass is not permitted.

**(18) Awnings**

Awnings are prohibited.

**(19) Exterior Colors**

Exterior paints and stains for each residence shall be selected to complement or harmonize with the colors of the other materials with which they are used. The general intent is to encourage greater variety among homes along the street. Wood siding and trim shall generally stay within the earth tone color family. The use of white is also permitted. Extremely bold or primary colors, however, are prohibited. Yellow, blue, or green pastels are discouraged.

However, soft and muted earth tone pastel colors like gray, beige, brown, salmon, etc., are acceptable. The variety and number of exterior colors on each house shall be held to a maximum of three (3) not inclusive of brick color or front door color. Brick colors shall generally be of an earth tone family or range. No one brick color family shall dominate a particular street scene.

Dark colored brick is preferred. Brick for houses on consecutive and facing lots shall vary in order to avoid monotony. Variety in brick use is highly encouraged. Likewise, trim color and/or field color shall also vary.

All exterior paint must be flat or matte finish.

There must be a minimum of at least two (2) lots between (on the same side of the street) and two (2) lots in both directions (from the lot across the street) between homes with the same or similar paint color(s) on the main fields of a home.

In cases where two or more homes are painted the same or similar colors (as determined by the Developer and/or the ARC) within less than the minimum number of lots apart required, the builder/lot whom painted subsequent to the first will be required to repaint their home(s) to a different/non-similar color to any home within the minimum number of lots required, at the builder's sole expense.

Failure to follow these requirements may result in the home being repainted at the builder's sole expense.

**(20) Exterior Building Lighting**

Any lighting on individual lots shall be directed away from adjoining property. Light sources shall not conflict with the sight lines of pedestrians or motorists in a manner which endangers their safety and welfare.

## IV. FENCING

### 4.1 General

This chapter outlines required fencing locations and types.

### 4.2 Fence Responsibility

Neighborhood fencing as outlined and illustrated in these guidelines will be the responsibility of each builder as they develop lots.

### 4.3 Fence Types & Requirements

Both metal and wood fencing will be used. These fence types are detailed below. All wood fence hardware connections are to be screw or ring shank nails, on a straight-line guide. No used material is allowed. Fences are to be kept in good repair. Painting, sealing or staining of fences is prohibited.

#### A. Wood Fence

All wood fences shall be six (6') foot solid, double-sided, capped, trimmed and include a rot board. **No exposed ends will be permitted and the fence end must match the profile of the fence.** Builder must install both sides of fence at the time of initial fence construction. The use of RightWood fence products is not allowed. **The bottom of pickets shall be parallel and flush to the rot board.**

*(Reference Exhibits: "D1 & D2")*

#### B. Metal Fence

All metal fencing will be of a manufactured product that uses pre-galvanized steel with a zinc phosphate primer coating and a topcoat paint finish. All mounting hardware will be of a bracket design. All metal fencing will be of a design that allows it to easily accommodate changes in elevation by use of a rackable system.

All metal fencing will have a flush mount bottom rail. All metal fencing will have a minimum 15-year manufacturer warranty. Tube steel fence shall be provided by Fortress Fence Products **or Ameristar Fences and meet or exceed the specifications of the** V2 FT/FB2 Commercial Fence (flat top, flat bottom) as provided by Fortress Fence Products.

*(Reference Exhibit: "D3")*

#### C. Developer Installed Thinwall

Some lots, generally those backing or siding thoroughfares, collector streets and/or Section boulevard entrances, will have a Developer installed thinwall.

*(Reference "Section Fencing & Driveway Layouts")*

### 4.4 Fence Locations

#### A. Front Fences

Front fences shall be set back, a minimum of ten (10') feet and maximum of fifteen (15') feet, from front corner face of the house unless there are conflicts with windows or other architectural elements of the house.

#### B. Side Fences (Interior)

Side fences along interior property lines will be on the property line. Side interior fences more than ten (10') feet long require a planting buffer.

**J. Angled Fence**

Side or rear fences on corner lots that perpendicular to the lot behind them will be angled at a forty-five (45) degree angle to meet the front building line of the perpendicular lot.

*(Reference Exhibits: "D6 -D7")*

**K. Fences as Screening**

Utility meters, A/C units, pool equipment or other equipment shall be fully screened from public view with fencing and/or landscape. If landscaping is used, it shall create a solid screen immediately when planted.

**(1) Interior Lots**

Buyer must install at least one native shrub at the front of the A/C Unit and or Pool Equipment. The shrub must be at least half the height of the tallest-unit it is screening, and must be full, fast growing, hardy and drought resistant. Vegetation cannot be split/torn into multiple pieces. If a shrub and or other vegetation item are split/torn into pieces to plant in multiple areas, those plants will not be counted towards meeting the landscape requirements and their replacement may be requested at Final Inspection.

**(2) Corner Lots**

Buyer must install at least one native shrub at the front of the A/C Unit and or Pool Equipment. One additional shrub must be installed on the street facing side of each A/C Unit. Pool Equipment, depending on the size of the cluster, may require the installation of additional shrubs to create adequate side screening. All shrubs must be at least half the height of the tallest unit it is screening and must be full, fast growing, hardy and drought resistant.

**L. Other Fence Types**

The ARC will consider other fence types only where there are special conditions exist. Diagonal and horizontal fencing as well as chain link will never be permitted.

**M. Submission and Approval**

The ARC shall approve all fences prior to installation. The Builder shall clearly identify on each site submission, the fence type being proposed on all sides of the lot, as a confirmation of correct interpretation of the information on the Neighborhood Diagrams in the Appendix.

**4.5 Fencing Diagrams**

*(Please see "Section Fencing & Driveway Layouts".)*

**4.6 Gates**

**A. Front Fence Gates**

Gates will be allowed on front fences.

**B. Side Fence Gates**

Gates on side fences are prohibited.

**C. Rear Fence Gates**

Gates on rear fences will be considered on a case-by-case basis and only on lots which back to an amenity.

## VI. Procedures & Submissions

### 6.1 General

The process of submitting plans, specifications and samples to the Bridgeland Architectural Review Committee (“ARC.”) is explained in this section. This process is intended as an instrument for insuring that builders maintain uniform conformance to the guidelines, which have been established to create a new town consistent with the Bridgeland Mission Statement. Within the stated time-period for review, a clear and direct statement as to acceptability of construction plans will be made to builders who make submissions in accordance with the standards.

The builder is solely responsible and liable for following the requirements of these Standards regardless of whether detail(s) of items are noted/called out on reviews/documentation including, but not limited to plans, permits, applications and inspections.

### 6.2 Scope of This Document

All new construction, subsequent construction, remodeling with exterior exposure, expansion, and demolition of structures within Bridgeland shall be reviewed and approved by the ARC, prior to commencement of any on-site building or construction activity. The ARC may consider any and all exterior elements of design including, but not limited to, size, massing, architectural style, colors, materials, harmony of design and other factors that, in the opinion of the ARC, affect the appearance of the improvement(s) and/or their compatibility with surrounding development.

This document specifically applies to the activities of Builders constructing new homes on lots on which there are no existing structures. A separate yet similar document will govern subsequent activities by homeowners or builders on lots once the initial construction activities have been completed.

### 6.3 Procedure

The review process begins when a Builder submits an online application including a set of plans, drawings, specifications and other required information to the ARC for processing. Submissions shall be made using the website below:

www.KenAnderson.com  
Office: 281-367-5430

### 6.4 Required Submission Information

The builder is required to submit the following information to be reviewed by the ARC.

#### A. Architectural

- (1) Floor plans and (all) exterior elevations.
- (2) Outline specifications with materials/colors list clearly referenced to location.
- (3) Statement of House Square Footage. Note that ALL air-conditioned interior space, including, but not limited to, granny flats, shall be measured from interior stud to interior stud and be included in the house square footage.

#### B. Site

Plot plan drawing including the following information:

- (1) Village Name, Neighborhood Name, Section Number, Block Number, Lot Number.

LOT REQUIREMENTS: CUL-DE-SAC

SCALE: NTS

B5

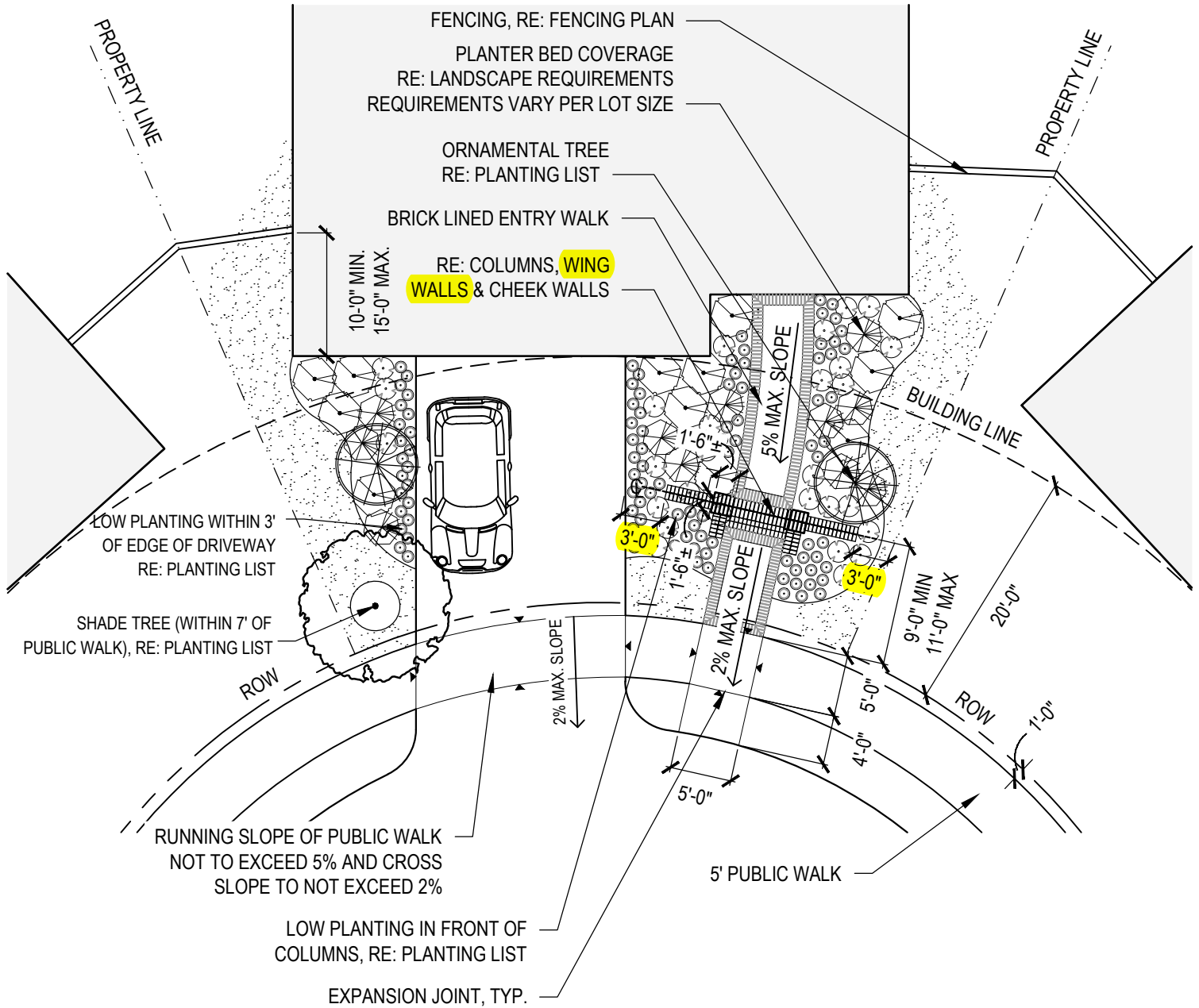

▲ EXPANSION JOINT, TYP.

NOTES

1. REFERENCE LANDSCAPE REQUIREMENTS, APPROVED PLANTING LIST & COLUMNS, WING WALLS & CHEEK WALL STANDARD NOTES.
2. FRONT YARD TO REQUIRE FULL IRRIGATION.
3. SOD SHALL BE TIFWAY 419 BERMUDA.
4. PLANTER BED COVERAGE TO REQUIRE 2"-3" OF HARDWOOD MULCH.
5. SHADE TREES IN REAR YARD TO BE 2 1/2" CAL.
6. PLANTING SHALL NOT IMPEDE LOT DRAINAGE.
7. \*PLANTER BED COVERAGE TO CONSIST OF MIN. 50% EVERGREEN PLANTING, 20% ORNAMENTAL GRASS PLANTING & 30% ADDITIONAL PLANTING.
8. IF REQUIRED LENGTH OF WING WALL FOR LOT WIDTH IS NOT ACHIEVABLE AT REQUIRED SETBACK ON CUL-DE-SAC LOTS, THEN CENTER WALKWAY BETWEEN DRIVEWAY AND SIDE PROPERTY LINE. WING WALL LENGTH SHALL EXTEND FROM COLUMN TO 3' FROM DRIVEWAY & SIDE PROPERTY LINE AND BE THE SAME LENGTH.

| LOT REQUIREMENTS: CUL-DE-SAC                 |                 |
|--|-----------------|
| ITEM   | QUANTITY/LENGTH |
| FRONT YARD SHADE TREES                       | 1               |
| ORNAMENTAL TREE                              | 1               |
| PLANTER BED COVERAGE*                        | 40%             |
| WING WALLS                                   | VARIES          |
| REAR YARD SHADE TREES                        | VARIES          |
| REAR YARD ORNAMENTAL TREES (ON AMENITY LOTS) | VARIES          |



All New Exhibit (8-14-2019)

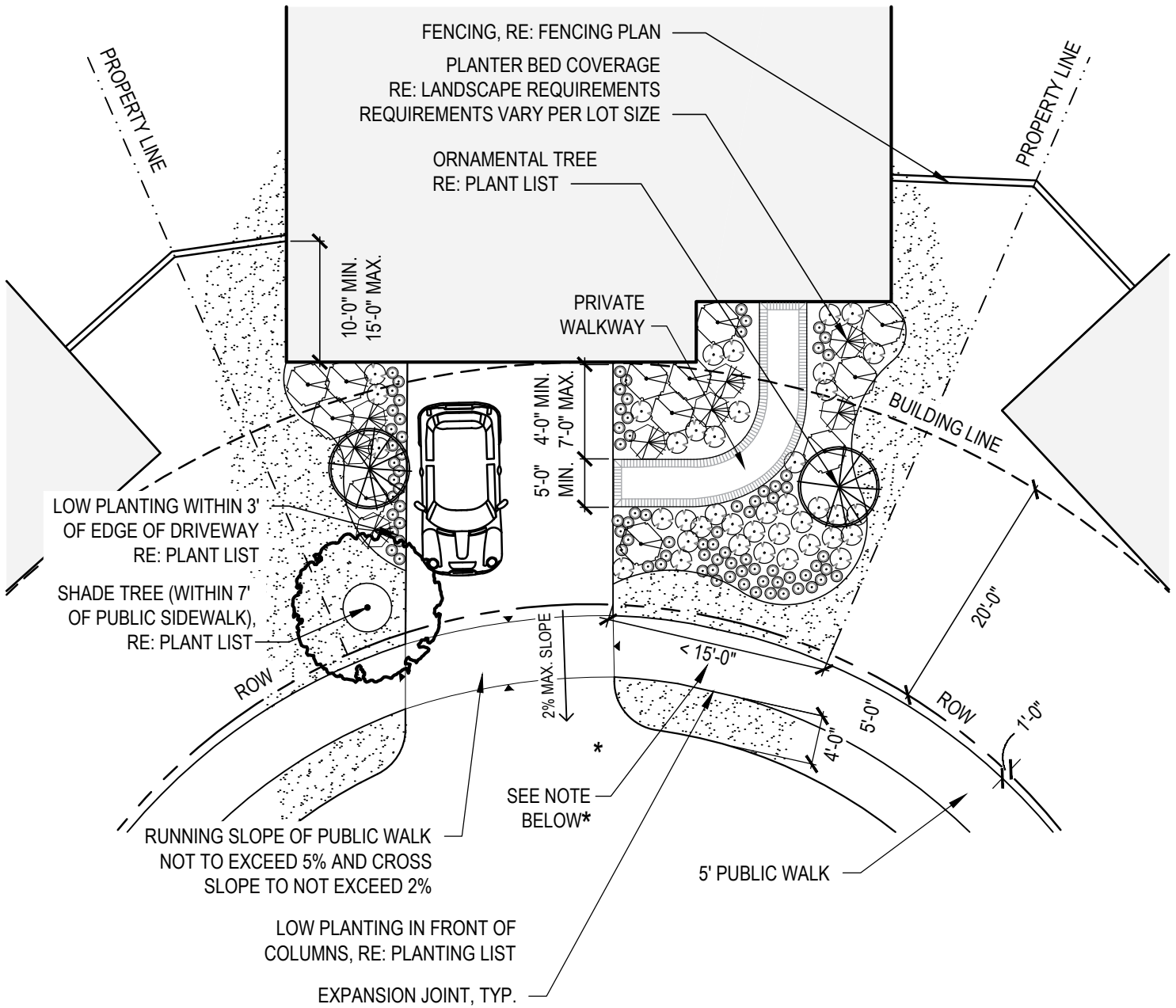

NOTES

- \* THIS EXHIBIT IS ONLY APPLICABLE IF THE WIDTH OF THE LOT, AT THE FRONT PROPERTY LINE, MEASURED BETWEEN THE DRIVEWAY AND THE SIDE PROPERTY LINE IS LESS THAN FIFTEEN (15') FEET WIDE.
- FRONT YARD TO REQUIRE FULL IRRIGATION.
- SOD SHALL BE TIFWAY 419 BERMUDA.
- PLANTER BED COVERAGE TO REQUIRE 2"-3" OF HARDWOOD MULCH.
- PLANTING SHALL NOT IMPEDE LOT DRAINAGE.
- SHADE TREES IN REAR YARD TO BE 2 1/2" CAL.
- \*\*PLANTER BED COVERAGE TO CONSIST OF MIN. 50% EVERGREEN PLANTING, 20% ORNAMENTAL GRASS PLANTING & 30% ADDITIONAL PLANTING.
- ORNAMENTAL & SHADE TREES SHALL NOT BE PLANTED WITHIN THREE (3) FEET OF DRIVEWAY.

NARROW "PIE-SHAPED" LOT REQUIREMENTS

| ITEM   | QUANTITY         |
|--|------------------|
| FRONT YARD SHADE TREES                       | 1 - (4" CALIPER) |
| ORNAMENTAL TREES                             | 1                |
| PLANTER BED COVERAGE**                       | 40% MIN.         |
| REAR YARD SHADE TREES                        | VARIES           |
| REAR YARD ORNAMENTAL TREES (ON AMENITY LOTS) | VARIES           |

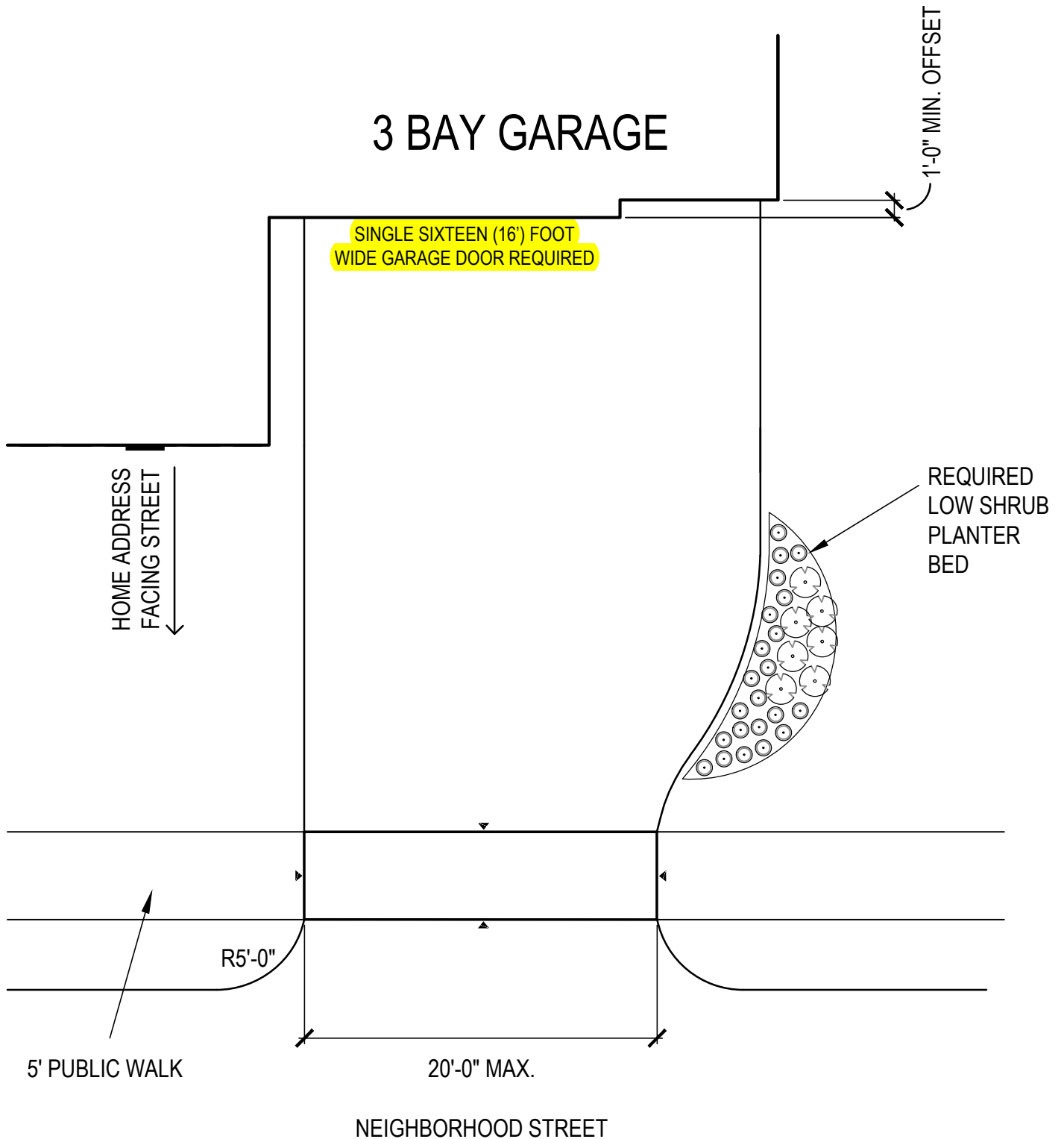

▲ EXPANSION JOINT, TYP.

- NOTES**
1. A PLANTER BED WITH A MIX OF LOW SHRUBS MUST BE INSTALLED AND MAINTAINED AT THE PORTION OF THE DRIVEWAY WHERE THE TAPER OCCURS.
  2. SPECIAL ATTENTION SHOULD BE GIVEN TO THIS PLANTER BED DESIGN AND ITS SHRUB HEIGHTS IN ORDER TO MAINTAIN A SAFE LINE-OF-SIGHT / ALLOW ADEQUATE VISIBILITY FROM MOTORISTS BACKING OUT OF THE DRIVEWAY TO ONCOMING TRAFFIC, CYCLISTS, AND PEDESTRIANS (ESPECIALLY CHILDREN).

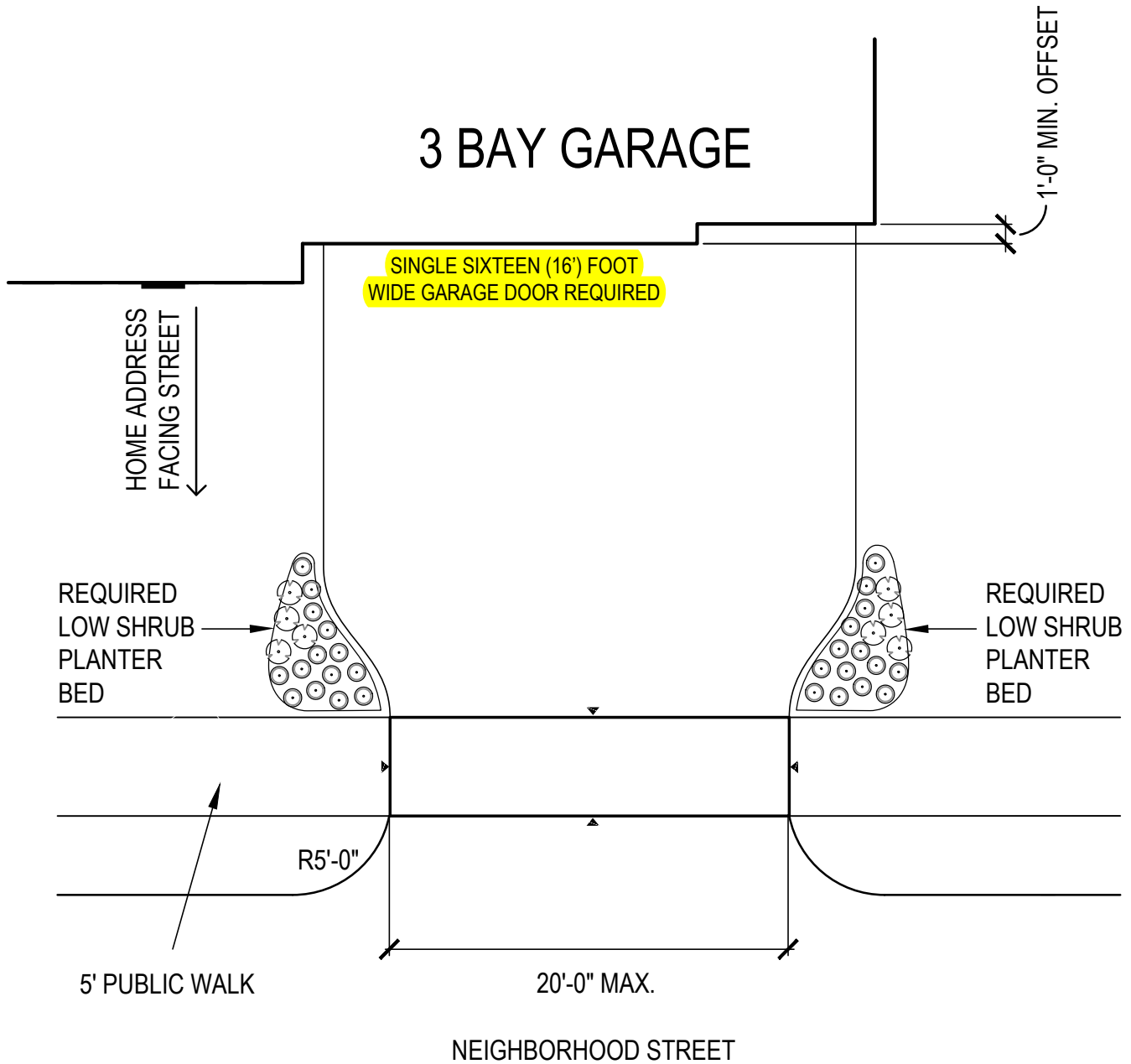

▲ EXPANSION JOINT, TYP.

- NOTES**
1. A PLANTER BED WITH A MIX OF LOW SHRUBS MUST BE INSTALLED AND MAINTAINED AT THE PORTION OF THE DRIVEWAY WHERE THE TAPER OCCURS.
  2. SPECIAL ATTENTION SHOULD BE GIVEN TO THIS PLANTER BED DESIGN AND ITS SHRUB HEIGHTS IN ORDER TO MAINTAIN A SAFE LINE-OF-SIGHT / ALLOW ADEQUATE VISIBILITY FROM MOTORISTS BACKING OUT OF THE DRIVEWAY TO ONCOMING TRAFFIC, CYCLISTS, AND PEDESTRIANS (ESPECIALLY CHILDREN).

DOUBLE SIDED WOOD FENCE- TYPICAL

SCALE: NTS

D1

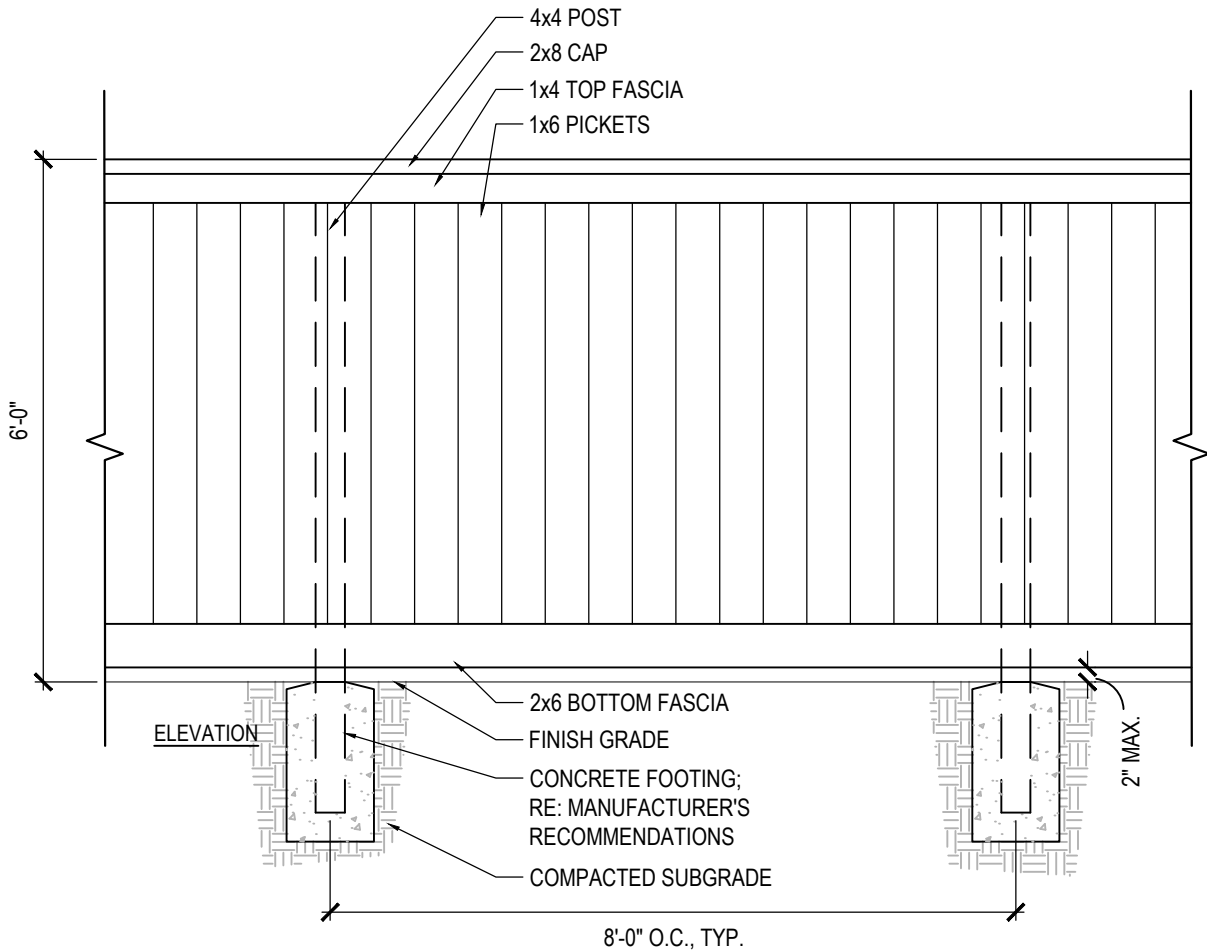
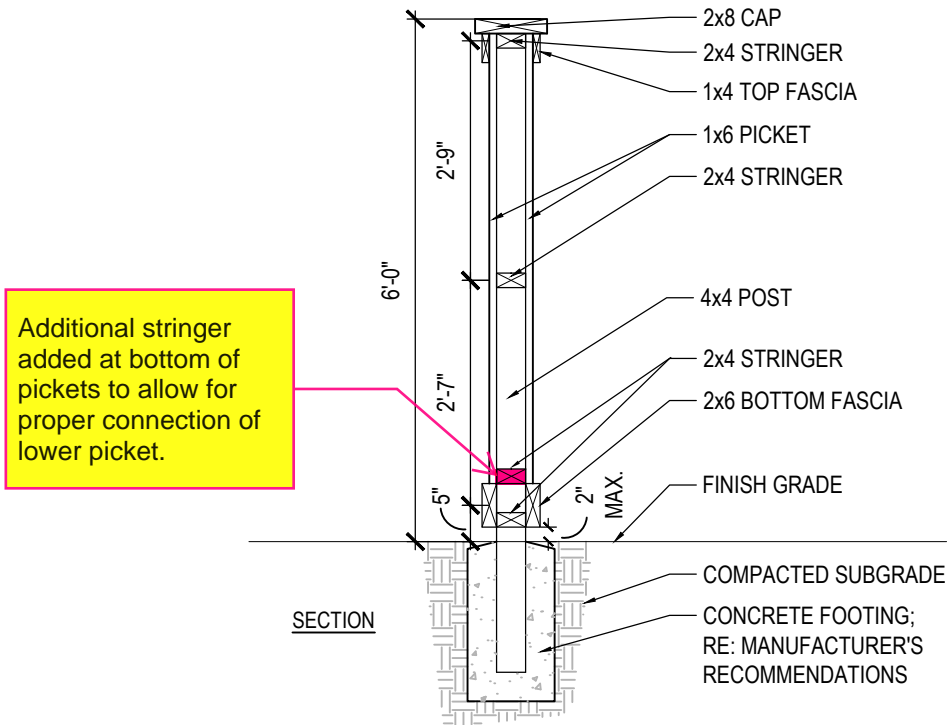

# DOUBLE SIDED WOOD FENCE ON SLOPE - TYPICAL

SCALE: NTS

# D2

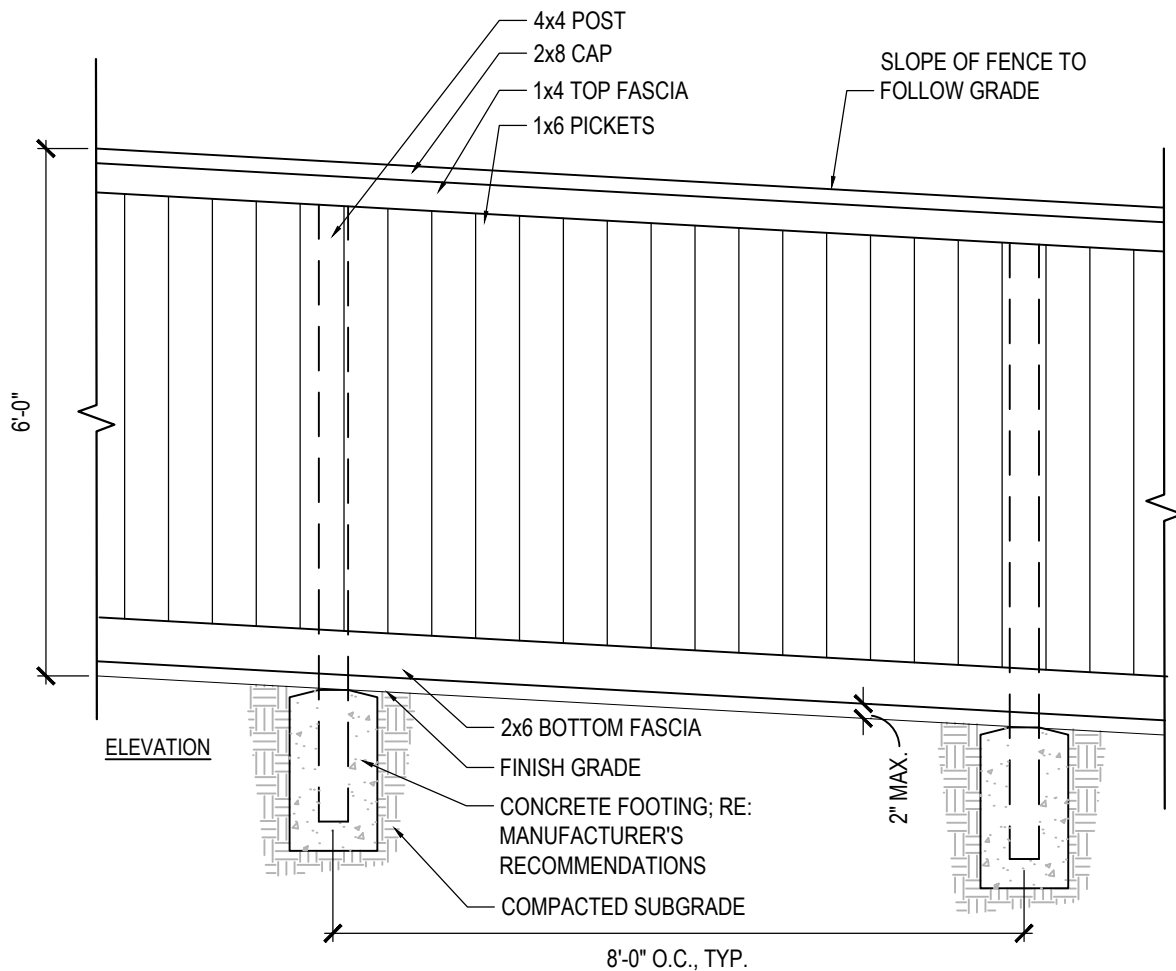
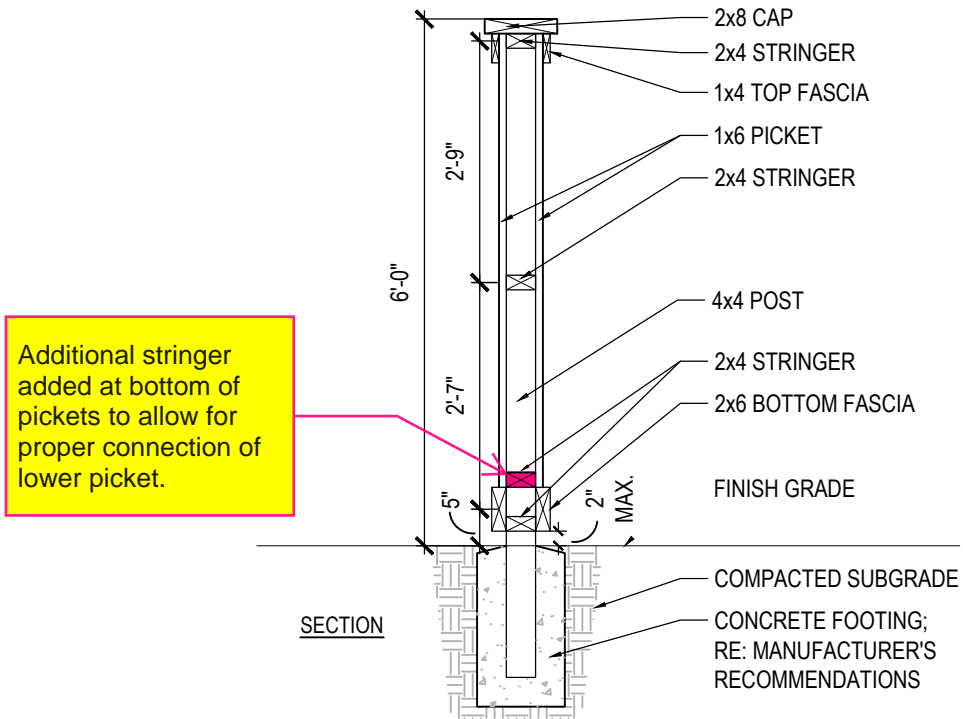

**VIII. SECTION FENCE & DRIVEWAY LAYOUTS**

Section Fence & Driveway Layouts are available at [www.KenAnderson.com](http://www.KenAnderson.com)

**IX. Supplemental Guidelines**

All supplemental guidelines will be found on the pages that follow.

All of the following  
Supplemental Guidelines  
have been added since the original version  
of these Residential Standards.