

BRIDGELAND

May 8, 2026

Residential New Construction Development Standards - Creekland

I. GENERAL	5
1.1 INTRODUCTION TO BRIDGELAND	5
1.2 MISSION STATEMENT	5
1.3 BRIDGELAND ORGANIZATION	5
1.4 DOCUMENT PHILOSOPHY	5
1.5 DEFINITIONS	5
1.6 RESIDENTIAL VILLAGE	7
1.7 COMMUNITY LOGO	7
II. SITE DESIGN	8
2.1 SITE DESIGN PHILOSOPHY-THE “BIG-IDEAS”	8
2.2 COMMUNITY AND NEIGHBORHOOD STANDARDS	8
2.3 LOT SIZES/STREET FRONTAGES/NEIGHBORHOODS	8
2.4 STREET RELATIONSHIP	8
2.5 HOUSE LOCATION ON LOT	8
2.6 SETBACKS	9
2.7 PRIVATE WALKWAY ACCENT WALLS	9
2.8 PRIVATE WALKWAYS	10
2.9 PUBLIC SIDEWALKS	10
2.10 DRIVEWAYS	11
2.11 UTILITIES	12
2.12 CARPORTS	12
2.13 POOLS AND SPAS	12
2.14 PRIVATE WALKWAY ACCENT WALL GRADING REQUIREMENTS	14
III. ARCHITECTURAL DESIGN	15
3.1 PHILOSOPHY-THE “BIG IDEAS”	15
3.2 OVERALL MASSING	15
3.3 INDIVIDUAL ELEMENTS	15
3.4 ARCHITECTURE	18
IV. FENCING	24
4.1 GENERAL	24
4.2 FENCE RESPONSIBILITY	24
4.3 FENCE TYPES & REQUIREMENTS	24
4.4 FENCE LOCATIONS	24
4.5 FENCING DIAGRAMS	26
4.6 GATES	26
V. LANDSCAPE	28
5.1 GENERAL	28
5.2 LANDSCAPE APPROACH	28
5.3 IRRIGATION	28
5.4 BOULDERS/ROCKS IN THE RIGHT-OF-WAY	28
5.5 LANDSCAPING COMPONENTS	29
5.6 YARD ZONE DEFINITIONS	29
5.7 FRONT YARD LANDSCAPE	29
5.8 SIDE YARD LANDSCAPE - CORNER LOT	29
5.9 REAR YARD LANDSCAPE	30
5.10 PLANT QUANTITY REQUIREMENTS	30
5.11 ENERGY CONSERVATION	30
5.12 TREE PROTECTION AND PRESERVATION	30
VI. PROCEDURES & SUBMISSIONS	32
6.1 GENERAL	32
6.2 SCOPE OF THIS DOCUMENT	32

6.3	PROCEDURE	32
6.4	REQUIRED SUBMISSION INFORMATION	32
6.5	QUALITY OF SUBMISSION CONTENT	33
6.6	SUBMISSION TIMING.....	33
6.7	SUBMISSION FEES.....	33
6.8	ARC ACTION ON SUBMITTALS	33
6.9	EXPIRATION OF PERMITS.....	33
6.10	VARIANCES	34
6.11	APPEALS.....	34
6.12	CONSTRUCTION TIMELINE.....	34
6.13	FINAL COMPLIANCE INSPECTION PROCEDURES, PENALTIES, AND VARIANCES.....	34
6.14	REMEDIES.....	35
6.15	CHANGES IN REVIEW PROCESS.....	35
6.16	GOVERNMENTAL REGULATIONS	35
6.17	JOB SITE PROCEDURES	36
VII.	EXHIBITS & DIAGRAMS	38
	EXHIBIT "A1" – STANDARD NOTES	39
	EXHIBIT "A2.1" – PRIVATE WALKWAY & ACCENT WALL - TYPICAL PLAN	40
	EXHIBIT "A2.2" – PRIVATE WALKWAY & ACCENT WALL - ALTERNATIVE PLAN	41
	EXHIBIT "A3.1" – PRIVATE WALKWAY & ACCENT WALL - TYPICAL PLAN (ENLARGEMENT)	42
	EXHIBIT "A3.2" – PRIVATE WALKWAY & ACCENT WALL - ALTERNATIVE PLAN "A" (ENLARGEMENT)	43
	EXHIBIT "A3.3" – PRIVATE WALKWAY & ACCENT WALL - ALTERNATIVE PLAN "B" (ENLARGEMENT)	44
	EXHIBIT "A3.4" – PRIVATE WALKWAY & ACCENT WALL – ADDRESS MARKER ALTERNATIVE PLAN	45
	EXHIBIT "A4" – PRIVATE WALKWAY & ACCENT WALL - TYPICAL ELEVATION.....	46
	EXHIBIT "A5" – PRIVATE WALKWAY & ACCENT WALL - TYPICAL DETAIL.....	47
	EXHIBIT "A6" – FRONT YARD GRADING - TYPICAL	48
	EXHIBIT "A7" – CONCRETE WALK - TYPICAL.....	49
	EXHIBIT "A8" – EXPANSION & CONTROL JOINT LAYOUT - TYPICAL.....	50
	EXHIBIT "B1" – TYPICAL ZONES: FRONT YARD, SIDE YARD & REAR YARD	51
	EXHIBIT "B2" – LANDSCAPE REQUIREMENTS: 50' & LOWER.....	52
	EXHIBIT "B3" – LANDSCAPE REQUIREMENTS: 55' - 65'	53
	EXHIBIT "B4" – LANDSCAPE REQUIREMENTS: 70' - 80'	54
	EXHIBIT "B5" – LANDSCAPE REQUIREMENTS: 100' & GREATER.....	55
	EXHIBIT "B6" – LANDSCAPE REQUIREMENTS: CUL-DE-SAC	56
	EXHIBIT "B7" – LANDSCAPE REQUIREMENT: SIDE YARD (FRONT-LOADED CORNER LOT) - TYPICAL.....	57
	EXHIBIT "B8" – LANDSCAPE REQUIREMENT: SIDE YARD (AT LAKE) - TYPICAL.....	58
	EXHIBIT "B9" – LANDSCAPE REQUIREMENT: SIDE YARD (AT GREENBELT) - TYPICAL.....	59
	EXHIBIT "B10" – LANDSCAPE REQUIREMENT: REAR YARD (AT LAKE)	60
	EXHIBIT "B11" – LANDSCAPE REQUIREMENT: REAR YARD (AT GREENBELT, WALKING TRAIL, PARK, ETC.)	61
	EXHIBIT "B12" – RESIDENTIAL PLANT LIST	62
	EXHIBIT "C1" – 2-CAR GARAGE & DRIVEWAY - TYPICAL.....	64
	EXHIBIT "C2-A" – 3-CAR GARAGE & DRIVEWAY – OPTION "A"	65
	EXHIBIT "C2-B" – 3-CAR GARAGE & DRIVEWAY – OPTION "B"	66
	EXHIBIT "D1" – FENCE: DOUBLE-SIDED WOOD - TYPICAL.....	67
	EXHIBIT "D2" – FENCE: DOUBLE-SIDED WOOD (ON SLOPE) - TYPICAL.....	68
	EXHIBIT "D3" – FENCE: TUBE STEEL - TYPICAL	69
	EXHIBIT "D4-A" – FENCE: 6' SINGLE WYTHE BRICK (DEVELOPER INSTALLED) - TYPICAL	70
	EXHIBIT "D4-B" – FENCE: 8' SINGLE WYTHE BRICK (DEVELOPER INSTALLED) - TYPICAL.....	71
	EXHIBIT "D4-C" – FENCE: FENCECRETE (DEVELOPER INSTALLED) - TYPICAL	72
	EXHIBIT "D5" – FENCING REQUIREMENT: INTERIOR LOT – TYPICAL	73
	EXHIBIT "D6" – FENCING REQUIREMENT: CORNER LOT - TYPICAL	74
	EXHIBIT "D7" – FENCING REQUIREMENT: CORNER LOT (FRONT LOADED) - TYPICAL	75
	EXHIBIT "D8" – FENCING REQUIREMENT: LANDSCAPE RESERVE - TYPICAL.....	76
	EXHIBIT "D9" – FENCING REQUIREMENT: LAKE EDGE - TYPICAL	77
	EXHIBIT "D10" – FENCING REQUIREMENT: SIDE YARD (AT LAKE) – TYPICAL	78
	EXHIBIT "D11" – FENCING REQUIREMENT: REAR YARD (AT GREENBELT, WALKING TRAIL, PARK, ETC.) – TYPICAL	79
	EXHIBIT "E1" – ADDRESS MARKER DETAILS	80

EXHIBIT "E2" – ADDRESS MARKER DETAILS 81

VIII. SECTION FENCE & DRIVEWAY LAYOUTS..... 82

IX. SUPPLEMENTAL GUIDELINES 83

I. GENERAL

1.1 Introduction to Bridgeland

Bridgeland is a new town development of over 10,000 acres, strategically located in the northwest portion of Harris County, between I-10 and US 290, along the Grand Parkway.

The Developer of Bridgeland, The Howard Hughes Corporation, has a significant and successful heritage in creating community environments of special character. The plan for Bridgeland reflects the best aspects of current community planning in Houston and around the country with additional planning concepts which make it distinctive.

Bridgeland is much more than a residential master planned community. By virtue of its significant size, Bridgeland is being developed in a creative and comprehensive way with a variety of land uses organized to create a real “new town”, one which is much more than the sum of the various parts.

1.2 Mission Statement

The Bridgeland Mission Statement is as follows:

In the vibrant town that is Bridgeland, excellence and opportunity prevail. Every facet of the town’s extraordinary beauty will be reflected in its homes, open areas and public centers. Programs that foster human growth and potential, combined with a universal spirit of citizenship and desire to excel, will inspire a more meaningful life for all, while supporting the continued enrichment and growth of Houston.

1.3 Bridgeland Organization

The physical plan is composed of a Town Center centrally located within Bridgeland and along the Grand Parkway and a series of residential villages organized by a series of lakes, trails, or roads.

1.4 Document Philosophy

Achieving this mission will require the joint efforts of the Developer and individual builders. These Standards establish criteria and procedures to guide builders, and their architects, engineers, and other designers in working with the Developer to achieve a physical environment that establishes the new town of Bridgeland as one of the most desirable locations in the Houston area.

The Bridgeland Architectural Review Committee (ARC) will administer these criteria.

1.5 Definitions

The following definitions are provided to ensure a common understanding of important terms used in this document.

Amenity

A desirable feature, facility or location in the community, such as a: Lake, Reserve, Preserve, Public Venue, Park, side street (Corner Lots), etc.

Amenity Lot

A lot which fronts, side and/or rears a desirable feature, facility or location in the community, such as a: Lake, Reserve, Preserve, Public Venue, Park, street (corner lots), etc.

Applicant

Any Builder or other entity who or which has made or intends to make a submittal to the ARC.

Bridgeland Architectural Review Committee (ARC)

A special committee established by the Developer to review and approve all proposals made for improvements within Bridgeland.

Bridgeland Development Standards

A document containing basic planning principals, general development program, the development review process and standards required for development within Bridgeland.

Corner Lot

A lot bounded by street right of way or landscape reserve on at least two sides.

Developer

The Howard Hughes Corporation, and its successor or assigns.

Easement

The right of another party (e.g., a utility company, governmental authority, etc.) to use a portion of an individual property for a limited purpose, as set out in a plat, the Covenants, or an Easement agreement recorded in the Harris County Real Property Records. The Easements established by the Covenants (the "Covenant Easements") affect all lots and provide a buffer zone between properties to minimize the impact of one lot upon the other. They are set aside to provide utility service and drainage to the surrounding area, and natural vegetative screening and privacy separations between lots. Many lots in Bridgeland are also affected by Drainage Easements (D.E.), Storm Sewer Easements (S.S.E.), Sanitary Sewer Easements (S.E.), Utility Easements (U.E.), Access and Utility Easements (A.U.E.), and Pathway Easement (P.E.).

Front Façade

The most predominant front plane of the dwelling/attached garage, generally, parallel to the street right-of-way and usually defined by the front corners of the dwelling/attached garage structure which extend nearest to the side lot lines. The front façade of a dwelling may be a different depth from the front property line on each side of the house, depending on the house design.

Front Yard

The portion of a lot between the front street right-of-way and the front façade of the dwelling.

Interior Lot

A lot which faces a public right of way only on the front and which has other residential lots adjacent on both sides.

Improvement

Is the placement, construction, alteration or repair of any structure, including, but not limited to, adding or removing square footage to or from a structure, painting or repainting a structure, or in any way altering the construction, size, shape or physical appearance of the interior or exterior of a structure. Improvements may be either permanent that is, affixed to the ground, or temporary.

Landscaping

The combination of natural elements such as trees, shrubs, ground covers, vines, and other living organic and inorganic material.

Neighborhood

A Neighborhood is a collection of Sections. Each Neighborhood has characteristics that distinguish it from other neighborhoods.

Owner

The owner of record title to the fee interest in any tract of land, whether or not they reside on the tract.

Plat

A map of land divisions within Bridgeland that shows individual lots, property lines, building setback lines, streets, certain easements and other matters. Plats are legal documents recorded in the Real Property Records in the Harris County Clerk's Office.

Property Survey

A scale drawing of an individual lot showing all Easements, platted Building Lines, and the exact location of all structures and improvements within the lot, prepared and certified by a surveyor or engineer.

Rear Yard

The portion of a lot between the rear face of the house and the rear property line.

Section

A Section is a specified collection of residential streets, lots and reserves.

Side Yard

The portion of a lot between the Front Yard and the Rear Yard and extending to the street on the street side of a Corner Lot.

Sign

Any device, structure, fixture or placard using graphics, symbols and/or written copy of the primary purpose of identification or advertising any establishment, product, goods or services.

Single-Family Dwelling

A structure designed for the residential use of a single family.

Single-Family Lot

A lot or tract of land upon which one or more Single-Family Dwellings has or will be built.

Street Rights-of-Way

The street right-of-way are the areas between platted lot lines on one side of the street and platted lot lines on the opposite side of the street, including the paved roadway, any median or cul-de-sac islands, the drainage ditch (if any) and a strip of land, usually from ten (10') to fifteen (15') feet wide, between the paved roadway and the platted lot line. Street rights-of-way are dedicated to the county or other public bodies for public access, drainage and utility purposes. Street rights-of-way are usually shown on the plat of a subdivision.

UE

Utility Easement

Village

Bridgeland will be composed of four residential Villages. Each Village is composed of a series of Neighborhoods.

1.6 Residential Village

Each of the residential villages will have its own name/identity within Bridgeland.

1.7 Community Logo

The officially adopted logo and logotype of Bridgeland shall only be used in reference to the Bridgeland community. All other uses shall be approved in writing by the developer. The use of the logo and logotype for advertising and marketing material is encouraged, but is an official trademark and requires permission for use. No modifications to the logo or logotype will be allowed.

II. SITE DESIGN

2.1 Site Design Philosophy-the “Big-Ideas”

The land planning for Bridgeland is focused on creating a distinctive water-side new town. The nature of the overall street system (thoroughfares/collectors/residential streets), the overall residential hierarchy (community/village/neighborhood/section), and the relationship to amenities (water/parks/trails/activity centers) reflect a consistent approach. The Land Plan emphasizes desirable views of water, open space and other amenities, while minimizing the less desirable views, such as that of rear fences, etc. to enhance the life of the Bridgeland residents.

2.2 Community and Neighborhood Standards

Within individual residential neighborhoods, some particular design considerations may vary, reflecting the character of that particular area. Therefore, some portions of these development standards will apply universally throughout Bridgeland, while some standards and criteria may be particular to an individual village, neighborhood, section or even to lots within a neighborhood.

2.3 Lot Sizes/Street Frontages/Neighborhoods

Within the various neighborhoods, lot sizes/street frontages range from fifty (50') feet and under in width up to and including some lots over one-hundred (100') feet in width. These lot sizes are grouped primarily by size within individual neighborhoods. Unless otherwise specified, the standards for lots within a neighborhood shall apply to the whole neighborhood, regardless of specific lot size/street frontage.

2.4 Street Relationship

The overall appearance of the streetscape will be a major part of the impression of Bridgeland. There are various elements that contribute to the streetscape impression including: the houses, the house location on the lot, the garage location and the position of the drive, the landscaping in the right of way and the landscaping on the lots.

2.5 House Location on Lot

In determining the location of the house, the following factors should be considered:

- Visibility from street
- Shape of lot
- Floor plan
- Setbacks
- Relationship to adjacent houses
- Relationship to lakes
- Amenities

A. Detached Garages

Detached Garages in rear yards are encouraged. On corner lots, the garage may be detached with the door facing the side street or opposite on the street side with driveways extending to the front street. Detached garages backing towards a lake are prohibited. Detached garages shall be setback a minimum of five (5') feet from an interior side lot line. In order to provide space for parked vehicles, a detached or side loading garage on the side street side of a corner lot shall be set back a minimum of twenty (20') feet from the curb.

B. 3-Car Garages

3-Car Garages will be allowed if they fit fully within the lot setbacks.

C. Decks and Patios

Decks shall be setback at least five (5') feet from any property line and in general, shall be behind the rear

line of the house. Where the rear has several planes, the ARC will make an individual judgment. Decks and patios may be placed within the utility easement; however, the utility company has a right to remove them at the Builder's/ Homeowner's sole expense.

Acceptable materials for decks and patios are to be at the discretion of the ARC.

Suggested materials are:

- Concrete
- Paver
- Wood Trex© or comparable

2.6 Setbacks

Front setbacks for houses are shown on the plat and are restated in the exhibits that are part of this document. Side and rear yard minimum setbacks may be shown on the plats, and in the chart below.

ELEMENT	SETBACK	INTERIOR LOTS	CORNER LOTS
House	Front	20'	20'
House (Patio)	Front	10'	10'
House	Interior Side	5'	5'
House	Street Side	N/A	10'
House (Patio)	Zero Side	0'	N/A
House (Patio)	Non-Zero Side	10'	10'
House (1 Story)	Rear	10'	10'
House (2 Story)	Rear	20'	20'
Garage (Attached)	Front	20'	20'
Garage (Detached)	Rear	(7.5' or UE)*	(7.5' or UE)*
Garage (Detached/Side Loading)	Side	3'	15'
Driveway	Interior Side	4'	N/A
Porches	Rear & Side	5'	5'
Decks	Rear & Side	5'	5'
Patios	Rear & Side	5'	5'
Pool Deck	Rear	5'	5'
Pool Deck	Side	5'	15'

* *Whichever is greater*

2.7 Private Walkway Accent Walls

In keeping with the theme of Bridgeland to create a traditional neighborhood character, all lots, unless otherwise stated within these Standards, will incorporate a front yard private walkway accent wall.

All masonry/brick materials used for the private walkway accent wall shall be the same materials used for the house and will need to be in the same sequence/stacking order as the house. Typically, a brick cap with brick or stone on the bottom. No cast stone will be permitted.

(Reference Exhibits: "A2.1 – A8")

A. Lots: 50' & Less

Lots fifty (50') feet wide and less shall have:

- Masonry private walkway accent walls shall be installed per the exhibit.

(Reference Exhibit: "A2.1 – A8 & B2")

B. Lots: 55' - 65'

Lots fifty-five (55') feet to sixty-five (65') feet wide shall have:

- Masonry private walkway accent walls shall be installed per the exhibit.

(Reference Exhibit: "A2.1 – A8 & B3")

C. Lots: 70' - 80'

Lots seventy (70') feet to eighty (80') feet wide shall have:

- Masonry private walkway accent walls shall be installed per the exhibit.

(Reference Exhibit: "A2.1 – A8 & B4")

D. Lots: 100' & Greater

Lots one hundred (100') feet wide and greater shall have:

- Masonry private walkway accent walls shall be installed per the exhibit.

(Reference Exhibit: "A2.1 – A8 & B5")

E. Lots: Cul-de-Sac

All Cul-de-Sac Lots shall have:

- Masonry private walkway accent walls shall be installed per the exhibit.

(Reference Exhibit: "A2.1 – A8 & B6")

2.8 Private Walkways

A four (4') foot private walkway is required to extend from the front door and extend to the driveway. Private walkways shall be right angled.

(Reference Exhibit: "A2.1 – A8")

2.9 Public Sidewalks

A five (5') foot public sidewalk is also required on the front of all lots. The public sidewalk shall be located along the inside edge of the R.O.W./Property Line, between the property pin/line and the back-of-curb, and shall not encroach beyond the property pins/line into the front yard of the home.

A. Corner Lots

On Corner Lots, the five (5') foot public sidewalk is required across both the front of the Lot and at the side street.

B. Cul-de-Sac Lots

The public sidewalk shall be located along the inside edge of the R.O.W./Property Line, between the property pin and the back-of-curb, and shall not encroach beyond the property pins/line into the front yard of the home.

Per TDLR standards, sidewalks shall have a maximum side slope of two (2%) percent and a maximum running slope of five (5%) percent, this includes where public sidewalks cross driveways. All public sidewalks must be doweled and properly reinforced.

(Reference Exhibit: "A6 – B1")

2.10 Driveways

Driveway locations are as depicted on Section Fencing & Driveway Layout Exhibits. The ARC may grant variances to site specific situations as it deems appropriate. All driveway designs are subject to review by the ARC. Driveways shall typically cross the building setback area in a straight line at a ninety (90) degree angle to the street right-of-way. Where this may not be feasible due to the particular conditions of a lot, the alignment of the driveway shall be direct and logical. Turnaround or circular drives may be allowed on certain sized lots and with certain architectural styles. Under no circumstance may an entire front yard be paved as a driveway.

A. Driveway Responsibility/Construction

Builders are required to build the driveway out to the street. Most lots have a mountable curb at the street. Driveways are to be a minimum of three and one-half inches (3.5") thick over a sand base. Six by six (6x6) woven wire mesh shall be installed within the apron of the driveway as a minimum. Expansion joints between the curb and driveway are required as illustrated. Where barrier curbs exist, saw cut into existing street and dowel into existing concrete paving. Where the driveways intersect the sidewalk and front walks, the driveway finish may not continue through the sidewalk. The radius at the curb shall be five feet (as necessary to meet sidewalk edge). Sidewalks shall not have a side slope greater than two (2%) percent and a running slope greater than five (5%) percent.

B. Driveway Widths

(1) Two-Car Garages

(a) Driveways serving two-car garages with a single garage door, facing the street, shall be:

- **Minimum Width:**
Twelve feet (12')
- **Maximum Width:**
Sixteen feet (16')
- No wider than the garage door (at the garage).

(Reference Exhibit: "C1")

(b) Driveways serving two-car garages with two single garage doors, facing the street, shall be:

- **Minimum Width:**
Twelve feet (12')
- **Maximum Width:**

Sixteen feet (16') from the front plain of the garage, equally taper both sides of the driveway down to Sixteen feet (16') maximum width at the public sidewalk.

- No wider than the garage door (at the garage).

(2) Three-Car Garage

Driveways serving three-car garages, when all garage doors face or are parallel to the street, shall be:

- **Maximum Width (at garage):**
Thirty-two feet (32') and no wider than garage door.
- **Maximum Width (at public sidewalk):**
Twenty feet (20')

The builder may choose one (1) of two (2) driveway configuration options for homes with three car garages. Selected driveway configuration must be shown on the site plan at the time the building permit application is submitted.

A planter bed with a mix of low shrubs must be installed and maintained at the portion of the driveway where the taper occurs. Special attention should be given to this planter bed design and its shrub heights in order to maintain a safe line-of-sight / allow adequate visibility from motorists backing out of the driveway to oncoming traffic, cyclists, and pedestrians (especially children).

(Reference Exhibit: "C2-A" & "C2-B")

(3) Swing-In Garage

Driveways serving swing-in garages, shall be:

- **Maximum Width:**
Twenty-eight feet (28')
- **Maximum Width (at public sidewalk):**
Sixteen feet (16')
- No wider than the garage door (at the garage).

2.11 Utilities

If it can be avoided, driveways shall not be constructed over inlets or manholes. In instances where this may be unavoidable, compliance with County regulations that may require inlet adjustments and/ or upgrades may be necessary.

2.12 Carports

Carports are not permitted on any lot.

2.13 Pools and Spas

Portable or permanent above ground swimming pools are prohibited. Smaller, prefabricated above ground hot tubs are acceptable if part of an integrated deck system. If visible from public view or from other lots they shall be skirted, decked, screened, or landscaped to hide all plumbing, heaters, pumps, filters, etc. Swimming pool appurtenances as rock waterfalls and sliding boards shall not be over six feet (6') in height. Skimmer nets, long handle brushes, pool chemicals, filters, pumps, heaters, plumbing, etc. shall not be visible from public view.

Pool Walls shall not encroach on utility easements. If pool plumbing is required in utility easements, contact the local utility company before digging. Wood or concrete pool decks may be placed on utility easements, but are subject to removal by utility companies and replacement will be at the lot Owner's sole expense.

Pool decks shall be set back a minimum of five (5') feet from the side building setback and a minimum of five (5') feet from the rear property line. All pools and spas, with a site and landscaping plan, shall be approved in writing by the ARC prior to construction.

Other requirements: *(On the following page.)*

A. Drains

Pool and backwash drains shall discharge into the sanitary sewer system at connections approved by the MUD.

B. Dwelling Foundation

The Owner should obtain competent engineering advice to determine that the swimming pool is located far enough from the dwelling foundation to maintain support for the foundation.

C. Elevation

The pool should be elevated above the surrounding grade a sufficient height to not permit an inflow of storm water.

D. Excavation

Excess soil from a swimming pool excavation shall be removed from the site by the lot Owner.

E. Lights

Lights in or around swimming pools shall be included on the plan for review and approval.

F. Construction Access

There shall be no construction access from any lake or Common Area unless prior written permission is granted by the HOA and/or ARC.

G. Damage Deposit

A damage deposit must be posted by the Owner or Builder prior to any construction to cover any damage caused to common property.

H. Grading/ Drainage

The Owner shall ensure that the placement of any improvement or landscaping does not halt or materially impede drainage flowing off a neighboring tract, and does not redirect the flow or significantly increase the amount of water flowing onto a neighboring tract. Enforcement of this requirement is by the affected property Owner(s).

Graded slopes shall not exceed 3:1. All slopes shall be properly stabilized to prevent erosion. Lawn areas should have slopes of at least two (2%) percent to prevent standing water. Generally, driveway slopes should not exceed five (5%) percent.

I. Grading at Lot Perimeters General

Grading beyond lot boundaries is not allowed unless approved in writing and in advance by the master developer. Any damage to areas outside the lot caused by construction activity shall be repaired at the home builder's sole expense.

J. Drainage onto Adjoining Lots

Adjoining properties shall be protected from flooding or surface drainage.

K. Parcel Drainage

Drainage discharge points for each neighborhood and community have been predetermined. Grading at lot edges should provide for positive drainage away from perimeter property lines and back towards internal street or drainage facilities.

On waterfront lots, special attention should be paid to controlling runoff into the adjacent body of water especially during construction. Waterfront lots include lots that are adjacent to lakes, bayous, ponds, or any other water body or wetland.

Wherever possible, drainage shall be directed away from this body of water to avoid soil, fertilizer, pesticides, petroleum products, and other chemical runoff. These concerns apply both during and after construction. The dumping of any foreign material into the water body is strictly prohibited.

The eighteen (18") inch terrace grading with a two (2%) percent slope at the curb for the public sidewalk, shall be maintained or replaced after construction of the house.

2.14 Private Walkway Accent Wall Grading Requirements

(Reference Exhibit: "A6")

III. ARCHITECTURAL DESIGN

3.1 Philosophy-the “Big Ideas”

The standards in this section provide a basis for developing the design concepts, forms, and materials used for homes within Bridgeland. This section identifies those architectural elements that influence the overall neighborhood appearance and perception of the street scene character. These include the appropriateness of a house design to a particular site, overall building massing, the location and visual impact of key elements like entries, garages, etc., the style of the architecture and how it relates to those around it, and the quality and quantity of the exterior materials used on the home.

3.2 Overall Massing

The house shall be sited on the lot so the house and entry are predominant and the garage minimized.

A. Height

Varied elevations and arrangements on the site are encouraged to create a more interesting street scene. More pleasing arrangements are achieved with a variety of articulated plans, which break the rectangular box into interesting three-dimensional shapes with courtyard-like spaces in and around each house. In addition to the improved footprints, the street scene is made more attractive with the combination of right and left-hand units if garages are not detached.

3.3 Individual Elements

A. Entries

The main entry shall provide an important point of interest to each home and shall be protected with overhangs, recesses, porches, or trellises. Sidelights and transoms are encouraged. When used with wall extensions, the whole entry can even result in a courtyard effect.

B. Garages

- (1) Each house shall have a garage capable of accommodating a minimum of two (2) full size automobiles and a maximum of four (4).
- (2) Two (2) car garages may use a single sixteen (16') foot wide door or two (2) single eight (8') foot or nine (9') foot wide garage doors.
- (3) Three (3) garage bays may front the street provided both of the following requirements are met:
 - (a) That the third bay is set back a minimum of twelve (12") inches from the other two bays.
 - (b) Two (2) bay garages must use a single sixteen (16') foot wide door.
 - (c) A single eight (8') foot or nine (9') foot wide garage door may only be used for the third bay.
 - (d) The lot can accommodate the configuration without any encroachments.
- (4) Additionally, a separate roofline over the third bay is preferred to break up the view from the street. Detached three car garages located in the rear yard or side yard on a corner lot will be allowed. An extension in the depth of a garage which permits additional storage space is permitted.
- (5) The front façade of front-loaded detached garages shall be the same masonry used on the main house, except at garage door headers, where siding can be used.

- (6) Garage doors shall not exceed nine (9') foot in height of typical home garages. All garages must be the same height.
- (7) On a corner lot with a detached side loading garage the exposed wall in front of the breezeway fence must be screened by a solid hedge. Plant material is required to be a minimum five (5) gallon evergreen shrub installed at twenty-four to thirty (24"-30") inches on center. The hedges shall be of Wax Myrtle, Oleander, Elaeagnus or Burford Holly.
- (8) The garage doors shall not dominate the facade. Treatment of detail on garage doors shall be consistent with the overall character of the house. This may be accomplished with well-placed windows along the top of the garage door and by breaking up the mass with paneled construction.
- (9) All garage doors shall be a panel metal or wood design and of a color which matches the color of the adjacent wall or trim; darker colors are preferred. No particle board or fiberglass doors are permitted. Glass fenestration is permitted. No reflective film or foil is permitted on windows.

(Reference "Section 2.6" for Garage Setback requirements.)

(10) Side-entry Garages

Where a side entry garage at the front plane of the house is allowed, the wall facing the street may not be solid. Windows with shutters or blinds, and/or architectural embellishment will be required to soften the effect of the garage and will be established on a case-by-case basis based on visibility.

(11) Carports

Carports are prohibited.

(12) Garage Living Areas

Living areas above detached garages are prohibited.

C. Roofs

(1) Rooftop Elements.

The roofs shall be kept as visually unobstructed as possible. All stack vents and attic ventilators shall be located on the rear slopes of roofs and mounted perpendicular to the level ground plate. Solar collectors shall be located in the least conspicuous side while allowing for satisfactory performance. Rooftop or window HVAC equipment is not permitted under any circumstances.

(2) Roof & Porch Overhangs.

Overhangs shall be used consistently on eave conditions and rake conditions. Overhangs shall be an integral part of the building form and not thin planes extended past the mass of the house. Exposing the ends of rafters is prohibited. Porches and overhangs shall have a minimum slope of four on twelve (4/12) pitch.

(3) Roof Material

The roof material shall be dimensional asphalt shingles with a thirty (30) year warranty.

(4) Exposed Roof Penetrations

All exposed stack vents, skylight curbs, attic ventilators, and other metal roof accessories shall match or closely resemble the roofing color. Roof and valley flashing shall be of a pre-finished or painted to match the roof color. Glossy finishes are prohibited. Lacing valleys with shingles is also permitted where adequate sub-surface water protection and support is provided. Roof-mounted ventilators shall be no higher than ten (10") inches above the roof surface. Under no circumstances shall any of

the above-mentioned items extend above the ridge line or parapet on an approved flat roof. The number and size of stack vents shall be minimized.

D. Chimneys

- (1)** Chimneys can be used to establish an ornamental or thematic character. The minimum plan dimensions for an exposed mass is twenty-four inches by twenty-four inches (24" x 24") and a larger form is preferred.
- (2)** In the event of gas fireplaces, direct vents in place of chimneys are allowed, provided roof-mounted vents are located along the rear slope or rear half of the roof and painted to match the shingles. Direct vents located on exterior walls of the home must be painted the same color as the surface material they project out from.
- (3)** The height of the chimney shall be in proportion to the roof line and adhere to fire codes. Broad, massive chimneys are encouraged. Small, spindly shaped chimneys will not be approved. Chimneys which barely peak above or squat on the roof are unacceptable.
- (4)** Exposed metal flues are not allowed. They may be used only when faced with the brick/ masonry used on the house.
- (5)** Fireplaces shall be made of the same material as the house. Exterior chimneys on all lots shall have all sides constructed with brick/ masonry materials, matching the house.
- (6)** If a chimney occurs in an interior portion of the roof (not an external house edge) or at the rear or non-corner side of a home, it shall be constructed of materials that match the architectural style and color of the home. Stucco, or wood sided chimneys are permitted in these locations. Cladding metal flues with masonry, brick, or wood is required if metal flues are to be used.
- (7)** Spark arrestors and caps are required on all chimneys. The spark arrestor and cap shall be unadorned and designed to match or be compatible with the color and material of the exterior elevations of the home. Caps shall be of metal or masonry construction. Spark arrestors may not exceed the height of the chimney cap. All chimney caps must be painted with a matte finish paint to coincide with the color scheme of the home.
- (8)** Heights of chimneys shall meet all fire code requirements and be proportional to the roofline of the respective home.

E. Decks/Patios/Porches

(1) Porches

Porches are encouraged; they provide relief to elevations and architecture transition between outdoor and indoors. When a porch makes up at least fifty (50%) percent of the front elevation it, may be considered as the primary front plane of a house for calculating the garage setback.

(2) Deck/Patio Design

Any exterior deck shall read as an integral element of the house design. Front yard decks and patios will generally not be approved unless necessary to accommodate a unique feature on the lot, and when integrated into the overall entry sequence of the dwelling.

Where a patio is concrete and has an exposed foundation more than one foot in height, the edge shall be covered with landscape/shrub screening or masonry matching that on the house. Where a wood deck is two (2') feet or less above grade, the vertical plane at the edge shall be screened with a

continuous shrub planting. Where the deck is more than two (2') feet, but less than four (4') feet above the adjacent grade, the vertical plane at the edge of the deck shall be screened with framed lattice panels or masonry. Where a deck is more than four (4') feet above the adjacent grade, it shall be detailed as a porch, with substantial supports such as masonry piers, in addition to the skirting. Such a deck will only be considered if it has no impact on adjacent properties and is not visible from a street or public space. Trim board shall be used in all cases to conceal exposed joist ends. Decks shall be built with support posts of sufficient size or detail so that knee braces are not required. If a railing is required, a simple vertical picket or horizontal board railing built in a vertical plane is preferred. If stairs are part of the deck design, the stair railing shall match the deck rail and shall be included within the mass of either the deck or the house.

3.4 Architecture

A. Style

The exterior architectural style shall be in conformance with the project character of each neighborhood. A range of styles is permissible provided that a particular style is deemed appropriate by the ARC for a particular location or neighborhood. All elements of a home shall be architecturally compatible.

B. Plan Repetition

To meet the streetscape design objectives for the community the following rules apply:

- (1)** Production model mix in must avoid monotony, but maintain continuity of scale and character.
- (2)** If a plan is to be repeated with the same front elevation design on either the same side or opposite side of the street, it shall not occur more frequently than every fourth (4th) consecutive lot. Thus, where this situation exists, at least three (3) other homes shall occur between the next repeated front elevations. Brick and trim color in this situation shall be different.
- (3)** If a plan is to be repeated with a different front elevation design on the same side or opposite side of the street, it shall not occur more frequently than every third (3rd) lot. Thus, at least two (2) other homes shall occur between the next repeated floor plan with a different front elevation design. Brick and trim color shall also be different, with patio homes being an exception.

The ARC reserves the right to reject an elevation that closely resembles that of a nearby house or in any way detracts from the overall street scene. Identical uses in brick type and color, and siding color are generally prohibited on homes which are adjacent to one another.

The design of the house and particularly the placement of windows shall maintain privacy within that house, take advantage of any garden or open space views.

C. Elevation Openings

All openings in a building such as windows and doors shall relate to each other on each elevation vertically and horizontally in a clearly defined order.

Front facing gables at entries are encouraged to break down the scale of the main roof mass.

D. Detailed Elements

(1) Gutters & Downspouts

Gutters and downspouts shall be designed and installed so that water runoff does not adversely affect drainage on adjacent property. If gutters are not used, positive drainage away from the building shall be provided. Downspouts are to be located to provide a clean, unobtrusive appearance, terminated

by either splash blocks or connection to the storm sewer. Gutters and downspouts shall be integrated with architectural design in color, shape, and location. All gutters & downspouts shall be painted to match the trim of the home. Downspouts which do not occur on a corner of the home are encouraged to be painted to match the dominant wall color/material for which it is adjacent. Drain pipes tied into rain gutter downspouts shall be completely hidden from view, by shrubs or ground cover large enough and dense enough to screen.

(2) Rain Gutter Drains

Although gutters are not required, roof design or the use of diverters are encouraged to keep dripping water off of patios, balconies, stairs, doorways, etc. Positive drainage away from the house should be provided for rainfall, irrigation, air conditioner condensate and all other types of water runoff. Roof drainage that will ultimately create erosion or run across pedestrian walks and paths is not acceptable. Drainpipes tied into rain gutter down spouts shall be completely hidden from view. Plant shrubs and ground cover large enough and dense enough to screen visual obstructions. Use splash blocks where practical.

(3) Screens

Solar screens are prohibited.

(4) Address Marker & House Numbers

Address marker and house numbers shall be fabricated as shown in the exhibit. Logos of any kind are not permitted on address markers.

(Reference Exhibit "E1"- "E2" – Address Marker)

The address marker shall face the street for which the address of the home is designated.

(5) Security Devices/Bars

Security devices such as cameras, sirens and speaker boxes shall be the minimum size needed to be effective and shall be located in the least conspicuous location while allowing satisfactory performance. As previously mentioned under the section for "Entrances and Windows", security and/or burglar bars on the exterior of homes are not permitted. If security devices are being considered for a home, the builder shall utilize a device which is minimally visible to public view and preferably mostly contained within the home. Cameras are to be located under the eaves of the home and the camera(s) or their field(s) of vision shall not be placed to be focused on any neighboring property. All cabling must be concealed.

(6) Exterior Materials/Colors

The ARC will consider optional materials not included or listed below that are, in the opinion of the ARC equal or greater in quality level. Materials shall be used with restraint in regard to both color and diversity of material types. The intent is to create a continuity of materials and color throughout the neighborhood. The number of primary materials on the exterior will be limited to three (3) not including roof shingles.

(7) Painting / Colors of Pipes, Vents & Functional Louvered Vents

All wall extrusions / penetrations, equipment attached to exterior walls or similar, including, but not limited to pipes (PVC, metal, etc.), wall vents, utility meters, etc. must be the same color as the surface material they project out from or to which they are directly attached.

(8) Base Wall Material Requirements

The first level of all homes shall be one-hundred (100%) percent masonry (brick, authentic stucco or stone) on all elevations. Siding on the front elevation will only be allowed on minor elements such as,

dormers, gables, etc. on a case-by-case basis.

(9) Second Level/Story Masonry Requirements

In addition to the Base Wall Material Requirements, the second level of all side and rear elevations of a home which side or rear a street and/or amenity such as, but not limited to, a lake, greenbelt, trail, side street (corner lots) or are otherwise visible to the public, shall also be one-hundred (100%) percent masonry (brick, authentic stucco or stone) on the entire second level.

(10) Wall Material Transitions

All transitions between materials shall occur at logical points in the elevation. Where there is a transition on the upper levels of a home from masonry to another approved material on a side elevation, the masonry shall extend back at least two (2') feet. Exceptions will be considered on a case-by-case basis. No material change may ever occur on an outside corner.

(11) Brick

Brick shall be hard fired and have an overall appearance of relative evenness in color and texture. Only earth tone colors are acceptable. Painted brick shall only be permitted on a case-by-case basis as determined by the ARC and shall be of a matte finish. Brick shall meet standard specifications established by The Brick Institute of America.

(12) Stone

If stone is to be incorporated, it shall be earth tones.

(13) Masonry Mortar Joints

All mortar joints shall be tooled; "slump" joints will not be allowed. Mortar colors if used, shall be selected to compliment the brick or stone color. Caulking of vertical expansion joints and border joints must match mortar color.

(14) Siding

Siding may only be used as a secondary material. Where it is used, the siding, stucco, shingles, board & batten material shall be a cementitious material or LP Smart Siding. These materials shall be of horizontal, lap type, excluding board & batten which shall be vertical.

Siding shall be painted with medium range colors. The use of wood, particle board, or any sheet siding is prohibited. Vinyl or aluminum siding is also prohibited.

(15) Stucco

If used, the use of authentic stucco is required on the front elevation. Additionally, if stucco is used on the side and/or rear elevations of homes which side or rear street and/or an amenity such as, but not limited to, a corner lot, lake, greenbelt, trail, or are otherwise visible to the public, authentic stucco must be used on all elevations of the home.

The use of matte-finished stucco board is only permitted on the sides and rear of the home if it does not side or rear a street or an amenity such as, but not limited to, a corner lot, lake, greenbelt, trail, or is otherwise visible to the public. The stucco shall conform in color with all other exterior housing materials.

(16) Trim

All trim shall be smooth/ semi-smooth, high quality finish grade stock wood or fiber cement board.

(17) Windows

Window type/color/finish shall be complimentary to the overall character of the home’s design. Mill-finish aluminum is not permitted. Reflective, “mirrored” or tinted glass is not permitted.

(18) Awnings

Awnings are prohibited.

(19) Exterior Colors

Exterior paints and stains for each residence shall be selected to complement or harmonize with the colors of the other materials with which they are used. The general intent is to encourage greater variety among homes along the street. Wood siding and trim shall generally stay within the earth tone color family. The use of white is also permitted. Extremely bold or primary colors, however, are prohibited. Yellow, blue, or green pastels are discouraged.

However, soft and muted earth tone pastel colors like gray, beige, brown, salmon, etc., are acceptable. The variety and number of exterior colors on each house shall be held to a maximum of three (3) not inclusive of brick color or front door color. Brick colors shall generally be of an earth tone family or range. No one brick color family shall dominate a particular street scene.

Dark colored brick is preferred. Brick for houses on consecutive and facing lots shall vary in order to avoid monotony. Variety in brick use is highly encouraged. Likewise, trim color and/or field color shall also vary.

All exterior paint must be flat or matte finish.

There must be a minimum of at least two (2) lots between (on the same side of the street) and two (2) lots in both directions (from the lot across the street) between homes with the same or similar paint color(s) on the main fields of a home.

In cases where two or more homes are painted the same or similar colors (as determined by the Developer and/or the ARC) within less than the minimum number of lots apart required, the builder/lot whom painted subsequent to the first will be required to repaint their home(s) to a different/non-similar color to any home within the minimum number of lots required, at the builder’s sole expense.

Failure to follow these requirements may result in the home being repainted at the builder’s sole expense.

(20) Exterior Building Lighting

(a) Any lighting on individual lots shall be directed away from adjoining property. Light sources shall not conflict with the sight lines of pedestrians or motorists in a manner which endangers their safety and welfare.

(b) Exterior lights located on the second (2nd) story of the home are prohibited (i.e. Flood lights). Flood lights are permitted only on the rear of the home and are to be located no higher than the first (1st) floor plate height. Additionally, flood lights are prohibited on the side elevations of the home and/or in the side yards.

(c) Soffit/Eve-Mounted Accent Lights

i. General

Lights may not be mounted in a way or installed in locations which will allow them to shine

onto or be a nuisance to neighboring properties.

ii. Front Elevation

Recessed soffit/eve-mounted accent lights may be used on the first (1st) story and second (2nd) story of the front elevation.

iii. Side & Rear Elevation

Recessed soffit/eve-mounted accent lights may only be used on the first (1st) story of side or rear elevations which do not face an adjacent residential lot. (i.e. A side elevation which faces either a side street on Corner Lots or faces an Amenity is authorized. A rear elevation which faces an Amenity is authorized.)

iv. If used, soffit/eve-mounted accent lights:

1. Must be fully recessed (the bulb and/or lens may not extend out of the can).
 2. Lights must be angled straight down.
 3. Lights may not exceed forty (40) watts or equivalent output.
 4. One (1) light temperature must be used for all lights, which must be between 2700K and 3000K to produce soft warm white illumination.
 5. Lights must be static. Lights which flash or pulse are strictly prohibited.
 6. Soffit/eve-mounted accent light cans and trim must match the color of the soffit/eve to which it is installed.
 7. Lights may not be mounted in a way or installed in locations which will allow them to shine onto and/or be a nuisance to neighboring properties.
- (d)** Exterior illumination of architectural features such as private walkway accent walls, entries, chimneys and landscape features is encouraged. A sconce light is preferred. Ground lighting or decorative fixtures shall be of high-quality materials and workmanship and be in scale and style with the residence.
- (e)** All exterior lighting, including LED lights must be of soft, warm white lighting.
- (f)** Sodium vapor lights, except for subdivision street lights, are prohibited.
- (g)** Mercury vapor lights, when used for special landscape lighting affect, (hung in trees as up and down lights) are permissible with ARC approval.
- (h)** Incandescent, low voltage incandescent, metal halide, quartz and natural gas lights are acceptable.
- (i)** Colored lighting of any sort is prohibited as is the use of fluorescent and neon lighting and colored lenses. Only during the holiday season will such lighting be permitted. Conduits and wiring shall remain concealed from view of the neighboring lots and all public views.
- (j)** All wiring for exterior lighting shall be underground.

- (k) Pathway lighting and landscape lighting is encouraged, but shall not be installed forward of the private walkway accent wall. Such lighting shall be inconspicuous. Pathway lighting along the public sidewalk and/or driveway is prohibited.
- (l) Lights (except those operating on 12 volts or less) may not be located within five (5') feet of a side property line or ten (10') feet of a rear property line. Lights shall be set back a minimum of ten (10') feet from the back of curb.
- (m) Decorative lighting fixtures shall be an integral and compatible part of the architecture of the dwelling. Light fixtures and their supports shall be of materials and colors of muted earth tones in the brown, gray, and green ranges are preferred. White fixtures and supports are acceptable only if they are compatible with the architectural style of the dwelling.
- (n) Proposed walkway lighting shall be inconspicuous and of a bollard or dome light design. The lamp may be:
 - Incandescent (100w maximum)
 - Quartz (75w maximum)
 - Metal Halide (75w maximum)
 - Fluorescent (25w maximum)
 - LED (Maximum 100w Incandescent equivalent)
- (o) Low level directional lighting along private walkways are encouraged.
- (p) All light fixtures and their locations shall be submitted (noted on the plans).

E. Antennas

Television antennas on roofs shall be avoided. It is preferable that antennas be placed within the attic space of a home or that the resident makes use of cable services. If placed outside, the antenna shall not encroach on neighboring private or public property. Antennas, satellite dishes, and radio towers shall be located in the least conspicuous location while still allowing for satisfactory reception. If multiple locations will provide satisfactory reception, the least conspicuous location must be used. If the antenna is placed on the site, it is suggested that the smallest antenna possible be used to avoid attention. Radio towers are prohibited. All cabling shall be concealed.

F. Energy Conservation

Minimize large glass areas on south and west sides of the home. Where windows are necessary, provide roof overhangs, porches, trellises, louvered windows, etc. to minimize direct heat gain.

IV. FENCING

4.1 General

This chapter outlines required fencing locations and types.

4.2 Fence Responsibility

Neighborhood fencing as outlined and illustrated in these guidelines will be the responsibility of each builder as they develop lots.

4.3 Fence Types & Requirements

Both metal and wood fencing will be used. These fence types are detailed below. All wood fence hardware connections are to be screw or ring shank nails, on a straight-line guide. No used material is allowed. Fences are to be kept in good repair. Painting, sealing or staining of fences is prohibited.

A. Wood Fence

All wood fences shall be six (6') foot solid, double-sided, capped, trimmed and include a rot board. No exposed ends will be permitted and the fence end must match the profile of the fence. Builder must install both sides of fence at the time of initial fence construction. The use of RightWood fence products is not allowed. The bottom of pickets shall be parallel and flush to the rot board.

(Reference Exhibits: "D1 & D2")

B. Metal Fence

All metal fencing will be of a manufactured product that uses pre-galvanized steel with a zinc phosphate primer coating and a topcoat paint finish. All mounting hardware will be of a bracket design. All metal fencing will be of a design that allows it to easily accommodate changes in elevation by use of a rackable system.

All metal fencing will have a flush mount bottom rail. All metal fencing will have a minimum 15-year manufacturer warranty. Tube steel fence shall be provided by Fortress Fence Products or Ameristar Fences and meet or exceed the specifications of the V2 FT/FB2 Commercial Fence (flat top, flat bottom) as provided by Fortress Fence Products.

(Reference Exhibit: "D3")

C. Developer Installed Brick Thinwall and Fencconcrete

Some lots, generally those backing or siding thoroughfares, collector streets and/or Section boulevard entrances, will have a Developer installed brick thinwall.

(Reference "Section VIII. - Section Fencing & Driveway Layouts")

(Reference Exhibits: "D4-A, D4-B & D4-C")

4.4 Fence Locations

A. Front Fences

Front fences shall be set back, a minimum of ten (10') feet and maximum of fifteen (15') feet, from front corner face of the house unless there are conflicts with windows or other architectural elements of the house.

B. Side Fences (Interior)

Side fences along interior property lines will be on the property line. Side interior fences more than ten

(10') feet long require a planting buffer.

C. Side Fence (Street Side – Corner Lot)

At the street side of corner lots, a minimum side fence setback of three (3') feet from the property line.

(Reference "Section V." for more detailed information on landscape requirements).

On all lots with detached garages, a breezeway fence is required between the detached garage and the home. This fence shall be a minimum of four (4') feet in height and a maximum of six (6') feet and shall be constructed of wood, wrought iron or brick depending on location. Detached garages on Corner Lots (when the breezeway/driveway is facing the street) shall have a four (4') foot masonry fence to match the masonry of the house with optional wrought iron up to two (2') feet attached to the masonry, for a maximum total height of six (6') feet.

For detached garages on Interior Lots, the breezeway fence can also be constructed of wood, and the gate shall be of the same material. If constructed of brick, the brick color shall be the same as the home and the gate shall be made of wrought iron. The maximum height for a fence in this location is six (6') feet. These fences shall extend from the rear of the house parallel to the side property line extending to the rear property line.

(Reference the required fencing types and locations for typical lot scenarios in the exhibits noted below.)

D. Interior Lot – Typical

Note: Confirm specific fencing type in "Section VIII. - Section Fencing & Driveway Layouts".

(Reference Exhibit: "D5")

E. Corner Lot – Typical

Note: Confirm specific fencing type in "Section VIII. - Section Fencing & Driveway Layouts".

(Reference Exhibits: "D6 & D7")

F. Landscape Reserve – Typical

Note: Confirm specific fencing type in "Section VIII. - Section Fencing & Driveway Layouts".

(Reference Exhibit: "D8")

G. Lake Lot – Typical

Note: Confirm specific fencing type in "Section VIII. - Section Fencing & Driveway Layouts".

(Reference Exhibit: "D9")

H. Side Yard at Lake – Typical

Note: Confirm specific fencing type in "Section VIII. - Section Fencing & Driveway Layouts".

(Reference Exhibit: "D10")

I. Rear Yard at Greenbelt, Walking Trail, Park, Etc. – Typical

Note: Confirm specific fencing type in the "Section Fencing & Driveway Layouts".

(Reference Exhibit: "D11")

J. Grade Transition Fencing

All wood fences shall follow grade transitions. No “stair-stepping” will be permitted.

(Reference Exhibit: “D2”)

K. Angled Fence

Side or rear fences on corner lots that perpendicular to the lot behind them will be angled at a forty-five (45) degree angle to meet the front building line of the perpendicular lot.

(Reference Exhibit: “D7”)

L. Fences & Vegetation as Screening

Utility meters, A/C units, pool equipment or other equipment shall be fully screened from public view with fencing and/or landscape. If landscaping is used, it shall create a solid screen immediately when planted.

(1) Interior Lots

Buyer must install at least one native shrub at the front of the A/C Unit and or Pool Equipment. The shrub must be at least half the height of the tallest-unit it is screening, and must be full, fast growing, hardy and drought resistant. Vegetation cannot be split/torn into multiple pieces. If a shrub and or other vegetation item are split/torn into pieces to plant in multiple areas, those plants will not be counted towards meeting the landscape requirements and their replacement may be requested at Final Inspection.

(2) Corner Lots

Buyer must install at least one native shrub at the front of the A/C Unit and or Pool Equipment. One additional shrub must be installed on the street facing side of each A/C Unit. Pool Equipment, depending on the size of the cluster, may require the installation of additional shrubs to create adequate side screening. All shrubs must be at least half the height of the tallest unit it is screening and must be full, fast growing, hardy and drought resistant.

M. Other Fence Types

The ARC will consider other fence types only where there are special conditions exist. Diagonal and horizontal fencing as well as chain link will never be permitted.

N. Submission and Approval

The ARC shall approve all fences prior to installation. The Builder shall clearly identify on each site submission, the fence type being proposed on all sides of the lot, as a confirmation of correct interpretation of the information on the Neighborhood Diagrams in the Appendix.

4.5 Fencing Diagrams

(Please see “Section VIII. - Section Fencing & Driveway Layouts”.)

4.6 Gates

A. Front Fence Gates

Gates will be allowed on front fences.

B. Side Fence Gates

Gates on side fences are prohibited.

C. Rear Fence Gates

Gates on rear fences will be considered on a case-by-case basis and only on lots which back to an amenity.

V. LANDSCAPE

5.1 General

This section outlines the standards for creating an attractive and functional landscape environment that enhances the architecture of the houses, provides a canopy along streets, buffers unwanted views and provides color, texture and visual interest.

5.2 Landscape Approach

All yards shall be landscaped with a minimum combination of trees, shrubs, ground covers and grass as shown in the planting charts and exhibits. Front yard trees and corner side yard trees are to be container grown or machine dug. The total front yard area covered by sod must not exceed more than seventy (70%) percent.

Planting beds are to be curvilinear with the shrubs massed in tiers. Smaller shrubs and ground cover are to be placed in the front of the bed. Larger shrubs shall be placed in the rear of the bed. Groupings of shrubs of the same species provide a substantial look. Landscape beds are not permitted along the public sidewalk.

Care shall be taken when planting large trees and shrubs near the foundation. Large trees and shrubs shall be planted no closer to the foundation than two (2) times the diameter of the root ball of a mature plant.

Radius beds shall be placed eight (8') feet minimum from the house. Widths of the beds shall vary. Planting beds, in addition to foundation plants, shall extend toward the front property line to offer a lush appearance to the community. Mulch all planting beds with at least two (2") inches deep shredded pine or hardwood mulch. Other materials to be used in place of mulch will be submitted to the ARC for approval.

Gravel and rock may be used at drip line of house, but is not permitted for use or substitution for shrubs, ground cover, and mulch or grass lawns. Specimen boulders may be permitted upon review and approval of the plan by the ARC.

5.3 Irrigation

Certain areas of each residential lot are required to have irrigation. Sprinkler heads shall be located to effectively and evenly water intended area with one-hundred (100%) percent coverage while minimizing overthrow onto pavement, private walks, public sidewalks, etc.

A. Front Yards

All front yards and areas forward of the front fence are required to be fully irrigated.

B. Side Yards

All side yards on corner lots, amenity lots or otherwise designated lots must be fully irrigated.

C. Rear Yards

Rear yards, which have rear or side metal fencing or any back yards which back or side an amenity, or otherwise designated lots must be fully irrigated.

Builders shall instruct the homeowners in the operation of the system. Care shall be taken to avoid irrigation spray and runoff on adjacent property. All irrigation systems shall be designed and installed by a licensed irrigator in the state of Texas and be equipped with a backflow prevention device as mandated by appropriate local code.

5.4 Boulders/Rocks in the Right-of-Way

Boulders/Rocks located in the right-of-way are a violation of Harris County policy and are not allowed.

5.5 Landscaping Components

These guidelines address the following areas: street, front yard, side yard for corner lots and in some cases, rear yard landscaping.

5.6 Yard Zone Definitions

(Reference Exhibit: "B1")

5.7 Front Yard Landscape

The standards for front yard landscaping are related to lot frontage. Refer to the *"Residential Plant List"* and Exhibits referenced in this section for more detailed requirements.

Front yard landscaping shall be done in such a manner to provide a colorful and complimentary foreground to the residence. Avoid placing large trees and plants in front of significant architectural features. Avoid shade trees planted exactly in the center of the yard. Front yard landscaping shall be used to screen driveways and large blank facades of the residence.

Avoid planting trees and/or large shrubs in close proximity to the address plaque to maintain a clear view corridor from a majority of the street.

A minimum of ten (10%) percent of shrubs shall be placed in the front ten (10') feet of the lot to compliment the right of way plantings and as terrace wall enhancements.

A. Lots 50' & Less – Typical

(Reference Exhibit: "B2")

B. Lots 55' - 65' – Typical

(Reference Exhibit: "B3")

C. Lots 70' - 80' – Typical

(Reference Exhibit: "B4")

D. Lots 100' & Greater – Typical

(Reference Exhibit: "B5")

5.8 Side Yard Landscape - Corner Lot

The street side yard of corner lots shall have plant material to soften long walls or fences. Fences shall be setback from the side property (right-of-way) line to allow for a landscape buffer. Refer to the *"Residential Plant List"* and Exhibits referenced in this section for more detailed requirements.

A thirty-five (35') by thirty-five (35') foot sight distance triangle shall be maintained at corners. Positioning of the trees and shrubs shall also not impede pedestrian access on the public sidewalk.

A. Side Yard, Corner Lot - Front Loaded – Typical

(Reference Exhibit: "B7")

B. Side Yard at Lake – Typical

(Reference Exhibit: "B8")

C. Side Yard at Greenbelt – Typical

(Reference Exhibit: "B9")

5.9 Rear Yard Landscape

Metal fencing is required on lots with public views, and those adjacent to a lake, greenbelt, walking trail, park, or common area (*Please see "Section Fencing & Driveway Layouts".*) The Builder will be required to provide landscape planting in the rear yard on these lots.

A. Rear Yard at Lake – Typical

(*Reference Exhibit: "B10"*)

B. Rear Yard at Greenbelt, Walking Trail, Park, Etc. – Typical

(*Reference Exhibit: "B11"*)

5.10 Plant Quantity Requirements

A. Sod

Solid sodding with Celebration Bermuda is required on all portions of the lot and within the right-of-way. This includes front, side, rear yards, and parkway areas between the curb. Lawns may be "over seeded" with rye grass (maintained to two and one half (2 ½") inch height).

B. Gravel & Rock

Neither gravel nor rock is permitted for ground cover unless used for drainage swales, in which case the gravel or rock may not extend any closer than thirty-six (36") inches from the back of curb. If used on the side yard of a corner lot the gravel or rock may not exceed past the side screening planter bed.

C. Plant Bed Edging

Plant bed edging is not required. If edging is installed, it must be in keeping with the architecture and materials of the residence. Scalloped concrete borders, bricks, plastic edging, and landscape timbers etc., are not permitted. Plant bed edging requirements are not limited to those listed in these Guidelines. Plant bed edging materials and construction design must be approved in writing by the ARC prior to installation.

D. Plant Material

A list of plant material considered to be appropriate for use in the landscape planting is available in the "*Residential Plant List*". Other plant material may be used if approved by the ARC, but priority shall be given to plants from this palette. The Builder is encouraged to use a blend of the suggested plant material throughout the community.

E. Residential Plant List

(*Reference Exhibit: "B12"*)

5.11 Energy Conservation

The use of shade trees and landscaping in lieu of concrete patios or drives near windows shall be used to reduce radiant heat gain. Landscaping shall be used extensively near windows and doors with deciduous shade trees and shrubs to provide a shield (shade) from the sun in the summer, but still allow the warmth of the sun to permeate in the winter.

5.12 Tree Protection and Preservation

Fences or barricades shall be placed around dripline (outward extent of tree canopy) of trees to prevent storing of machinery or equipment which can cause soil compaction and mechanical damage. No materials or equipment of any sort may enter or be stored within the fenced protection area or dripline of the tree; potentially toxic materials such as solvents, paints, gasoline or oil, etc., shall not be poured on the ground near the dripline of the trees.

- A.** There shall be no parking of vehicles or equipment under existing tree canopies.
- B.** Excessive pedestrian traffic shall not occur within dripline of trees. Care shall be taken when working in the vicinity of trees in order to prevent damage to trunks, branches, and foliage.
- C.** Soil shall not be excavated, spread, spoiled, or otherwise disposed of within the dripline of trees.
- D.** Trash fires are prohibited.
- E.** Trenching or boring near protected trees shall be avoided when possible. When necessary, care shall be taken to avoid damaging the tree's root system by hand trenching.
- F.** Placement of utilities within the dripline is detrimental to chances of survival on a developed Lot. Where keeping utility lines from within tree canopies is not possible, care shall be taken to protect root system as much as possible.
- G.** In close areas, where fencing to dripline is not possible, protect trunk by strapping (not nailing) a continuous shield of wood two inches by four inches by five feet (2"x 4"x 5') around the trunk and laying plywood on the ground in dripline of tree to prevent compaction of soil by trucks or machinery. No nails, bolts, ropes, or guy wires shall be attached to any trees.
- H.** Prune trees horizontally using accepted methods to compensate for any loss of root system.
- I.** Every effort shall be made to preserve existing trees by adjusting fence lines to weave among, jog around, or about to trees or stands of trees. No part of a fence may attach to a tree. No tree having a diameter greater than six (6") inches measured two (2') feet above natural grade may be removed for installation of fencing.

VI. PROCEDURES & SUBMISSIONS

6.1 General

The process of submitting plans, specifications and samples to the Bridgeland Architectural Review Committee (“ARC.”) is explained in this section. This process is intended as an instrument for ensuring that builders maintain uniform conformance to the guidelines, which have been established to create a new town consistent with the Bridgeland Mission Statement. Within the stated time-period for review, a clear and direct statement as to acceptability of construction plans will be made to builders who make submissions in accordance with the Standards.

The builder is solely responsible and liable for following the requirements of these Standards regardless of whether detail(s) of items are noted/called out on reviews/documentation including, but not limited to plans, permits, applications and inspections.

6.2 Scope of This Document

All new construction, subsequent construction, remodeling with exterior exposure, expansion, and demolition of structures within Bridgeland shall be reviewed and approved by the ARC, prior to commencement of any on-site building or construction activity. The ARC may consider any and all exterior elements of design including, but not limited to, size, massing, architectural style, colors, materials, harmony of design and other factors that, in the opinion of the ARC, affect the appearance of the improvement(s) and/or their compatibility with surrounding development.

This document specifically applies to the activities of Builders constructing new homes on lots on which there are no existing structures. A separate yet similar document will govern subsequent activities by homeowners or builders on lots once the initial construction activities have been completed.

6.3 Procedure

The review process begins when a Builder submits an online application including a set of plans, drawings, specifications and other required information to the ARC for processing. Submissions shall be made using the website below:

www.KenAnderson.com

Office: 281-367-5430

6.4 Required Submission Information

The builder is required to submit the following information to be reviewed by the ARC.

A. Architectural

- (1) Floor plans and (all) exterior elevations.
- (2) Outline specifications with materials/colors list clearly referenced to location.
- (3) Statement of House Square Footage. Note that ALL air-conditioned interior space, including, but not limited to, granny flats, shall be measured from interior stud to interior stud and be included in the house square footage.

B. Site

Plot plan drawing including the following information:

- (1) Village Name, Neighborhood Name, Section Number, Block Number, Lot Number.
- (2) Right of way, minimum setbacks & easements.

- (3) Actual footprint of house and garage, with dimensions of main elements from property line
- (4) Driveway, patios, walls and any other flatwork, fully dimensioned
- (5) Utility service locations
- (6) Total area of all footprint areas of impervious cover including house and garage footprint
- (7) Location, height and material of each exterior fence or wall
- (8) Any proposed freestanding exterior lighting, including fixture cuts including locations, mounting heights and manufacturer's catalog photographs of proposed fixtures.
- (9) Any temporary construction facilities such as trailers, storage locations, fences, temporary signs, lights, model home parking lots, etc.

C. Master Plans

In order to provide the shortest turnaround time for reviews the following shall be required. When submitting Master Plans for review, builders will submit each elevation as a separate submission. Each Master Plan (elevation) submission shall only include the plans, elevation, option, etc. sheets that pertain to that particular Master Plan (elevation).

6.5 Quality of Submission Content

It is in the interest of both the Builders and the Developer that this process be a smooth and timely one. Towards that end, the approvals can be facilitated if complete and high-quality documentation is provided to the ARC. When an Application is received, it is reviewed for completeness. An Application that is not complete and/or not clearly readable will be returned with an explanation of the reasons for this action. A complete Application will be processed and reviewed by the ARC.

6.6 Submission Timing

Submissions to the ARC for approval may be made at any time. Responses will generally be made within seven (7) business days from receipt of a completed online application (including all applicable supporting and required documents in electronic format), however there is no time restriction and lack of response shall be deemed a rejection.

6.7 Submission Fees

Nominal fees may be established by the Developer in the future to help defray the expenses associated with the review of improvements. The fees are adjusted from time to time and are based on the complexity of the project proposed. A list of current fees can be obtained from the Developer's office.

6.8 ARC Action on Submittals

The approval process is intended to minimize hardship or undue delays, while facilitating the common goals of the Builders and the Developer. Every effort will be made to review and act upon applications as soon as possible after they are received.

Notice of Approval, Conditional Approval or Disapproval of each submission will be returned to the Applicant via email or other electronic means which the ARC deems appropriate. Construction may proceed immediately following receipt of written Final Building Permit Approval from the ARC.

6.9 Expiration of Permits

All approved or conditionally approved permits shall be exercised within one (1) year from the date of approval, or the permit shall be null and void.

6.10 Variances

Variances to these Standards may be granted by the ARC. Any variance granted will only be applicable to the specified site and conditions for which the variance was granted, only if it has been identified in writing on the submitted plan and specifically approved in writing by the ARC. Granting of such a variance will not modify or change any standards as they apply to other lots or conditions.

All variances shall be exercised within one (1) year from the date of approval, or the variance shall be null and void. Upon an application, which must be submitted in writing thirty (30) days prior to the expiration and for good cause, the ARC may grant an extension of time not to exceed one (1) year.

6.11 Appeals

Every aspect of a proposal is carefully weighed and most projects are approved. If a proposed submission is not approved by the ARC, the applicant may appeal the decision to the ARC in writing within ten (10) days of receipt of the ARC decision. Appeal can be made by addressing a letter to the ARC stating the decision being appealed and the specific objection to the decision. The ARC then hears and rules on appeal as promptly as possible. All decisions of the ARC are final.

6.12 Construction Timeline

Construction of dwellings, which have received prior written approval or conditional approval by the ARC, shall commence within one (1) year of the permit date and shall be completed within:

- Production Home – One (1) Year
- Custom Home – Two (2) Years

The ARC may grant an extension for construction on a case-by-case basis, but the request for an extension must be made at least thirty (30) business days prior to the conclusion of the completion deadlines noted above.

Failure to complete a home within the designated time period may result in a penalty or fine to be drawn from the builder's construction deposit and/or damage deposit.

6.13 Final Compliance Inspection Procedures, Penalties, and Variances

A representative of the ARC must inspect the improvements to verify that they have been constructed in conformance with the Covenants, the approved plans and these Development Standards. The Final Compliance Inspection represents a selected portion of these Development Standards; it should not be considered as a total approval of these Development Standards. Inspections conducted by Bridgeland, the ARC and/or Ken Anderson & Associates are aesthetically based only and in no way, include inspections pertaining to code compliance or to the integrity of the home and/or improvements. Builders are solely responsible and liable for ensuring that all construction and/or improvements meet or exceed all applicable codes, good building practices and comply with all local and federal regulations, laws, etc. Each builder is ultimately responsible to make sure every home is built to be in full compliance with these Development Standards.

A. Inspection Procedures and Penalties

(1) Request for Initial Final Compliance Inspection

Once a home is completed, each Builder is responsible for making a request to the ARC for a Final Compliance Inspection, using the online request services at www.KenAnderson.com. Request for a Final Compliance Inspection must be made at least seven (7) days before the home closes.

A final survey (including all fences, pools and other installed improvements) must be submitted to the ARC at the time the Final Compliance Inspection request if made. Anyone who fails to meet the

requirements will be subject to a five-hundred (\$500.00) dollar fine, which may be deducted from the Builder's construction deposit and/or damage deposit.

If the property does not pass its initial Final Compliance Inspection, the builder will have ten (10) working days to correct all items listed on the Final Compliance Inspection report. It is the builder's responsibility to request a re-inspection once the necessary corrections have been completed otherwise a re-inspection will be conducted automatically after the ten (10) working days have expired.

(2) 2nd Final Compliance Inspection (Re-Inspection)

If the property does not pass its 2nd Final Compliance Inspection, the builder will have ten (10) working days to correct all items listed on the Final Compliance Inspection report. It is the builder's responsibility to request a re-inspection once the necessary corrections have been completed otherwise a re-inspection will be conducted automatically after the ten (10) working days have expired.

(3) 3rd Final Compliance Inspection (Re-Inspection)

The property will be inspected one final time. If all outstanding items have not been corrected, the following will occur:

- The builder will be issued a Final Compliance Inspection verdict of "Closed Non-Compliant" and a copy will be sent to the Bridgeland HOA.
- All New Construction Submittals/Building Permits (starts) will be put on hold company-wide until all outstanding inspection items are brought into compliance.
- Responsibility for bringing all outstanding items into compliance will transferred from the builder to the Homeowner and resolution may be enforced through the HOA as a request to comply with the New Construction Development Standards.
- When necessary, the HOA will inform the Homeowners that the home was inspected multiple times to allow the builder to bring the outstanding items into compliance, and that it was the Builders responsibility to make sure that all construction requirements were met before the home closed.

6.14 Remedies

Additional remedies and enforcement rights exist under the Covenants. The ARC may file suit to obtain an injunction mandating compliance with the Covenants and the Standards. The ARC has the further right, after proper notice to the Owner, to go onto the property where a violation exists, fix or remove the violation, and collect any costs incurred from the Owner.

6.15 Changes in Review Process

The ARC reserves the right to alter the review process in order to ensure an adequate review of all submissions while reasonably accommodating the needs of Builders.

6.16 Governmental Regulations

The Covenants and these Development Standards are not intended to permit any action prohibited by applicable laws, rules, or regulations of any governmental authority. Where these Standards contain requirements in addition to or more restrictive than applicable governmental laws or regulations, the provisions of these Standards are binding and enforceable, and prevail over the requirements of such laws or regulations unless these Standards are expressly made unenforceable by law or judicial decisions.

6.17 Job Site Procedures

A. Trash Containment

All lots under construction are required to have two forms of trash receptacles (types A & B). They must be kept on site and maintained during the construction process.

(1) Type A

Refers to a trash bin that will be used to contain trash material that will most likely be wind-blown from the construction of the home. This material includes, but is not limited to shingles, insulation, a/c ducts, and mortar bags. Material such as interior trim and tile will also be placed in this trash bin.

The three (3) sided trash bin will have an eight foot by eight-foot (8' x 8') footprint and be made up of four foot by eight foot (4' x 8') (natural or black painted) solid wood material panels. The open side must always face the front of the house, away from the street.

Heavy material such as lumber and brick should be placed in a single pile on the lot under construction. Any additional small debris left over after trash pick-up should be placed in a trash bin. No random material should be left out around the house.

(2) Type B

Refers to a trash bin that will be used to contain trash from labor and trade personnel working on the job site (plates, cans, food trash, etc.). This trash bin will be a fifty-gallon plastic drum or similar product that functions in the same capacity. Daily clean up food trash is required in order to reduce the amount of trash that is blown into the streets and neighborhood.

Each builder is responsible for enforcing the daily clean-up of food trash and making sure that all construction trash around the house is contained.

B. Concrete Washout

All concrete washouts shall be wood formed and lined with tarp on a lot which the Builder owns. Additionally, concrete washouts should be located (whenever possible) on lots which have low traffic and/or visibility to the general public. Concrete washouts shall not be located on Corner Lots and shall have an erosion barrier installed and maintained solely by the Builder at all times.

C. Silt/Mud in Street

Each builder is responsible for ensuring that every lot under construction has a silt fence installed along the entire street facing portion of the lot and have at least two (2) foot returns at termination points. One (1), sixteen (16') foot maximum width access point may be utilized (generally the future driveway location), which must employ a proper erosion barrier, such as: rip-rap, wood chips, etc.

Unacceptable erosion barriers at access points include, but are not limited to: Curlex, sod, sand and back-cutting the dirt directly behind the curb. All erosion barriers must be maintained and any silt or mud that develops must be removed immediately whenever possible and no later than the end of construction hours for that day. Each builder is also responsible for repairing any silt fence that is damaged on an adjacent lot during construction. This also includes the removal of any dirt or mud that accumulates in the street from access to a home under construction via an adjacent lot.

D. Damage to Common Areas and/or Cul-de-Sac Island(s)

The builder is responsible for any damages incurred on the common areas and or cul-de-sacs sustained by their subcontractors or delivery trucks. This includes, but is not limited to ruts, planting damage, and or irrigation damage. The builder will either be asked to replace or repair the damaged material or be billed for any damages.

E. Lot Mowing

Each builder is responsible for ensuring that the lots they own are maintained and mowed on at least a monthly basis.

VII. EXHIBITS & DIAGRAMS

All exhibits & diagrams will be found on the pages that follow.

THIS PAGE INCLUDES ONLY STANDARD NOTES. FOR FULL DETAILS AND REQUIREMENTS REFERENCE APPLICABLE PORTIONS OF THESE RESIDENTIAL NEW CONSTRUCTION DEVELOPMENT STANDARDS.

PRIVATE WALKWAY ACCENT WALLS ("ACCENT WALLS") STANDARD NOTES:

1. PRIVATE WALKWAY ACCENT WALL - BRICK & STONE TO MATCH THE HOME'S ARCHITECTURE, MATERIAL & STACKING ORDER.
2. END OF STREET-FACING PORTION OF ACCENT WALL TO BE MINIMUM THREE (3') FEET FROM EDGE OF DRIVEWAY.
3. STREET-FACING FRONT OF PRIVATE WALKWAY ACCENT WALLS TO BE A MINIMUM OF ELEVEN TO THIRTEEN (11'-13') FEET OFF INTERNAL SIDE OF PUBLIC WALK UNLESS AT CUL-DE-SAC (9'-0" - 11'-0").

LANDSCAPE REQUIREMENT STANDARD NOTES:

1. FRONT YARD TO CONSIST OF A MINIMUM OF THIRTY (30%) PERCENT PLANTER BED COVERAGE. (SEE EXHIBIT "B1" FOR YARD ZONE DETAILS.)
2. PLANTING BED COVERAGE AREAS TO BE ORGANIC IN FORM.
3. PLANTER BED COVERAGE TO REQUIRE 2"-3" HARDWOOD MULCH. HARDWOOD MULCH COLOR TO BE BLACK OR DARK BROWN ONLY. NO RED MULCH IS PERMITTED.
4. PALM TREES ALLOWED ONLY IN REAR YARD AREAS.
5. REFERENCE LANDSCAPE REQUIREMENTS & EXHIBITS FOR SHADE TREE REQUIREMENTS.
6. REFERENCE LANDSCAPE REQUIREMENTS & EXHIBITS FOR ORNAMENTAL TREE REQUIREMENTS.
7. STREET-SIDE ELEVATION OF CORNER LOT HOMES TO REQUIRE CONTINUOUS SCREENING WITH EVERGREEN PLANTING IN PLANTER BED COVERAGE. TWO (2) SHADE TREES ARE REQUIRED THIS AREA.
8. LOW PLANTING ONLY IN FRONT OF PRIVATE WALKWAY ACCENT WALLS AND WITHIN THREE (3') FEET FROM EDGE OF DRIVEWAY. REFERENCE RECOMMENDED LOW PLANTING LIST.
9. EVERGREEN SCREENING PLANTS ARE TO BE PLACED IN FRONT OF A/C UNITS ON INTERIOR LOTS. FOR CORNER LOTS, ONE (1) SCREENING PLANT SHALL BE IN FRONT AND ONE (1) SCREENING PLANT ON SIDE OF EACH UNIT/EQUIPMENT.
10. EVERGREEN SCREENING PLANTS ARE TO BE AT LEAST HALF THE HEIGHT OF THE TALLEST A/C UNIT ONCE PLANTED.
11. A/C UNITS & POOL UNITS MUST BE COMPLETELY SCREENED FROM PUBLIC VIEWS.
12. TREES ARE TO BE PLACED WITHIN THREE (3') FOOT MINIMUM MULCH BED.
13. ORNAMENTAL & SHADE TREES SHALL NOT BE PLANTED WITHIN THREE (3') FEET OF EDGE OF DRIVEWAY AND NOT WITHIN FIVE (5') FEET OF PRIVATE WALKWAY ACCENT WALLS.
14. ALL FRONT YARDS & AMENITY SIDE & REAR YARDS TO REQUIRE FULL IRRIGATION.
15. ALL FRONT YARD TREES & SIDE & REAR YARD AMENITY LOT SHADE TREES TO REQUIRE BUBBLERS.

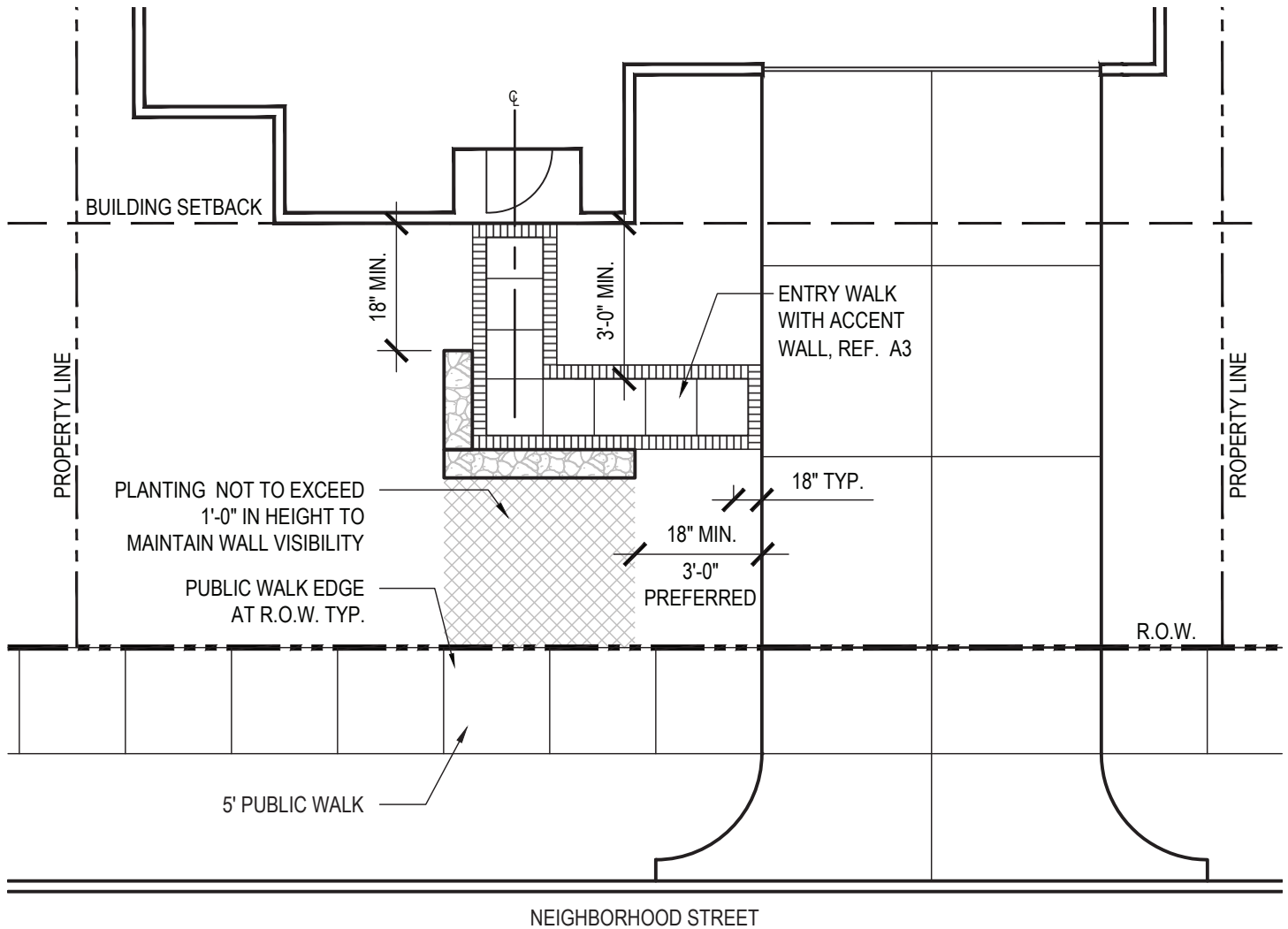

NOTES

1. REFERENCE CONCRETE WALK DETAIL FOR INFORMATION REGARDING LAYOUT AND WALK.
2. ACCENT WALL TO BE A MINIMUM OF TWO (2') FEET BEHIND PROPERTY LINE.
3. ACCENT WALL AND ENTRY WALK TO BE INCLUDED ON PLOT PLAN FOR APPROVAL.

PRIVATE WALKWAY & ACCENT WALL - ALTERNATIVE PLAN

SCALE: NTS

A2.2

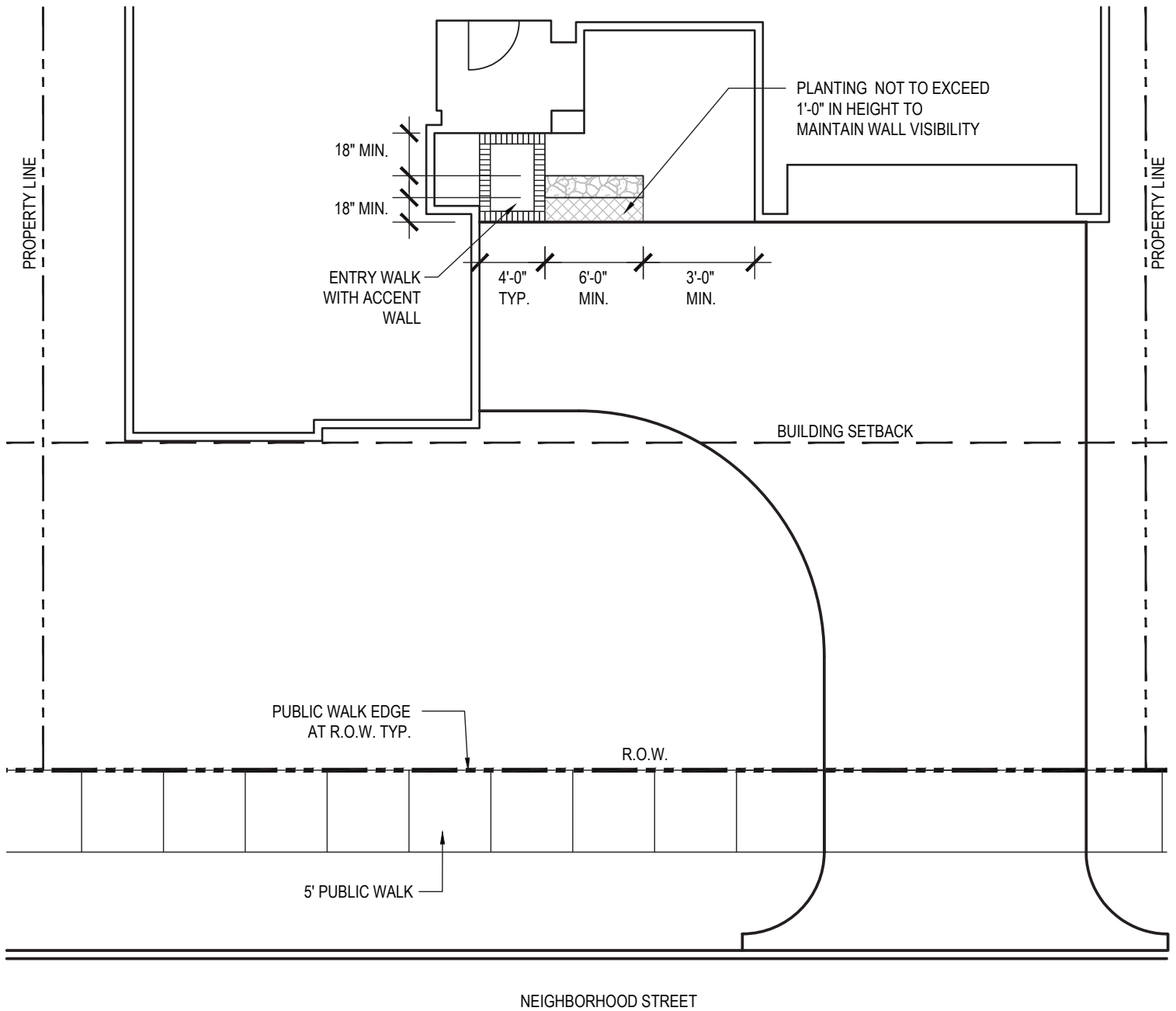

NOTES

1. REFERENCE CONCRETE WALK DETAIL FOR INFORMATION REGARDING LAYOUT AND WALK.
2. ACCENT WALL TO BE A MINIMUM OF TWO (2) FEET BEHIND PROPERTY LINE.
3. ACCENT WALL AND ENTRY WALK TO BE INCLUDED ON PLOT PLAN FOR APPROVAL.

PRIVATE WALKWAY & ACCENT WALL - TYPICAL PLAN (ENLARGEMENT)

SCALE: NTS

A3.1

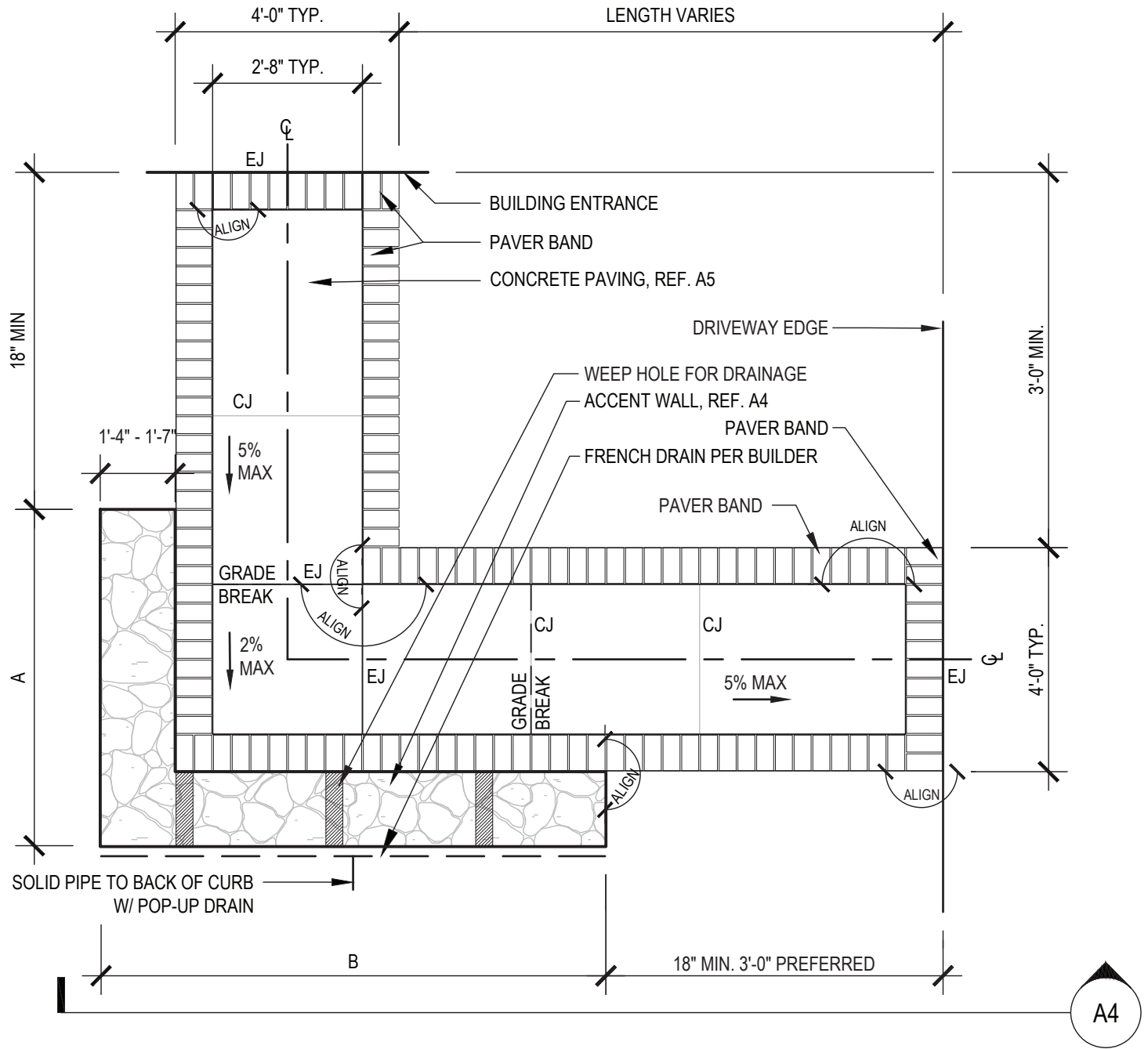

A4

NOTES

- MASONRY SPECIFICATION AND COURSING TO MATCH HOUSE.
- TYPICAL 2% MAX CROSS SLOPE ON ALL WALKS, MAX 5% LONGITUDINAL SLOPE.
- ENTRY WALK TO DRAIN TOWARDS DRIVEWAY.
- NO VEGETATION SHALL BLOCK THE FLOW OF WATER OFF OF WALKS, IMPEDE LOT DRAINAGE, OR BLOCK ADDRESS MARKER.
- FRONT YARD SHALL REQUIRE FULL IRRIGATION.
- SOD SHALL BE CELEBRATION BERMUDA.
- PLANTER BED COVERAGE TO REQUIRE 2"-3" OF HARDWOOD MULCH.
- CONTROL JOINTS AND MORTAR JOINTS TO ALIGN.
- ACCENT WALL TO BE MIN. 2'-0" FROM PROPERTY LINE.
- ACCENT WALL & ENTRY WALK TO BE INCLUDED ON PLOT PLAN FOR APPROVAL.

WALL DIMENSIONS		
LOT SIZE	WALL LENGTH (A)	WALL LENGTH (B)
50' OR LESS	6'	7'
55' - 65'	6'	9'
70' & 80'	6'	11'
100' OR GREATER	6'	14'
CUL-DE-SAC	6'	9'

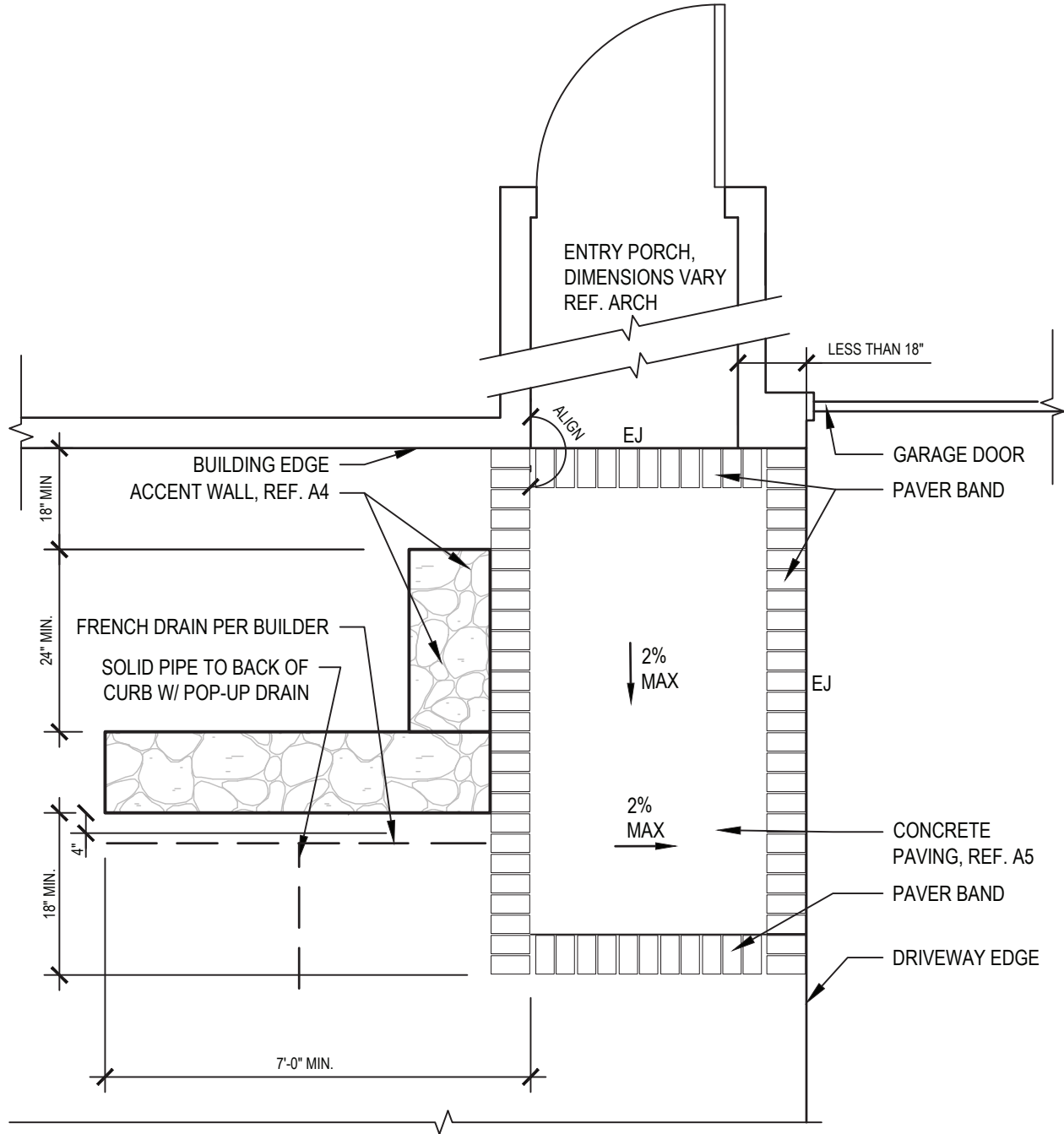

NOTES

1. MASONRY SPECIFICATION AND COURSING TO MATCH HOUSE.
2. TYPICAL 2% MAX CROSS SLOPE ON ALL WALKS, MAX 5% LONGITUDINAL SLOPE.
3. ENTRY WALK TO DRAIN TOWARDS DRIVEWAY.
4. NO VEGETATION SHALL BLOCK THE FLOW OF WATER OFF OF WALKS, IMPEDE LOT DRAINAGE, OR BLOCK ADDRESS MARKER.
5. FRONT YARD SHALL REQUIRE FULL IRRIGATION.
6. SOD SHALL BE CELEBRATION BERMUDA.
7. PLANTER BED COVERAGE TO REQUIRE 2"-3" OF HARDWOOD MULCH.
8. CONTROL JOINTS AND MORTAR JOINTS TO ALIGN.
9. ACCENT WALL TO BE MIN. 2'-0" FROM PROPERTY LINE.
10. ACCENT WALL & ENTRY WALK TO BE INCLUDED ON PLOT PLAN FOR APPROVAL.

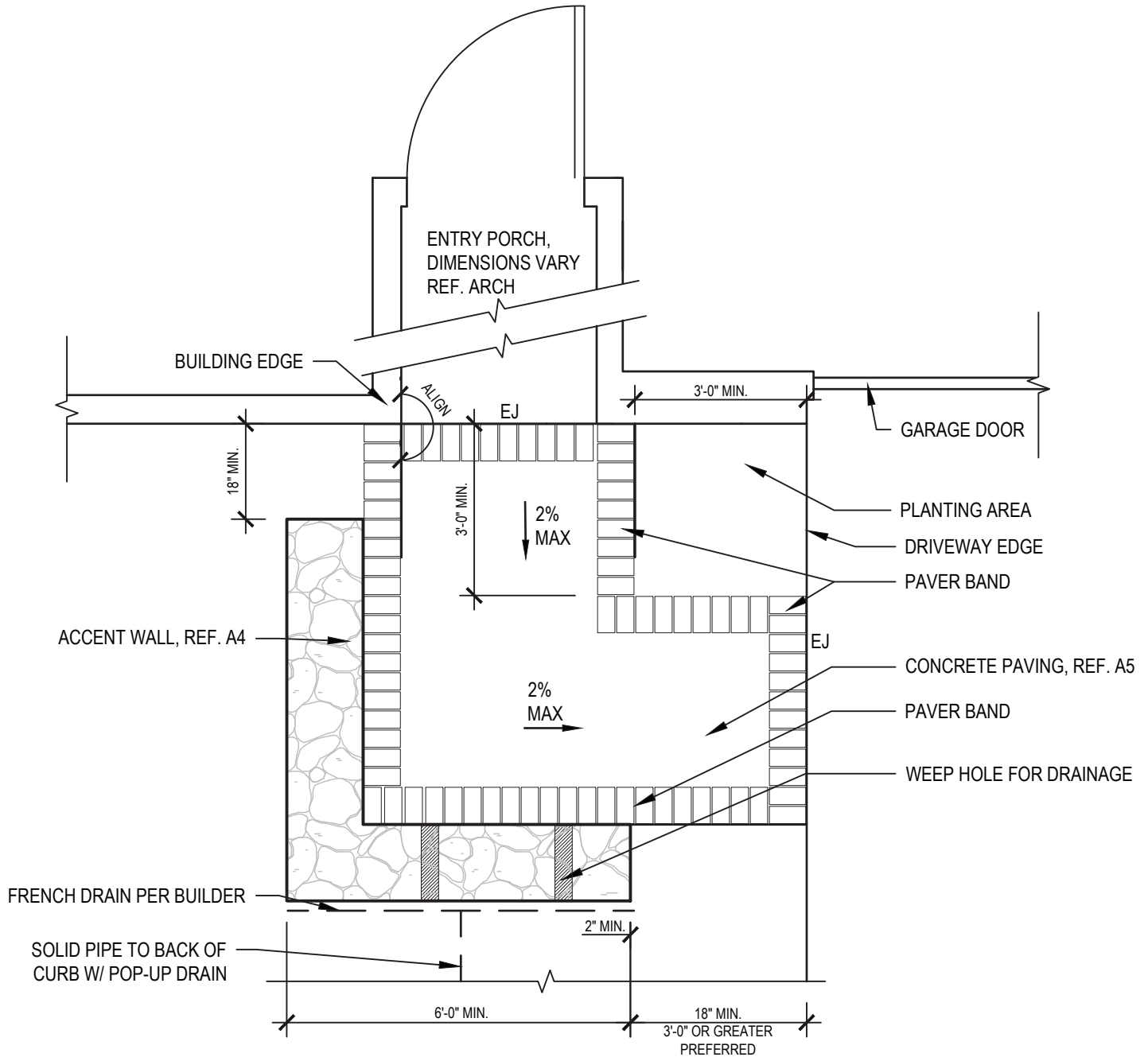

NOTES

1. MASONRY SPECIFICATION AND COURSING TO MATCH HOUSE.
2. TYPICAL 2% MAX CROSS SLOPE ON ALL WALKS, MAX 5% LONGITUDINAL SLOPE.
3. ENTRY WALK TO DRAIN TOWARDS DRIVEWAY.
4. NO VEGETATION SHALL BLOCK THE FLOW OF WATER OFF OF WALKS, IMPEDE LOT DRAINAGE, OR BLOCK ADDRESS MARKER.
5. FRONT YARD SHALL REQUIRE FULL IRRIGATION.
6. SOD SHALL BE CELEBRATION BERMUDA.
7. PLANTER BED COVERAGE TO REQUIRE 2"-3" OF HARDWOOD MULCH.
8. CONTROL JOINTS AND MORTAR JOINTS TO ALIGN.
9. ACCENT WALL TO BE MIN. 2'-0" FROM PROPERTY LINE.
10. ACCENT WALL & ENTRY WALK TO BE INCLUDED ON PLOT PLAN FOR APPROVAL.

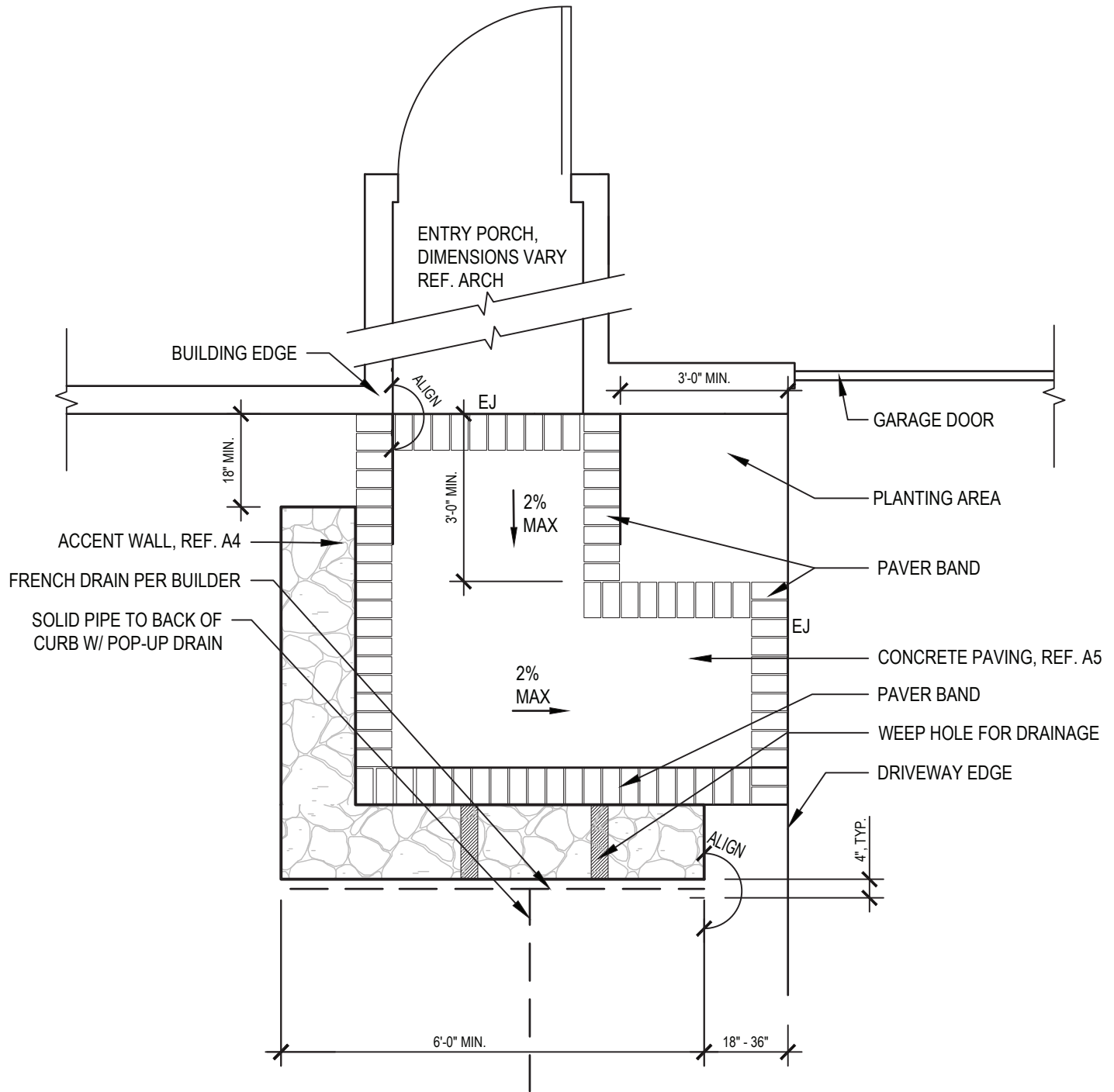

NOTES

1. MASONRY SPECIFICATION AND COURSING TO MATCH HOUSE.
2. TYPICAL 2% MAX CROSS SLOPE ON ALL WALKS, MAX 5% LONGITUDINAL SLOPE.
3. ENTRY WALK TO DRAIN TOWARDS DRIVEWAY.
4. NO VEGETATION SHALL BLOCK THE FLOW OF WATER OFF OF WALKS, IMPEDE LOT DRAINAGE, OR BLOCK ADDRESS MARKER.
5. FRONT YARD SHALL REQUIRE FULL IRRIGATION.
6. SOD SHALL BE CELEBRATION BERMUDA.
7. PLANTER BED COVERAGE TO REQUIRE 2"-3" OF HARDWOOD MULCH.
8. CONTROL JOINTS AND MORTAR JOINTS TO ALIGN.
9. ACCENT WALL TO BE MIN. 2'-0" FROM PROPERTY LINE.
10. ACCENT WALL & ENTRY WALK TO BE INCLUDED ON PLOT PLAN FOR APPROVAL.

PRIVATE WALKWAY & ACCENT WALL - TYPICAL ELEVATION

SCALE: NTS

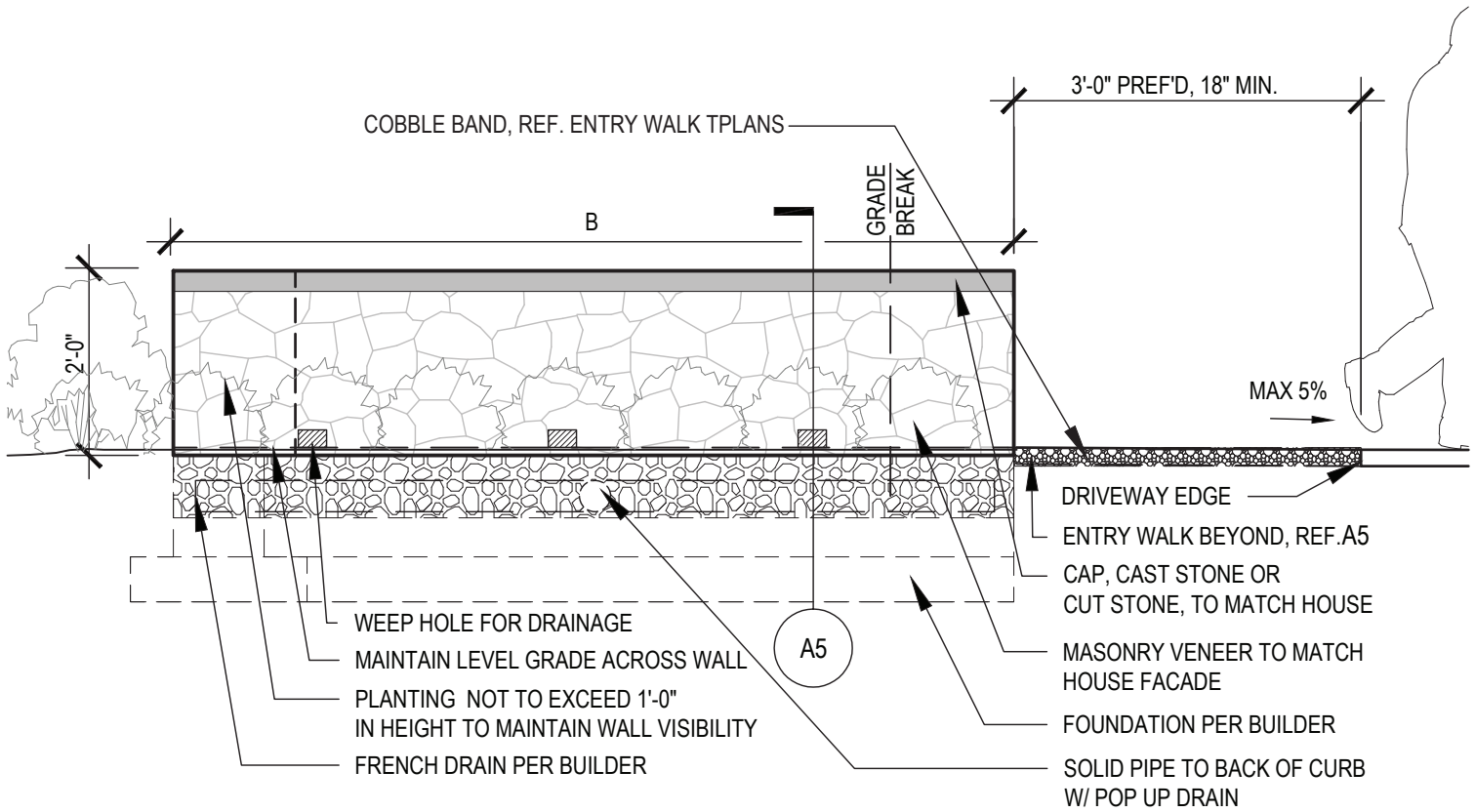

NOTES

1. MASONRY SPECIFICATION AND COURSING TO MATCH HOUSE.
2. TYPICAL 2% MAX CROSS SLOPE ON ALL WALKS, MAX 5% LONGITUDINAL SLOPE.
3. ENTRY WALK TO DRAIN TOWARDS DRIVEWAY.
4. NO VEGETATION SHALL BLOCK THE FLOW OF WATER OFF OF WALKS, IMPEDE LOT DRAINAGE, OR BLOCK ADDRESS MARKER.
5. FRONT YARD SHALL REQUIRE FULL IRRIGATION.
6. SOD SHALL BE CELEBRATION BERMUDA.
7. PLANTER BED COVERAGE TO REQUIRE 2"-3" OF HARDWOOD MULCH.
8. CONTROL JOINTS AND MORTAR JOINTS TO ALIGN.
9. ACCENT WALL TO BE MIN. 2'-0" FROM PROPERTY LINE.
10. ACCENT WALL & ENTRY WALK TO BE INCLUDED ON PLOT PLAN FOR APPROVAL.

WALL DIMENSIONS		
LOT SIZE	WALL LENGTH (A)	WALL LENGTH (B)
50' OR LESS	6'	7'
55' - 65'	6'	9'
70' & 80'	6'	11'
100' OR GREATER	6'	14'
CUL-DE-SAC	6'	9'

PRIVATE WALKWAY & ACCENT WALL - TYPICAL DETAIL

SCALE: NTS

A5

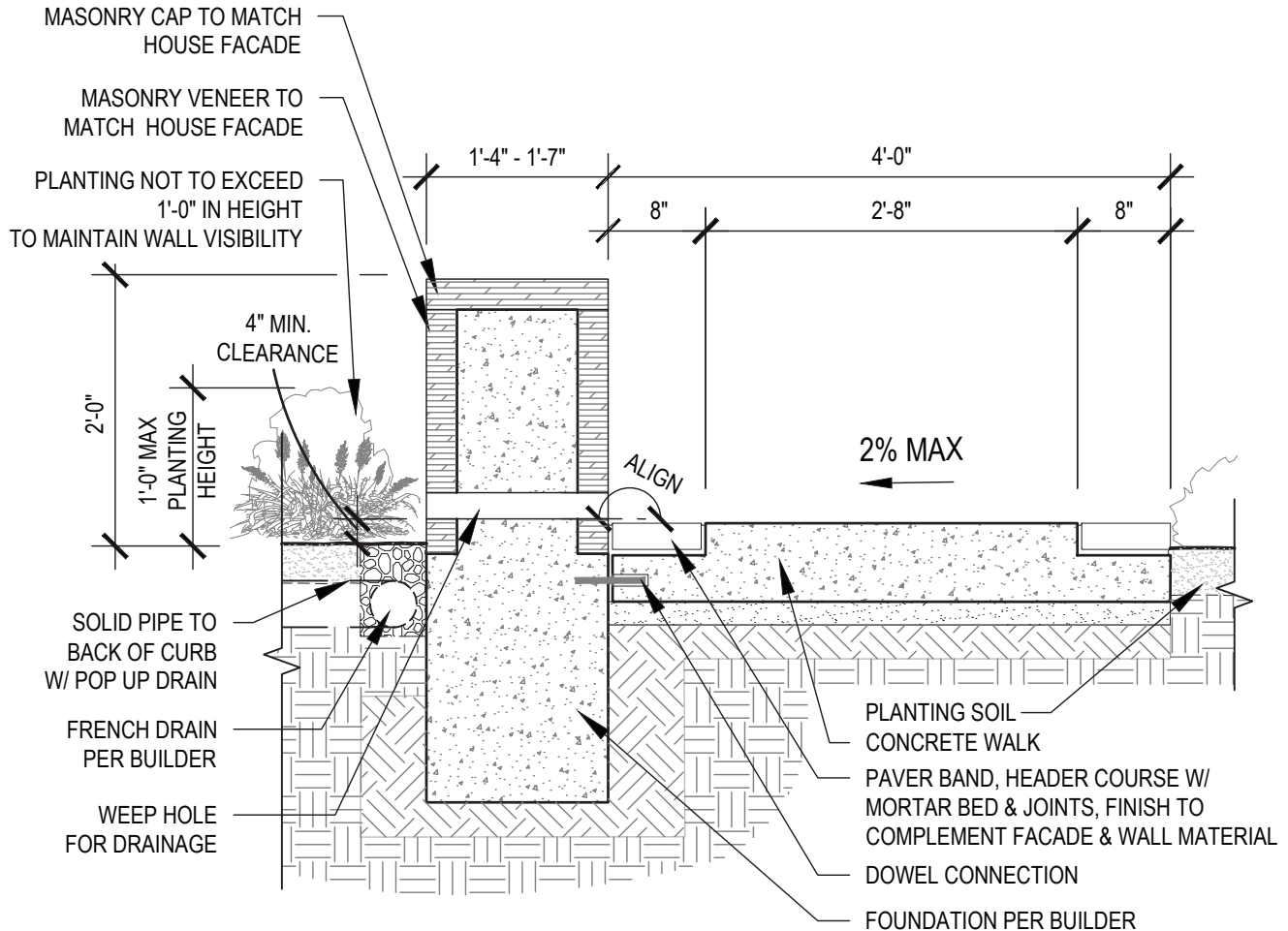

NOTES

1. MASONRY SPECIFICATION AND COURSING TO MATCH HOUSE.
2. TYPICAL 2% MAX CROSS SLOPE ON ALL WALKS, MAX 5% LONGITUDINAL SLOPE.
3. ENTRY WALK TO DRAIN TOWARDS DRIVEWAY.
4. NO VEGETATION SHALL BLOCK THE FLOW OF WATER OFF OF WALKS, IMPEDE LOT DRAINAGE, OR BLOCK ADDRESS MARKER.
5. FRONT YARD SHALL REQUIRE FULL IRRIGATION.
6. SOD SHALL BE CELEBRATION BERMUDA.
7. PLANTER BED COVERAGE TO REQUIRE 2"-3" OF HARDWOOD MULCH.
8. CONTROL JOINTS AND MORTAR JOINTS TO ALIGN.
9. ACCENT WALL TO BE MIN. 2'-0" FROM PROPERTY LINE.
10. ACCENT WALL & ENTRY WALK TO BE INCLUDED ON PLOT PLAN FOR APPROVAL.

WALL DIMENSIONS		
LOT SIZE	WALL LENGTH (A)	WALL LENGTH (B)
50' OR LESS	6'	7'
55' - 65'	6'	9'
70' & 80'	6'	11'
100' OR GREATER	6'	14'
CUL-DE-SAC	6'	9'

FRONT YARD GRADING - TYPICAL

SCALE: NTS

A6

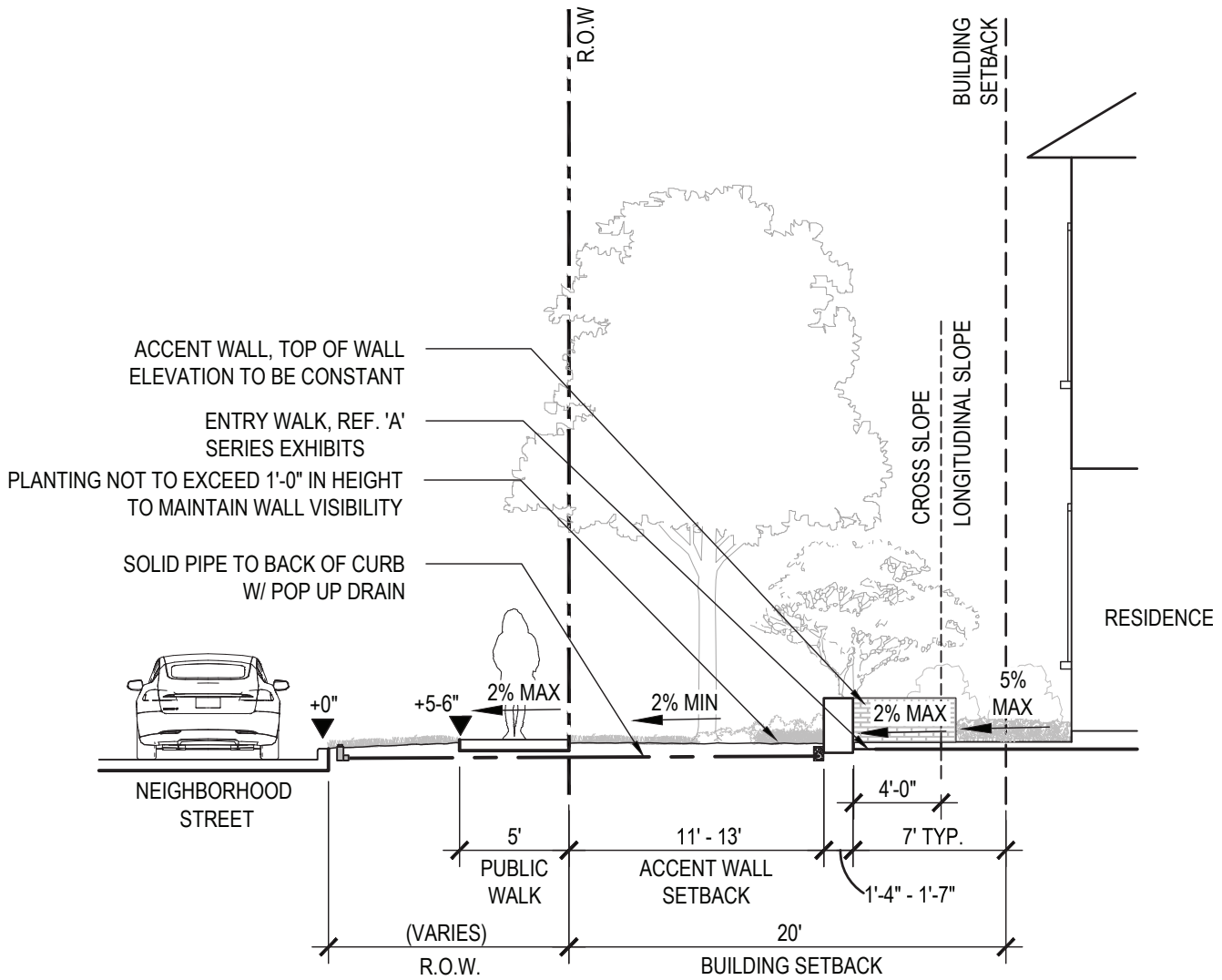

NOTES

1. MASONRY SPECIFICATION AND COURSING TO MATCH HOUSE.
2. TYPICAL 2% MAX CROSS SLOPE ON ALL WALKS, MAX 5% LONGITUDINAL SLOPE.
3. ENTRY WALK TO DRAIN TOWARDS DRIVEWAY.
4. NO VEGETATION SHALL BLOCK THE FLOW OF WATER OFF OF WALKS, IMPEDE LOT DRAINAGE, OR BLOCK ADDRESS MARKER.
5. FRONT YARD SHALL REQUIRE FULL IRRIGATION.
6. SOD SHALL BE CELEBRATION BERMUDA.
7. PLANTER BED COVERAGE TO REQUIRE 2"-3" OF HARDWOOD MULCH.
8. CONTROL JOINTS AND MORTAR JOINTS TO ALIGN.
9. ACCENT WALL TO BE MIN. 2'-0" FROM PROPERTY LINE.
10. ACCENT WALL & ENTRY WALK TO BE INCLUDED ON PLOT PLAN FOR APPROVAL.

EXPANSION & CONTROL JOINT LAYOUT - TYPICAL

SCALE: NTS

A8

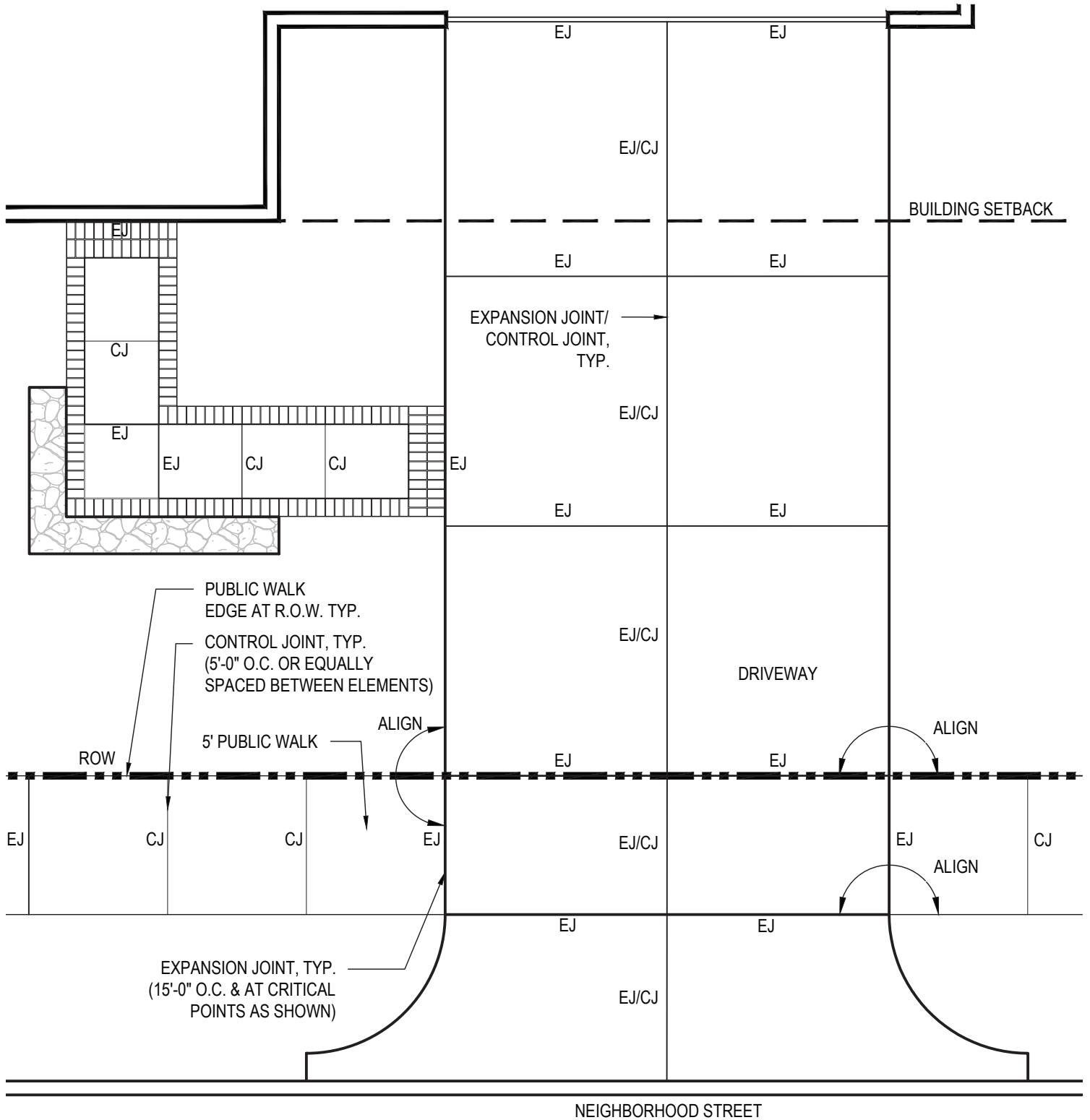

NOTES

1. REFERENCE CONCRETE WALK DETAIL FOR INFORMATION ABOUT JOINT LAYOUT.
2. PUBLIC WALK JOINTS 5'-0" O.C. TYP.
3. REFERENCE EXHIBIT "A2" FOR ENTRY WALK JOINT SPACING.
4. EXPANSION JOINTS 15'-0" O.C. & AT CRITICAL POINTS AS SHOWN.

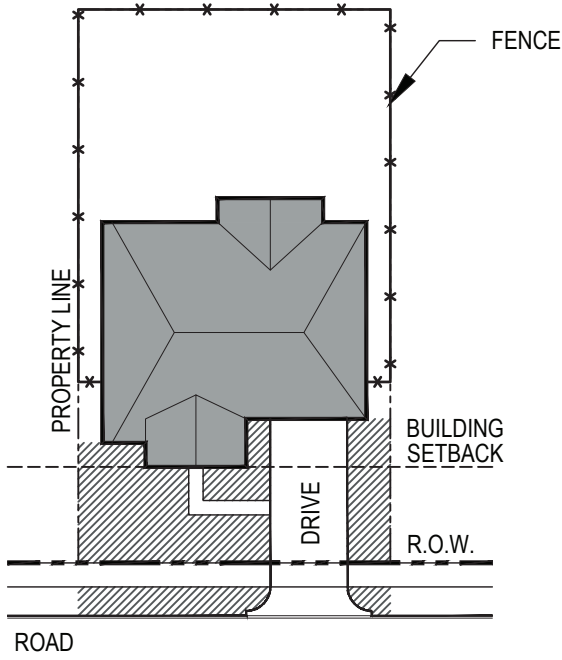

FRONT YARD

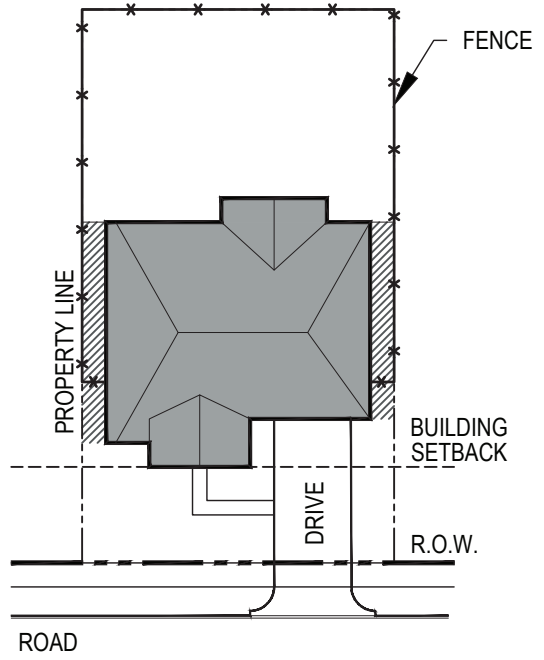

SIDE YARD

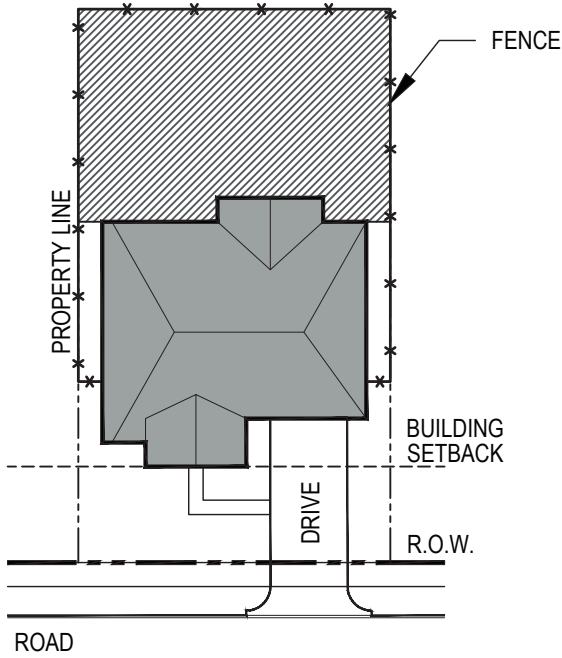

REAR YARD

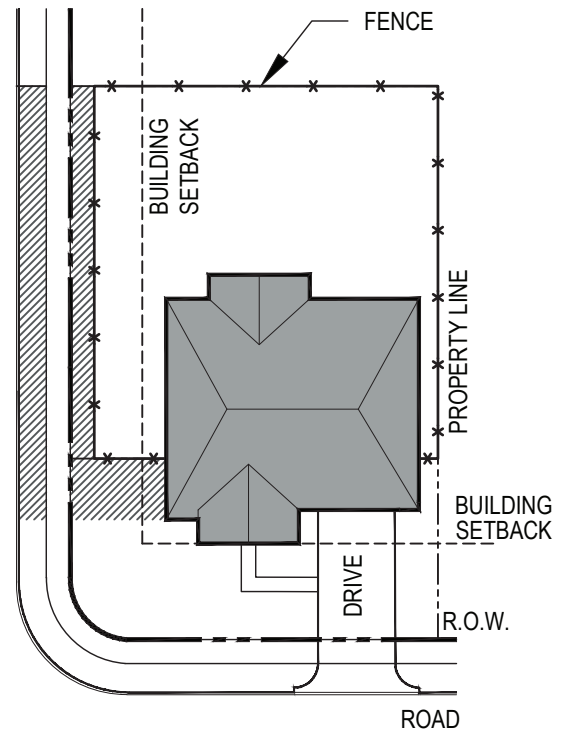

SIDE YARD
CORNER LOT, FRONT LOADED

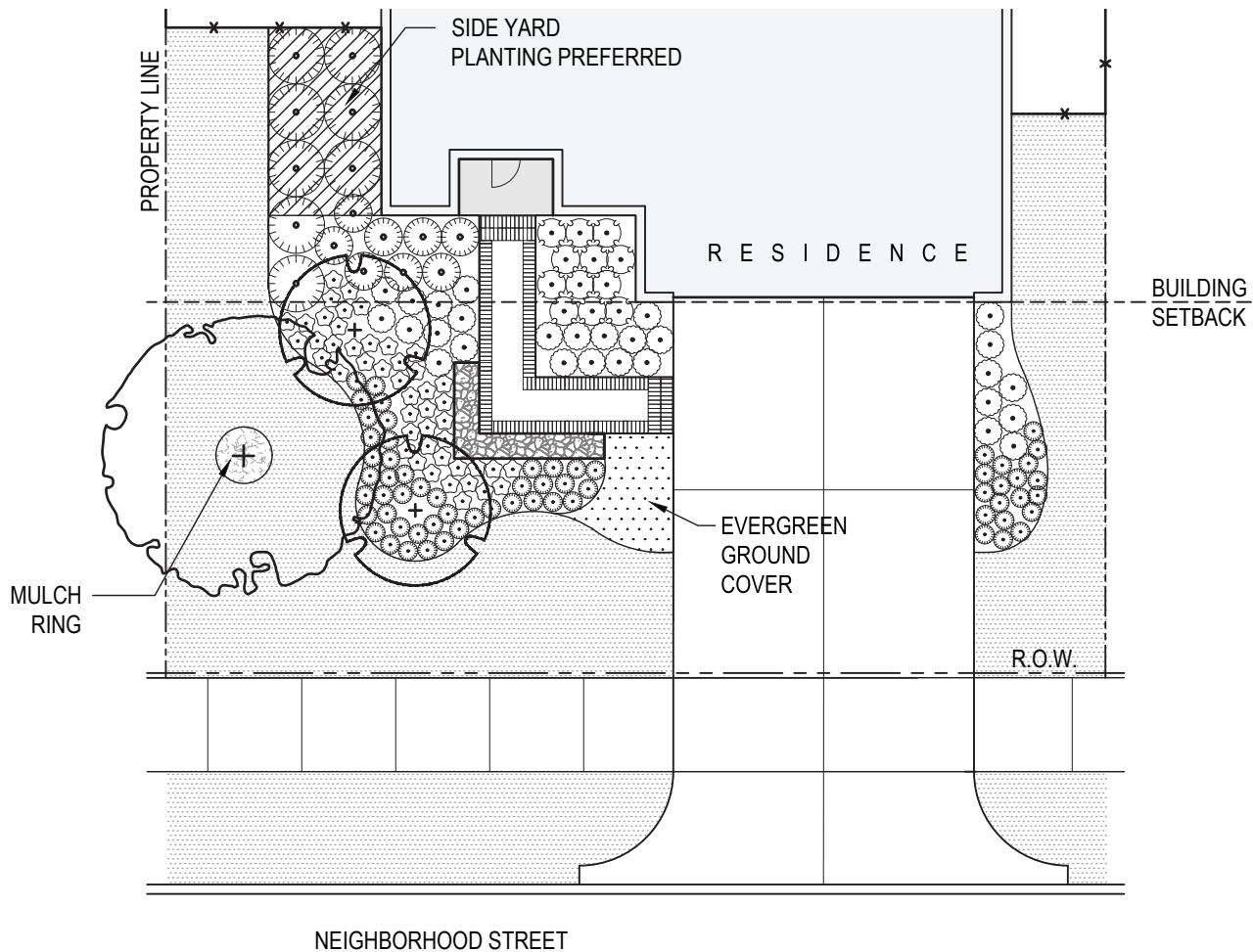

NOTES

1. REFERENCE LANDSCAPE REQUIREMENTS, APPROVED PLANTING LIST & FRONT ENTRY WALK STANDARD NOTES.
2. FRONT YARD SHALL REQUIRE FULL IRRIGATION.
3. SOD SHALL BE CELEBRATION BERMUDA.
4. PLANTER BED COVERAGE TO REQUIRE 2"-3" OF HARDWOOD MULCH.
5. NO VEGETATION SHALL BLOCK THE FLOW OF WATER OFF OF WALKS, IMPEDE LOT DRAINAGE, OR BLOCK ADDRESS MARKER.
6. TREE MULCH PER PLANTING SPECIFICATIONS.
7. PLANTING ON STREET SIDE OF ACCENT WALL NOT TO EXCEED 1'-0" IN HEIGHT.
8. PLANTER BED COVERAGE SHALL BE 30% OF THE FRONT YARD (INCLUDES SOFTSCAPE AREA FROM FACE OF RESIDENCE TO BACK OF CURB), REF EXHIBIT "B1": "TYPICAL ZONES - FRONT YARD, SIDE YARD & REAR YARD".
9. ALL LOTS TO RECEIVE REAR YARD SHADE TREES, REF. REAR YARD TREE REQUIREMENTS TABLE ON EXHIBITS "B10" & "B11".

50' LOT REQUIREMENTS		
SYMBOL	DESCRIPTION	QUANTITY
	FRONT YARD SHADE TREE(S)	1
	REAR YARD SHADE TREE(S)	1
	ORNAMENTAL TREE(S)	2
	EVERGREEN SCREENING	40%
	EVERGREEN GROUND COVER	10%
	PERENNIALS	25%
	ORNAMENTAL GRASSES	10%
	ORNAMENTAL SHRUBS	15%
	PLANTER BED COVERAGE	30%

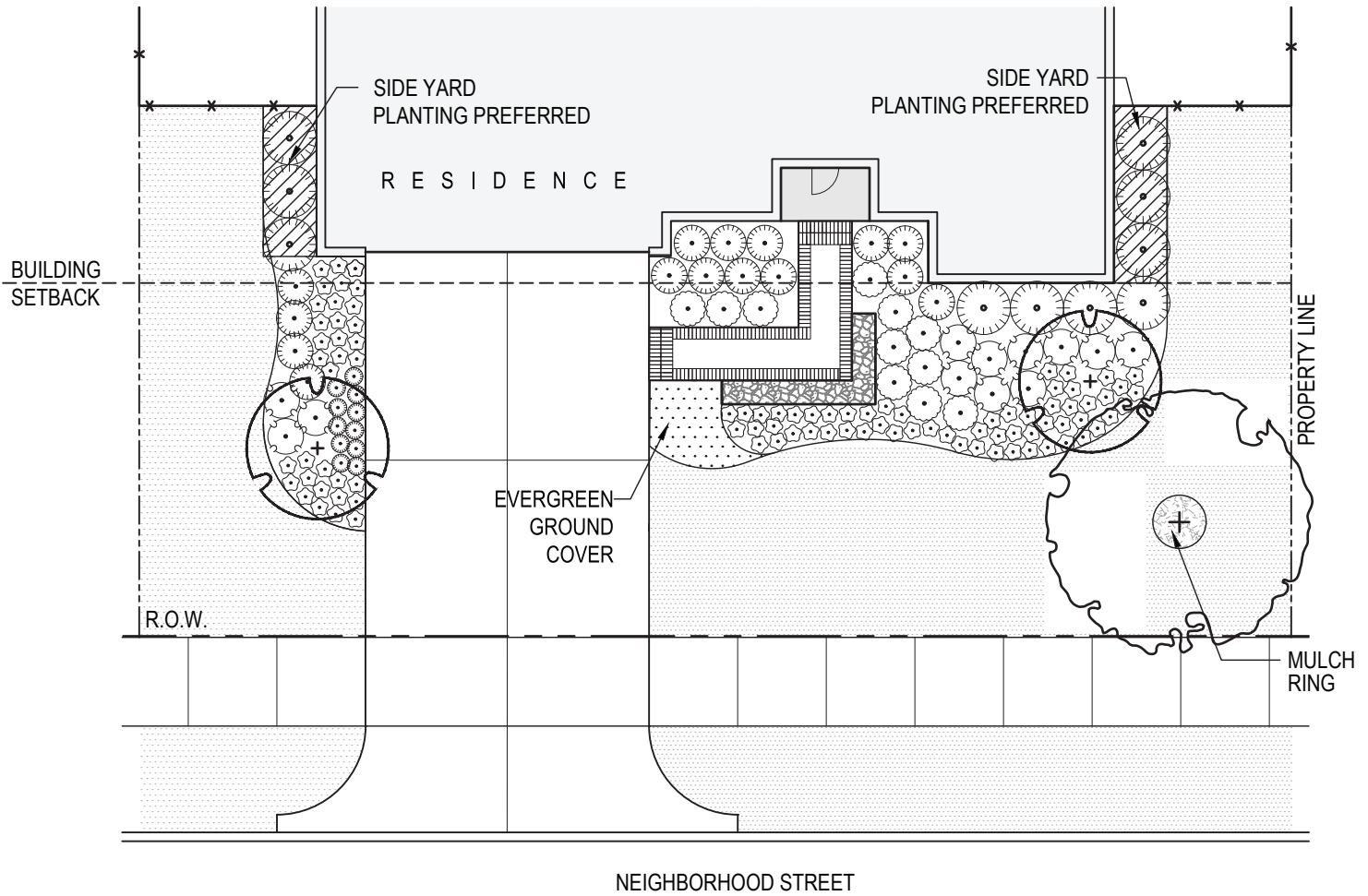

NOTES

1. REFERENCE LANDSCAPE REQUIREMENTS, APPROVED PLANTING LIST & FRONT ENTRY WALK STANDARD NOTES.
2. FRONT YARD SHALL REQUIRE FULL IRRIGATION.
3. SOD SHALL BE CELEBRATION BERMUDA.
4. PLANTER BED COVERAGE TO REQUIRE 2"-3" OF HARDWOOD MULCH.
5. NO VEGETATION SHALL BLOCK THE FLOW OF WATER OFF OF WALKS, IMPEDE LOT DRAINAGE, OR BLOCK ADDRESS MARKER.
6. TREE MULCH PER PLANTING SPECIFICATIONS.
7. PLANTING ON STREET SIDE OF ACCENT WALL NOT TO EXCEED 1'-0" IN HEIGHT.
8. PLANTER BED COVERAGE SHALL BE 30% OF THE FRONT YARD (INCLUDES SOFTSCAPE AREA FROM FACE OF RESIDENCE TO BACK OF CURB), REF EXHIBIT "B1": "TYPICAL ZONES - FRONT YARD, SIDE YARD & REAR YARD".
9. ALL LOTS TO RECEIVE REAR YARD SHADE TREES, REF. REAR YARD TREE REQUIREMENTS TABLE ON EXHIBITS "B10" & "B11".

55' & 65' LOT REQUIREMENTS		
SYMBOL	DESCRIPTION	QUANTITY
	FRONT YARD SHADE TREE(S)	1
	REAR YARD SHADE TREE(S)	1
	ORNAMENTAL TREE(S)	2
	EVERGREEN SCREENING	40%
	EVERGREEN GROUND COVER	10%
	PERENNIALS	25%
	ORNAMENTAL GRASSES	10%
	ORNAMENTAL SHRUBS	15%
	PLANTER BED COVERAGE	30%

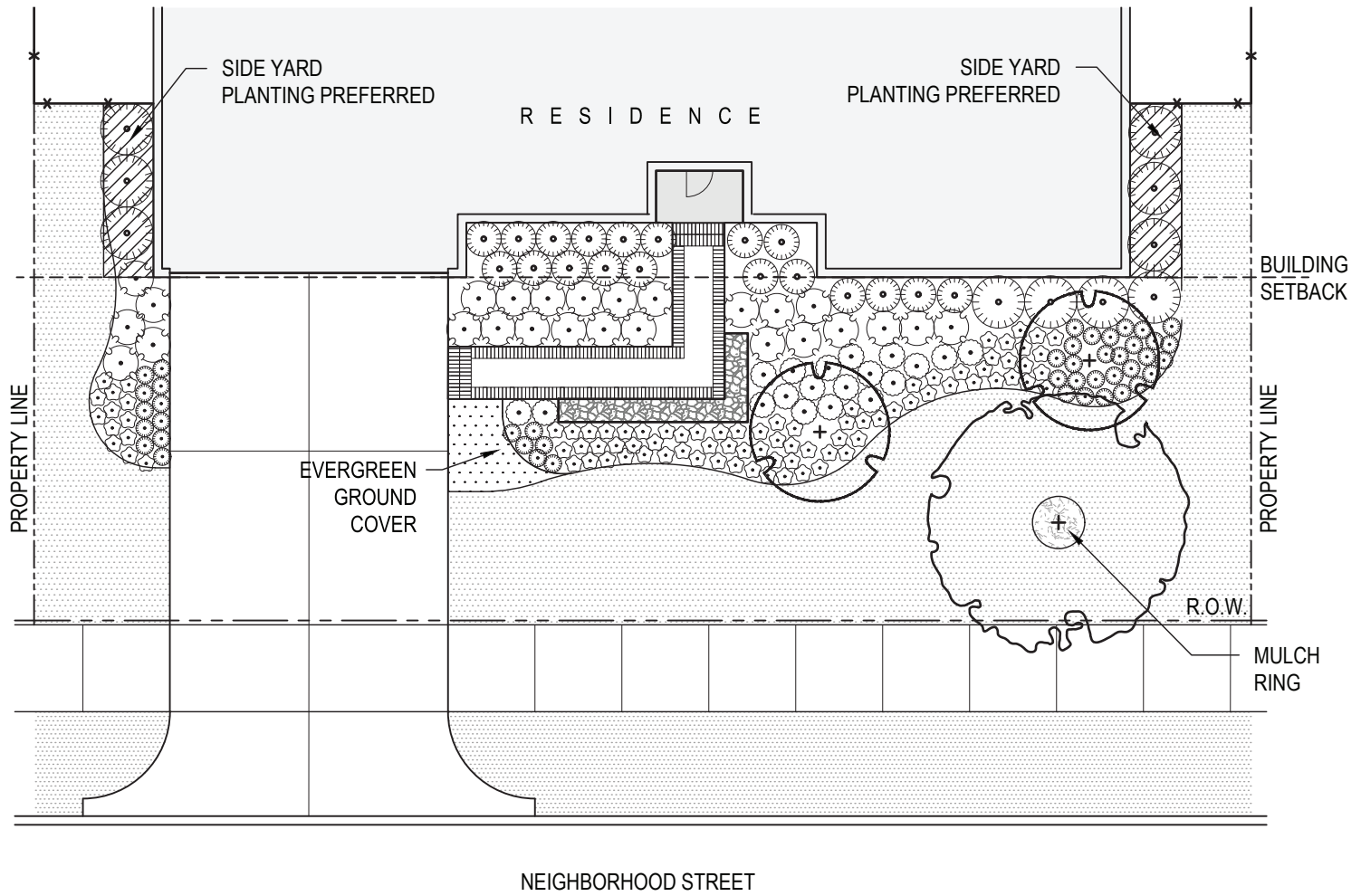

NOTES

1. REFERENCE LANDSCAPE REQUIREMENTS, APPROVED PLANTING LIST & FRONT ENTRY WALK STANDARD NOTES.
2. FRONT YARD SHALL REQUIRE FULL IRRIGATION.
3. SOD SHALL BE CELEBRATION BERMUDA.
4. PLANTER BED COVERAGE TO REQUIRE 2"-3" OF HARDWOOD MULCH.
5. NO VEGETATION SHALL BLOCK THE FLOW OF WATER OFF OF WALKS, IMPEDE LOT DRAINAGE, OR BLOCK ADDRESS MARKER.
6. TREE MULCH PER PLANTING SPECIFICATIONS.
7. PLANTING ON STREET SIDE OF ACCENT WALL NOT TO EXCEED 1'-0" IN HEIGHT.
8. PLANTER BED COVERAGE SHALL BE 30% OF THE FRONT YARD (INCLUDES SOFTSCAPE AREA FROM FACE OF RESIDENCE TO BACK OF CURB), REF EXHIBIT "B1": "TYPICAL ZONES - FRONT YARD, SIDE YARD & REAR YARD".
9. ALL LOTS TO RECEIVE REAR YARD SHADE TREES, REF. REAR YARD TREE REQUIREMENTS TABLE ON EXHIBITS "B10" & "B11".

70' & 80' LOT REQUIREMENTS		
SYMBOL	DESCRIPTION	QUANTITY
	FRONT YARD SHADE TREE(S)	1
	REAR YARD SHADE TREE(S)	2
	ORNAMENTAL TREE(S)	2
	EVERGREEN SCREENING	40%
	EVERGREEN GROUND COVER	10%
	PERENNIALS	25%
	ORNAMENTAL GRASSES	10%
	ORNAMENTAL SHRUBS	15%
	PLANTER BED COVERAGE	30%

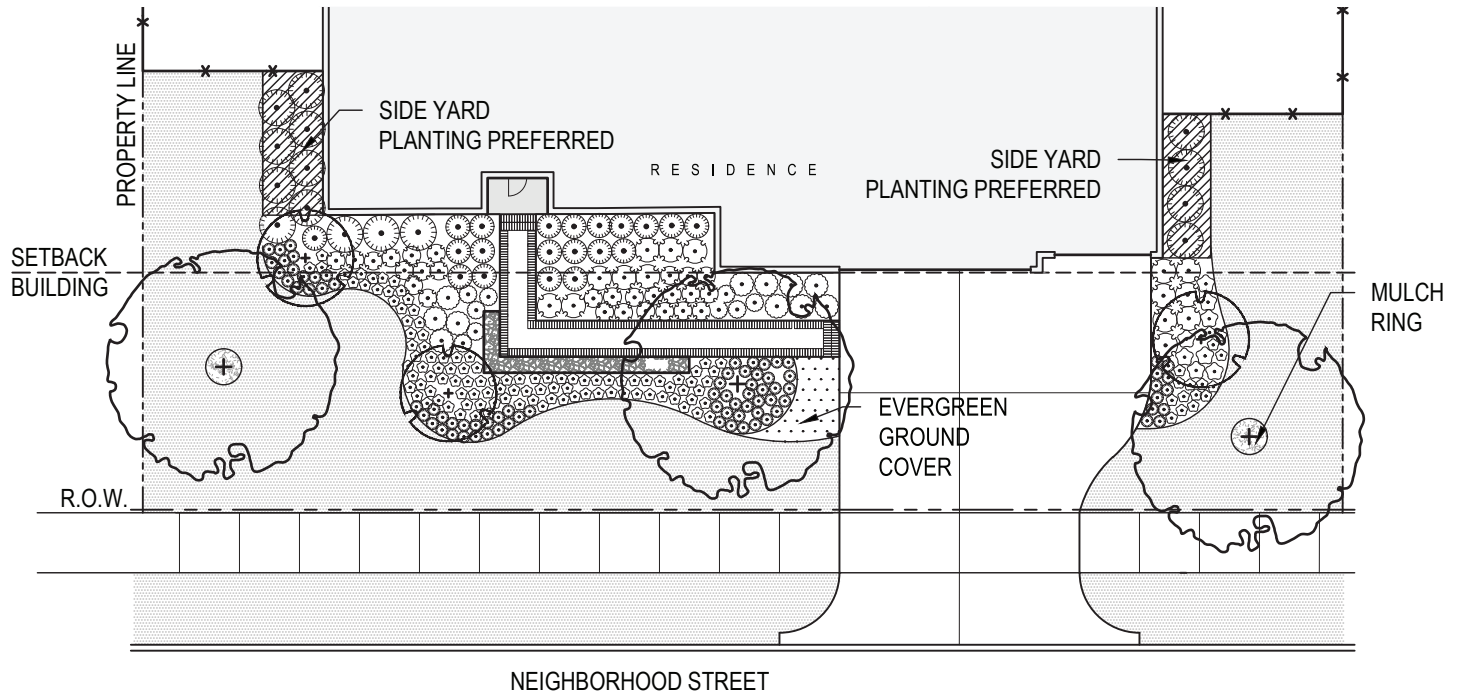

NOTES

1. REFERENCE LANDSCAPE REQUIREMENTS, APPROVED PLANTING LIST & FRONT ENTRY WALK STANDARD NOTES.
2. FRONT YARD SHALL REQUIRE FULL IRRIGATION.
3. SOD SHALL BE CELEBRATION BERMUDA.
4. PLANTER BED COVERAGE TO REQUIRE 2"-3" OF HARDWOOD MULCH.
5. NO VEGETATION SHALL BLOCK THE FLOW OF WATER OFF OF WALKS, IMPEDE LOT DRAINAGE, OR BLOCK ADDRESS MARKER.
6. TREE MULCH PER PLANTING SPECIFICATIONS.
7. PLANTING ON STREET SIDE OF ACCENT WALL NOT TO EXCEED 1'-0" IN HEIGHT.
8. PLANTER BED COVERAGE SHALL BE 30% OF THE FRONT YARD (INCLUDES SOFTSCAPE AREA FROM FACE OF RESIDENCE TO BACK OF CURB), REF EXHIBIT "B1": "TYPICAL ZONES - FRONT YARD, SIDE YARD & REAR YARD".
9. ALL LOTS TO RECEIVE REAR YARD SHADE TREES, REF. REAR YARD TREE REQUIREMENTS TABLE ON EXHIBITS "B10" & "B11".

100'+ LOT REQUIREMENTS		
SYMBOL	DESCRIPTION	QUANTITY
	FRONT YARD SHADE TREE(S)	3
	REAR YARD SHADE TREE(S)	2
	ORNAMENTAL TREE(S)	3
	EVERGREEN SCREENING	40%
	EVERGREEN GROUND COVER	10%
	PERENNIALS	25%
	ORNAMENTAL GRASSES	10%
	ORNAMENTAL SHRUBS	15%
	PLANTER BED COVERAGE	30%

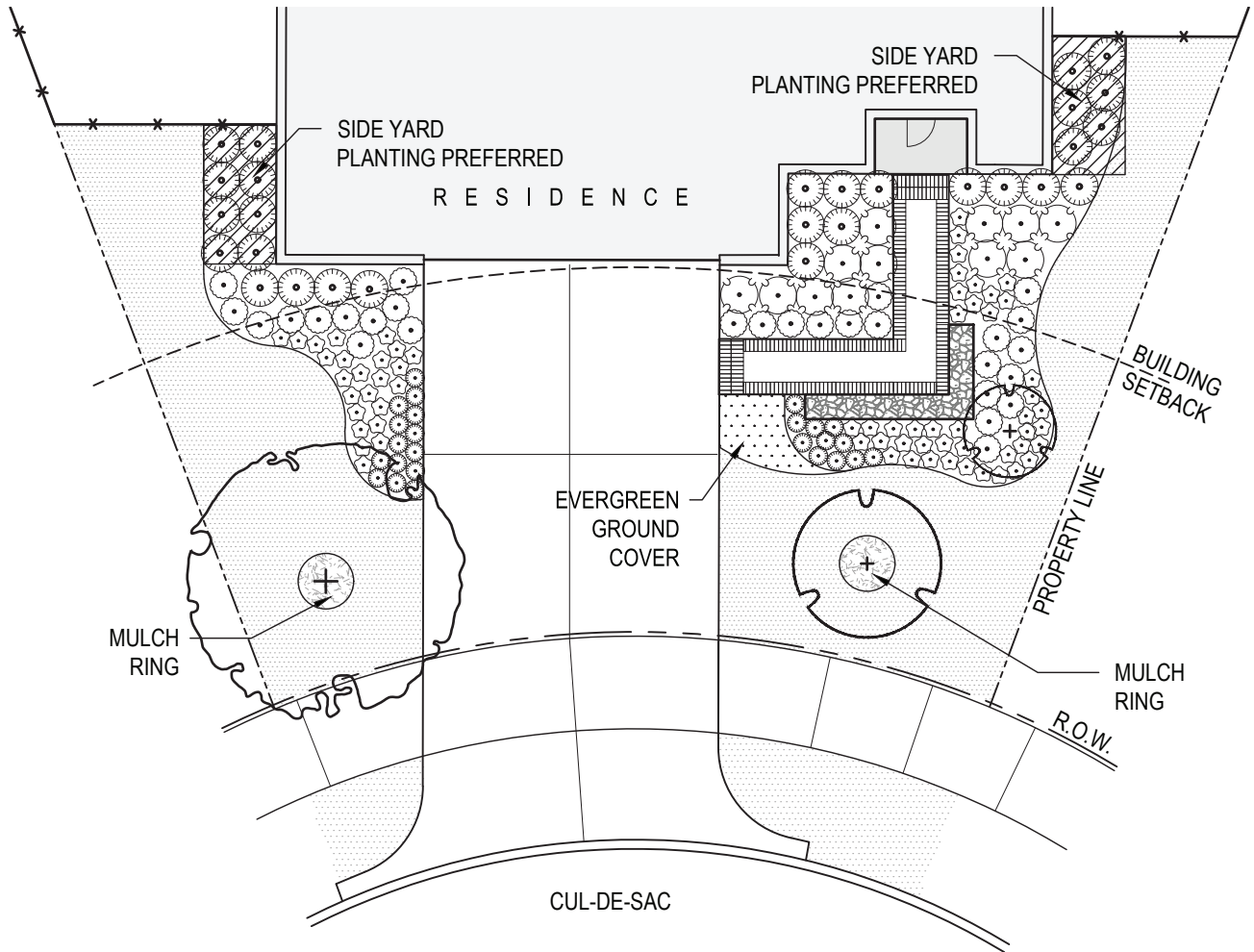

NOTES

1. REFERENCE LANDSCAPE REQUIREMENTS, APPROVED PLANTING LIST & FRONT ENTRY WALK STANDARD NOTES.
2. FRONT YARD SHALL REQUIRE FULL IRRIGATION.
3. SOD SHALL BE CELEBRATION BERMUDA.
4. PLANTER BED COVERAGE TO REQUIRE 2"-3" OF HARDWOOD MULCH.
5. NO VEGETATION SHALL BLOCK THE FLOW OF WATER OFF OF WALKS, IMPEDE LOT DRAINAGE, OR BLOCK ADDRESS MARKER.
6. TREE MULCH PER PLANTING SPECIFICATIONS.
7. PLANTING ON STREET SIDE OF ACCENT WALL NOT TO EXCEED 1'-0" IN HEIGHT.
8. PLANTER BED COVERAGE SHALL BE 30% OF THE FRONT YARD (INCLUDES SOFTSCAPE AREA FROM FACE OF RESIDENCE TO BACK OF CURB), REF EXHIBIT "B1": "TYPICAL ZONES - FRONT YARD, SIDE YARD & REAR YARD".
9. ALL LOTS TO RECEIVE REAR YARD SHADE TREES, REF. REAR YARD TREE REQUIREMENTS TABLE ON EXHIBITS "B10" & "B11".

CUL-DE-SAC LOT REQUIREMENTS		
SYMBOL	DESCRIPTION	QUANTITY
	FRONT YARD SHADE TREE(S)	1
	REAR YARD SHADE TREE(S)	(VARIES)
	ORNAMENTAL TREE(S)	1
	EVERGREEN SCREENING	40%
	EVERGREEN GROUNDCOVER	10%
	PERENNIALS	25%
	ORNAMENTAL GRASSES	10%
	ORNAMENTAL SHRUBS	15%
	PLANTER BED COVERAGE	30%

LANDSCAPE REQUIREMENTS - SIDE YARD (FRONT-LOADED CORNER LOT) - TYPICAL

SCALE: NTS

B7

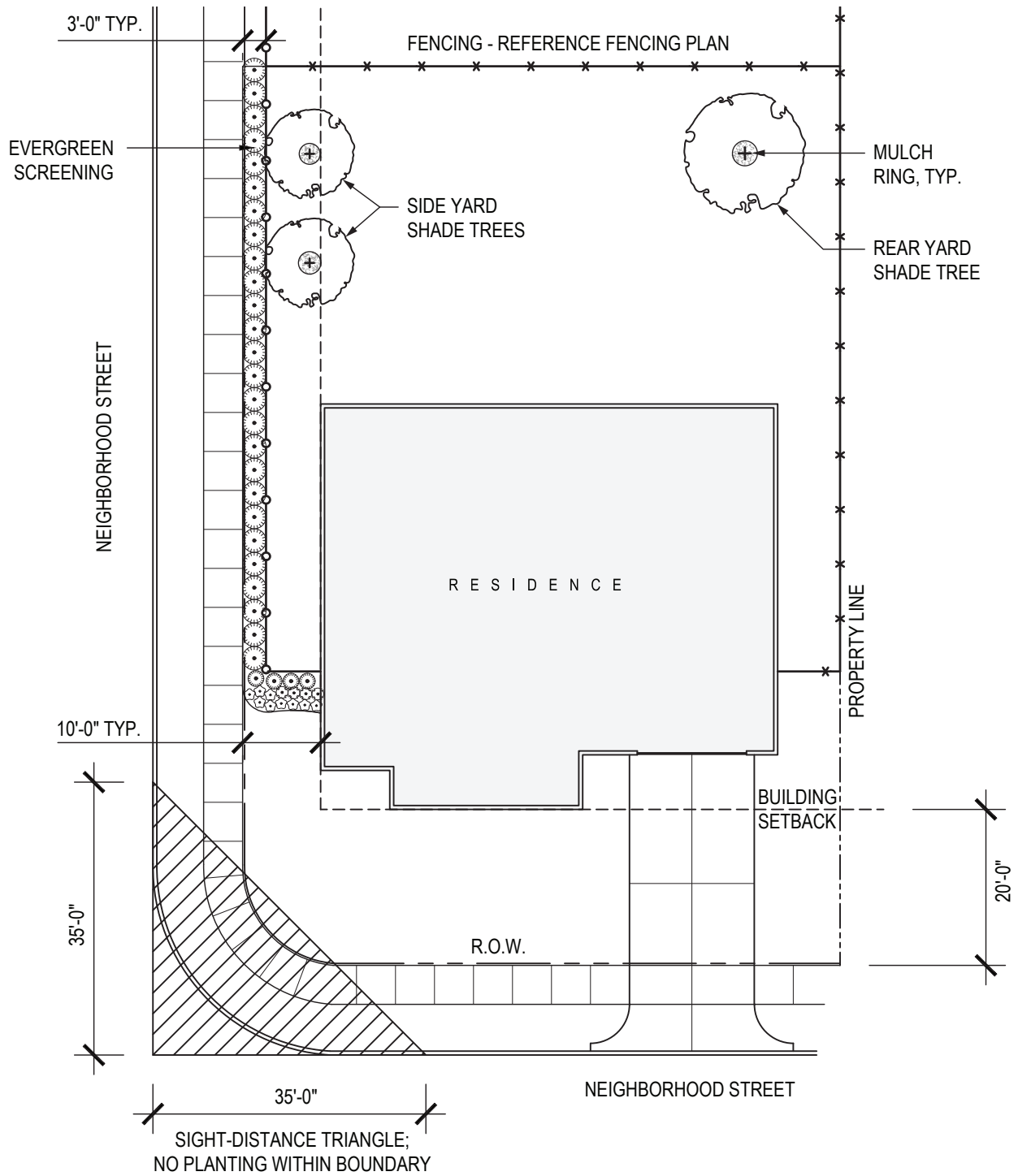

NOTES

1. APPROVED EVERGREEN SCREENING PLANTS TO BE INSTALLED IN A SINGLE ROW ALONG SLAB TO CREATE CONTINUOUS SCREEN.
2. REFERENCE LANDSCAPE REQUIREMENTS & APPROVED PLANTING LIST.
3. SOD SHALL BE CELEBRATION BERMUDA.
4. PLANTER BED COVERAGE TO REQUIRE 2"-3" OF HARDWOOD MULCH.
5. SHADE TREES IN REAR YARD TO BE 2 1/2" CALIPER.
6. PLANTING SHALL NOT IMPEDE LOT DRAINAGE.
7. SIDE YARD TO REQUIRE FULL IRRIGATION.
8. PLANTER BED COVERAGE TO CONSIST OF MIN. 50% EVERGREEN PLANTING, 25% PERENNIAL PLANTING, AND 25% ORNAMENTAL PLANTING.
9. TREE MULCH PER PLANTING SPECIFICATIONS.

CORNER LOT TREE REQUIREMENTS	
SHADE TREE LOCATION	QUANTITY
SIDE YARD	2
REAR YARD	1

10. ALL LOTS TO RECEIVE REAR YARD SHADE TREES, REF. REAR YARD TREE REQUIREMENTS TABLE ON EXHIBITS "B10" & "B11".

LANDSCAPE REQUIREMENTS - SIDE YARD (AT LAKE) - TYPICAL

SCALE: NTS

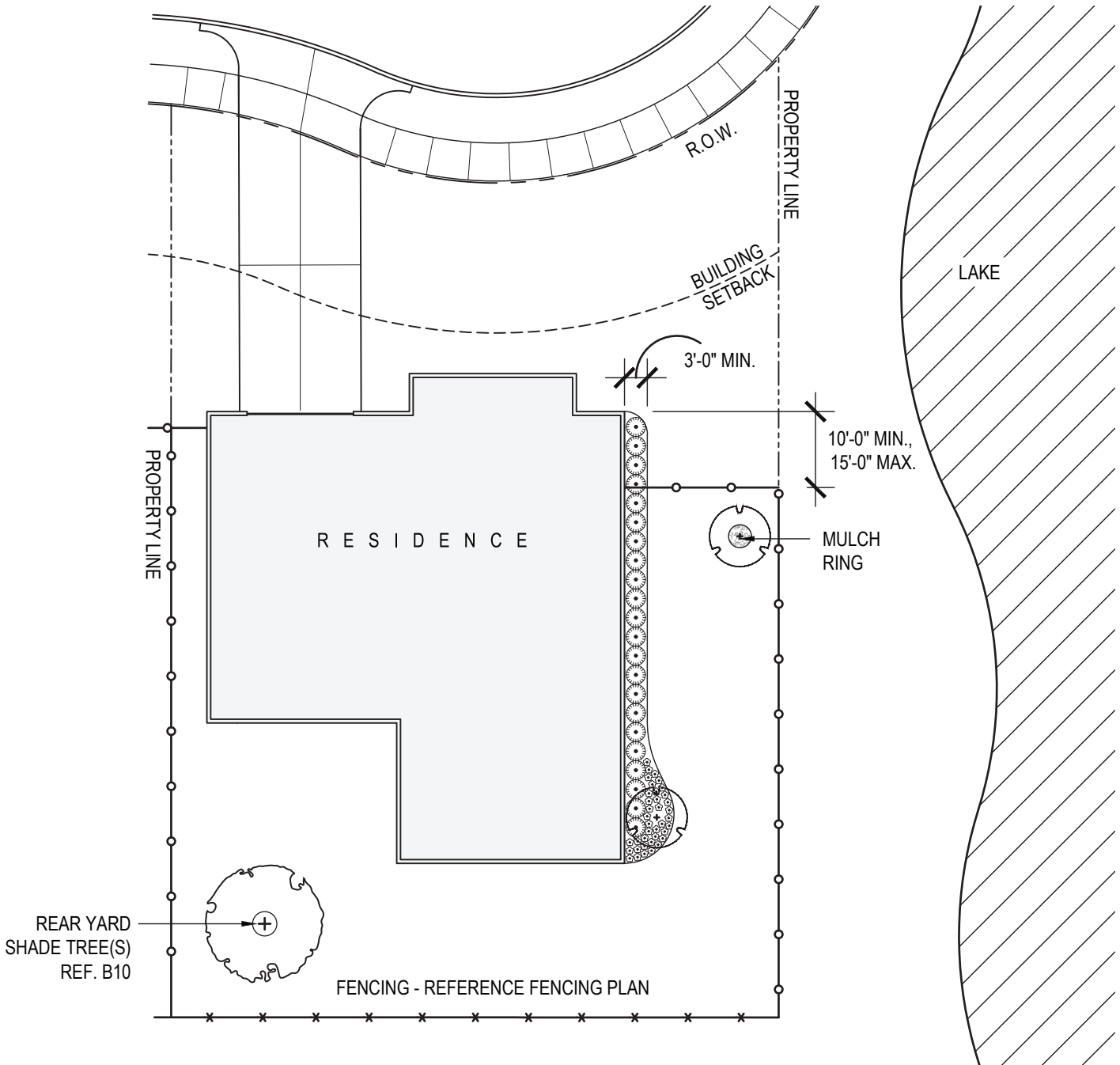

NOTES

1. APPROVED EVERGREEN SCREENING PLANTS TO BE INSTALLED IN A SINGLE ROW ALONG SLAB TO CREATE CONTINUOUS SCREEN.
2. REFERENCE LANDSCAPE REQUIREMENTS & APPROVED PLANTING LIST.
3. SOD SHALL BE CELEBRATION BERMUDA.
4. PLANTER BED COVERAGE TO REQUIRE 2"-3" OF HARDWOOD MULCH.
5. SHADE TREES IN REAR YARD TO BE 2 1/2" CALIPER.
6. REAR YARD AMENITY LOTS TO REQUIRE FULL IRRIGATION.
7. PLANTING SHALL NOT IMPEDE LOT DRAINAGE.
8. SIDE YARD TO REQUIRE FULL IRRIGATION.
9. PLANTER BED COVERAGE TO CONSIST OF MIN. 50% EVERGREEN PLANTING, 25% PERENNIAL PLANTING, AND 25% ORNAMENTAL PLANTING.
10. TREE MULCH PER PLANTING SPECIFICATIONS.

SIDE YARD TREE REQUIREMENTS		
LOT SIZE	SHADE TREES	ORNAMENTAL TREES
ALL	0	2
REAR YARD TREE REQUIREMENTS		
LOT SIZE	SHADE TREES	ORNAMENTAL TREES
50' OR LESS	1	0
55' - 65'	1	0
70' & 80'	2	0
100' OR GREATER	2	0
CUL-DE-SAC	(VARIES)	0

LANDSCAPE REQUIREMENTS - TYPICAL SIDE YARD (AT GREENBELT)

SCALE: NTS

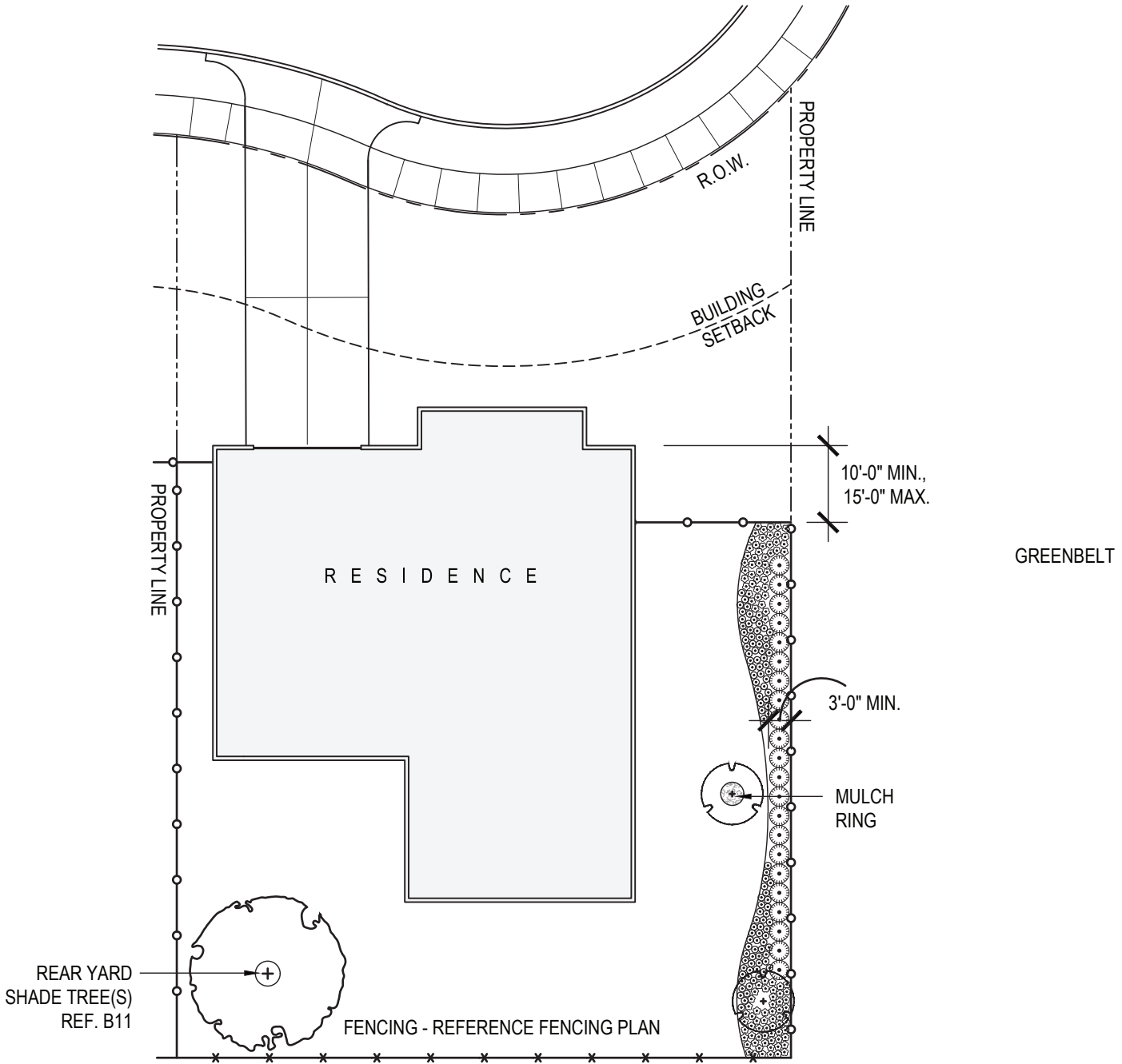

NOTES

1. APPROVED EVERGREEN SCREENING PLANTS TO BE INSTALLED IN A SINGLE ROW ALONG SLAB TO CREATE CONTINUOUS SCREEN.
2. REFERENCE LANDSCAPE REQUIREMENTS & APPROVED PLANTING LIST.
3. SOD SHALL BE CELEBRATION BERMUDEA.
4. PLANTER BED COVERAGE TO REQUIRE 2"-3" OF HARDWOOD MULCH.
5. SHADE TREES IN REAR YARD TO BE 2 1/2" CALIPER.
6. REAR YARD AMENITY LOTS TO REQUIRE FULL IRRIGATION.
7. PLANTING SHALL NOT IMPEDE LOT DRAINAGE.
8. SIDE YARD TO REQUIRE FULL IRRIGATION.
9. PLANTER BED COVERAGE TO CONSIST OF MIN. 50% EVERGREEN PLANTING, 25% PERENNIAL PLANTING, AND 25% ORNAMENTAL PLANTING.
10. TREE MULCH PER PLANTING SPECIFICATIONS.

SIDE YARD TREE REQUIREMENTS		
LOT SIZE	SHADE TREES	ORNAMENTAL TREES
ALL	0	2
REAR YARD TREE REQUIREMENTS		
LOT SIZE	SHADE TREES	ORNAMENTAL TREES
50' OR LESS	1	0
55' - 65'	1	0
70' & 80'	2	0
100' OR GREATER	2	0
CUL-DE-SAC	(VARIES)	0

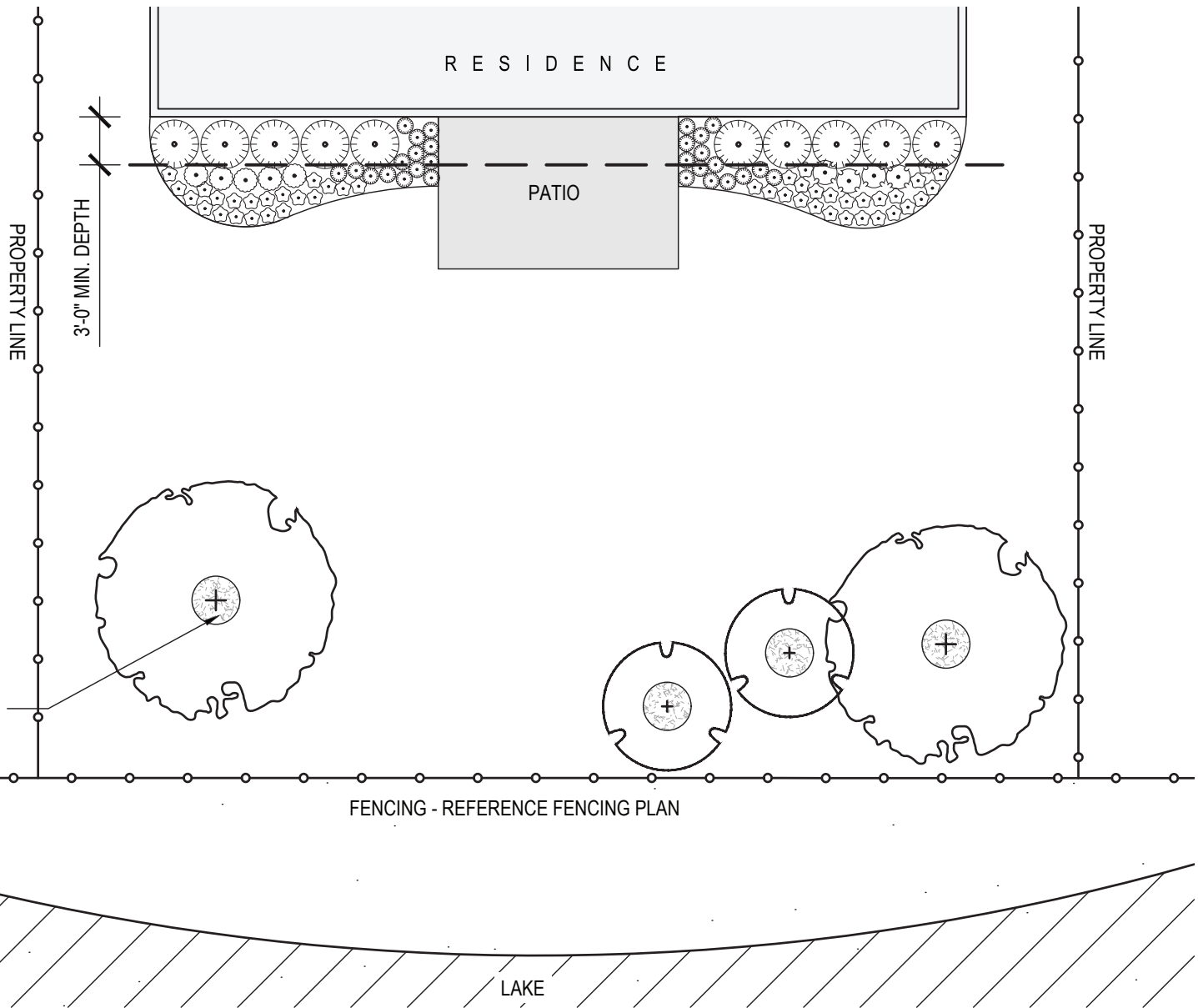

NOTES

1. REFERENCE LANDSCAPE REQUIREMENTS & APPROVED PLANTING LIST.
2. SOD SHALL BE CELEBRATION BERMUDA.
3. PLANTER BED COVERAGE TO REQUIRE 2"-3" OF HARDWOOD MULCH.
4. SHADE TREES IN REAR YARD TO BE 2 1/2" CALIPER.
5. REAR YARD AMENITY LOTS TO REQUIRE FULL IRRIGATION.
6. PLANTING SHALL NOT IMPEDE LOT DRAINAGE
7. PLANTER BED COVERAGE TO CONSIST OF MIN. 50% EVERGREEN PLANTING, 25% PERENNIAL PLANTING, AND 25% ORNAMENTAL PLANTING.
8. TREE MULCH PER PLANTING SPECIFICATIONS.
9. ALL LOTS TO RECEIVE REAR YARD SHADE TREES, REF. REAR YARD TREE REQUIREMENTS TABLE ON THIS EXHIBIT "B10" & "B11".

REAR YARD TREE REQUIREMENTS		
LOT SIZE	SHADE TREES	ORNAMENTAL TREES
50' OR LESS	1	1
55' - 65'	1	1
70' & 80'	2	2
100' OR GREATER	2	2
CUL-DE-SAC	(VARIES)	(VARIES)

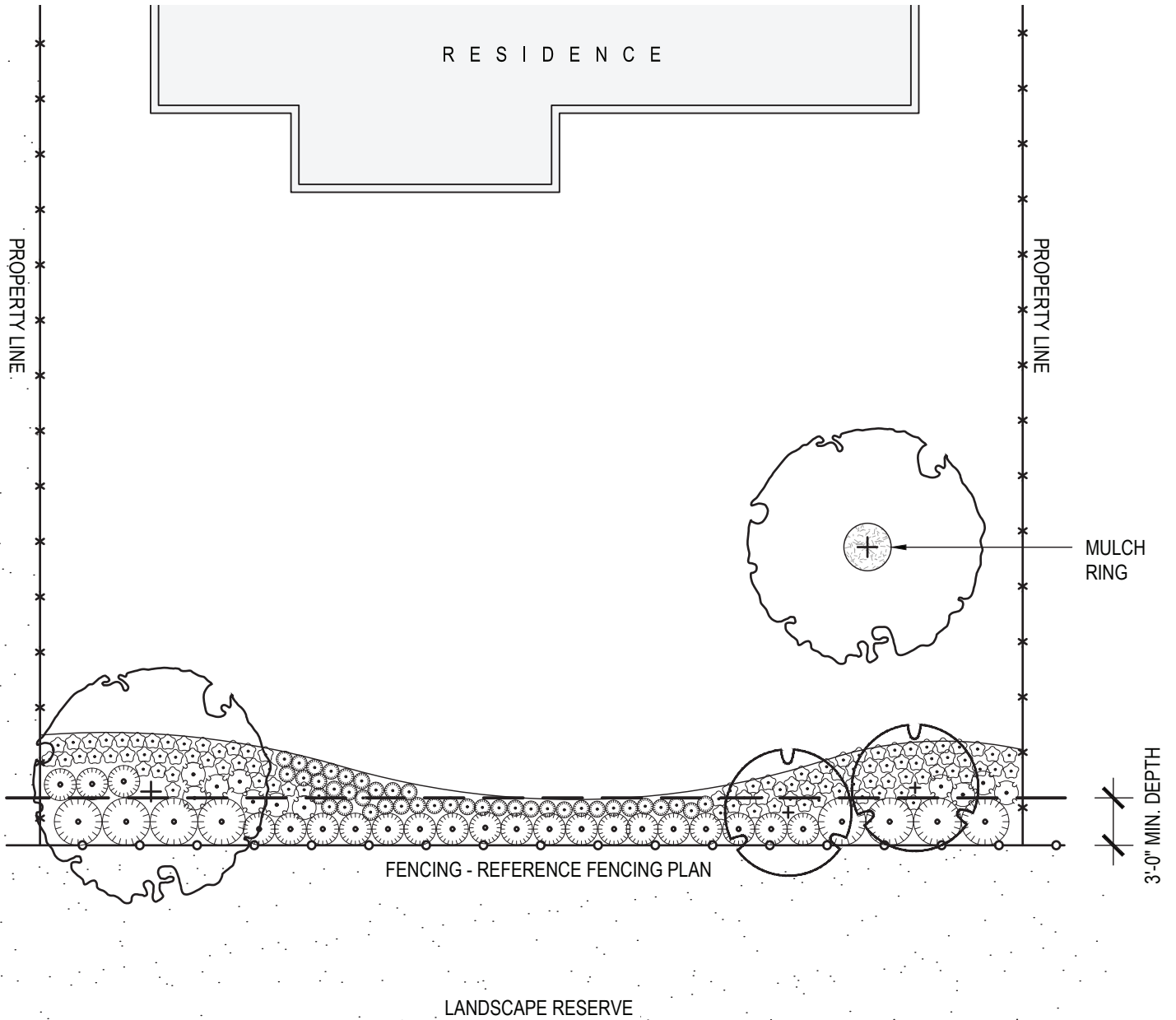

NOTES

1. APPROVED EVERGREEN SCREENING PLANTS TO BE INSTALLED IN A SINGLE ROW ALONG FENCE TO CREATE CONTINUOUS SCREEN.
2. REFERENCE LANDSCAPE REQUIREMENTS & APPROVED PLANTING LIST.
3. SOD SHALL BE CELEBRATION BERMUDA.
4. PLANTER BED COVERAGE TO REQUIRE 2"-3" OF HARDWOOD MULCH.
5. SHADE TREES IN REAR YARD TO BE 2 1/2" CALIPER.
6. REAR YARD AMENITY LOTS TO REQUIRE FULL IRRIGATION.
7. PLANTING SHALL NOT IMPEDE LOT DRAINAGE
8. PLANTER BED COVERAGE TO CONSIST OF MIN. 50% EVERGREEN PLANTING, 25% PERENNIAL PLANTING, AND 25% ORNAMENTAL PLANTING.
9. TREE MULCH PER PLANTING SPECIFICATIONS.
10. ALL LOTS TO RECEIVE REAR YARD SHADE TREES, REF. REAR YARD TREE REQUIREMENTS TABLE ON EXHIBITS "B10" & "B11".

REAR YARD TREE REQUIREMENTS		
LOT SIZE	SHADE TREES	ORNAMENTAL TREES
50' OR LESS	1	1
55' - 65'	1	1
70' & 80'	2	2
100' OR GREATER	2	2
CUL-DE-SAC	(VARIES)	(VARIES)

SHADE TREES

2.5" - 3" Caliper, measured 2' above natural grade

Botanical Name	Common Name
<i>Magnolia grandiflora</i>	Southern Magnolia
<i>Pinus taeda</i>	Loblolly Pine
<i>Platanus mexicana</i>	Mexican Sycamore
<i>Quercus alba</i>	White Oak
<i>Quercus nuttalli</i>	Nuttall Oak
<i>Quercus polymorpha</i>	Mexican White Oak
<i>Quercus shumardii</i>	Shumard Oak
<i>Quercus virginiana</i>	Live Oak
<i>Taxodium distichum</i>	Bald Cypress
<i>Ulmus americana</i> 'Princeton'	Princeton Elm
<i>Ulmus crassifolia</i>	Cedar Elm

ORNAMENTAL GRASSES

Recommended species

Botanical Name	Common Name
<i>Bouteloua gracilis</i>	Blue Grama
<i>Miscanthus gracillimus</i>	Maiden Grass
<i>Miscanthus sinensis</i> 'Adagio'	Adagio Fountain Grass
<i>Miscanthus sinensis</i> 'Little Kitten'	Little Kitten Grass
<i>Muhlenbergia capillaris</i>	Gulf Coast Muhly
<i>Muhlenbergia capillaris</i> 'White Cloud'	White Cloud Muhly
<i>Muhlenbergia lindheimeri</i>	Lindheimer Muhly
<i>Muhlenbergia dumosa</i>	Bamboo Muhly
<i>Pennisetum alopecuroides</i> 'Hameln'	Dwarf Pennisetum
<i>Schizachyrium scoparium</i>	Little Bluestem

ORNAMENTAL TREES

30 Gallon Minimum - (Tree Form Only)

Botanical Name	Common Name
<i>Cercis canadensis</i>	Redbud
<i>Chionanthus virginicus</i>	Fringetree
<i>Dermatophyllum secundiflora</i>	Texas Mountain Laurel
<i>Lagerstroemia indica</i>	Crape Myrtle Species
<i>Magnolia soulangeana</i>	Saucer Magnolia
<i>Magnolia stellata</i>	Star Magnolia
<i>Vitex agnus castus</i>	Chaste Tree

GROUNDCOVER

Recommended species

Botanical Name	Common Name
<i>Ficus tikoua</i>	Sandi Leaf Fig Ivy
<i>Phyla nodiflora</i>	Frogfruit
<i>Rosmarinus officinalis</i> 'Prostratus'	Creeping Rosemary
<i>Ruellia</i> 'Blue Shade'	Blue Shade Ruellia
<i>Scutellaria suffrutescens</i>	Texas Skullcap
<i>Wedelia</i> ssp.	Wedelia

EVERGREEN SCREENING / ACCENT

2' height minimum when installed

Botanical Name	Common Name
<i>Callistemon citrinus</i>	Bottlebrush
<i>Cuphea</i> 'David Verity'	David's Verity Cuphea
<i>Feijoa sellowiana</i>	Pineapple Guava
<i>Hamelia patens</i>	Dwarf Firebush
<i>Ilex</i> 'Cherry Bomb'	Cherry Bomb Holly
<i>Ilex opaca</i>	American Holly
<i>Ilex vomitoria</i>	Yaupon
<i>Itea virginica</i>	Virginia Sweetspire
<i>Justicia brandegeana</i>	Shrimp Plant
<i>Leucophyllum candidum</i>	Compact Texas Sage
<i>Leucophyllum frutescens</i>	Texas Sage
<i>Myrica cerifera</i>	Southern Wax Myrtle
<i>Nerium oleander</i>	Oleander
<i>Osmanthus fragrans</i>	Sweet Olive
<i>Rhododendron</i> ssp.	Azaela Species
<i>Viburnum dentatum</i>	Arrowwood Viburnum
<i>Viburnum obovatum</i>	Walters Viburnum
<i>Viburnum obovatum</i> 'densa'	Compact Walter's Viburnum

ORNAMENTAL SHRUBS

5 gal. minimum

Botanical Name	Common Name
<i>Callicarpa americana</i>	Compact Beautyberry
<i>Ilex decidua</i>	Possumhaw
<i>Itea virginica</i> 'Little Henry'	Dwarf Virginia Sweetspire
<i>Lantana urticoides</i>	Texas Lantana
<i>Malvaviscus arboreus</i>	Turk's Cap
<i>Russelia equisetiformis</i>	Firecracker Plant
<i>Symphoricarpos orbiculatus</i>	Coralberry
<i>Tecoma stans</i>	Esperanza

(Plant List Continued on Next Page)

PERENNIAL

*Recommended species | * Native pollinator plant*

Botanical Name	Common Name
<i>Anthericum saundersiae</i>	Shooting Star Lily
<i>Asclepias tuberosa</i>	Native Texas Milkweed
<i>Conoclinium greggii</i>	Gregg's Mistflower
<i>Coreopsis grandiflora</i> 'Walcoreop'	Coreopsis
<i>Echinacea purpurea</i>	Purple Coneflower
<i>Englemania peristenia</i>	Cutleaf Daisy
<i>Eupatorium havanense</i>	White Mistflower
<i>Gaura lindheimeri</i> 'Whirling Butterflies'	Gaura
<i>Iris ssp.</i>	Iris Species
<i>Lantana montevidensis</i>	Trailing Lantana
<i>Penstemon tenuis</i>	Gulf Coast Penstemon
<i>Plumbago auriculata</i>	Plumbago
<i>Poliomintha longiflora</i>	Mexican Oregano
<i>Rudbeckia hirta</i>	Black Eyed Susan
<i>Salvia amistad</i>	Salvia Amistad
<i>Salvia coccinea</i>	Scarlet Sage
<i>Salvia greggi</i>	Autumn Sage
<i>Salvia greggi</i> 'Cherry Chief'	Cherry Chief Sage
<i>Salvia leucantha</i>	Mexican Bush Sage
<i>Salvia sylvestris</i> 'May Night'	May Night Salvia
<i>Scutellaria suffrutescens</i>	Red Skullcap
<i>Spiraea ssp.</i>	Spiraea Species

2 CAR GARAGE & DRIVEWAY - TYPICAL

SCALE: NTS

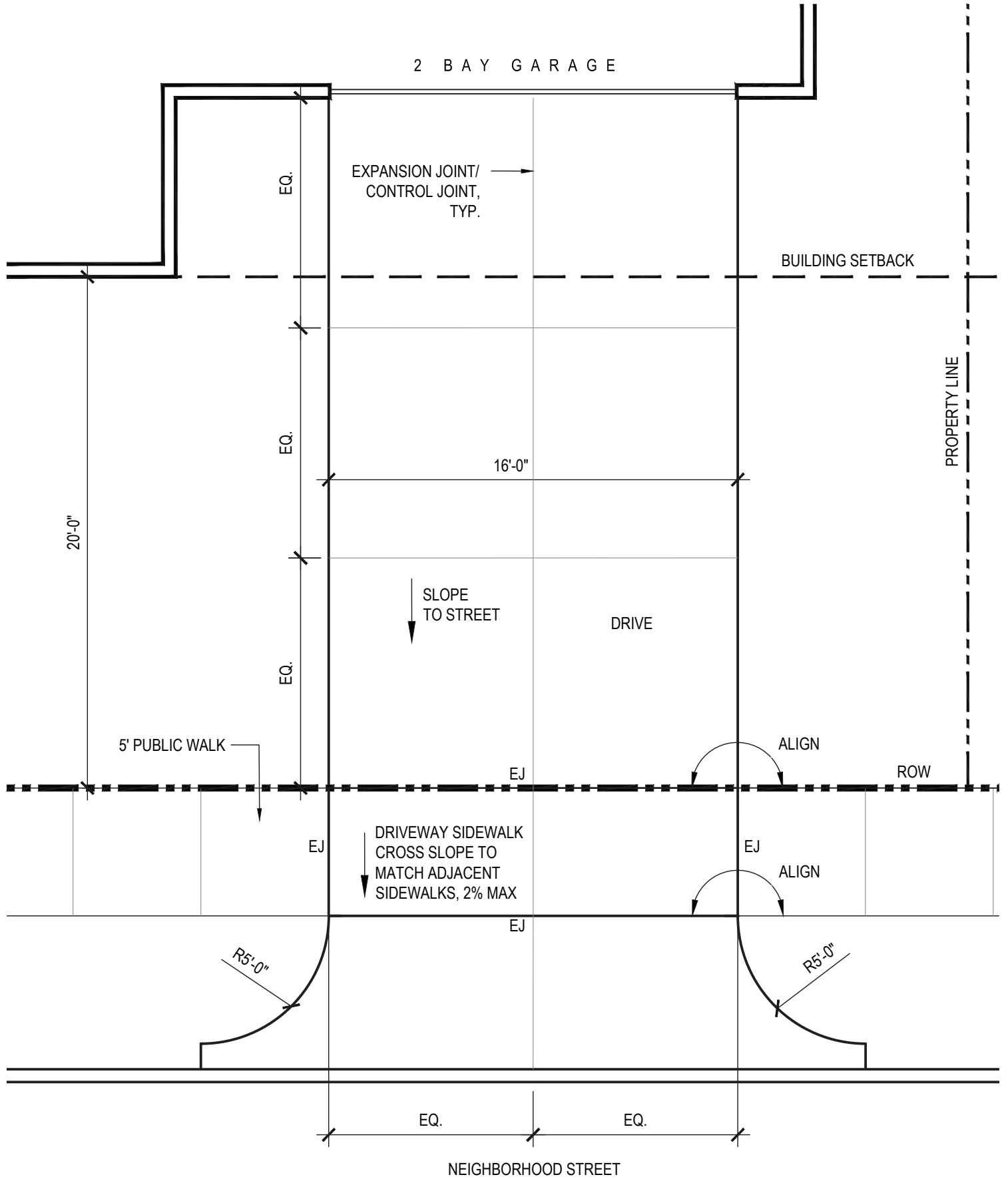

3 CAR GARAGE & DRIVEWAY - OPTION "A"

SCALE: NTS

C2-A

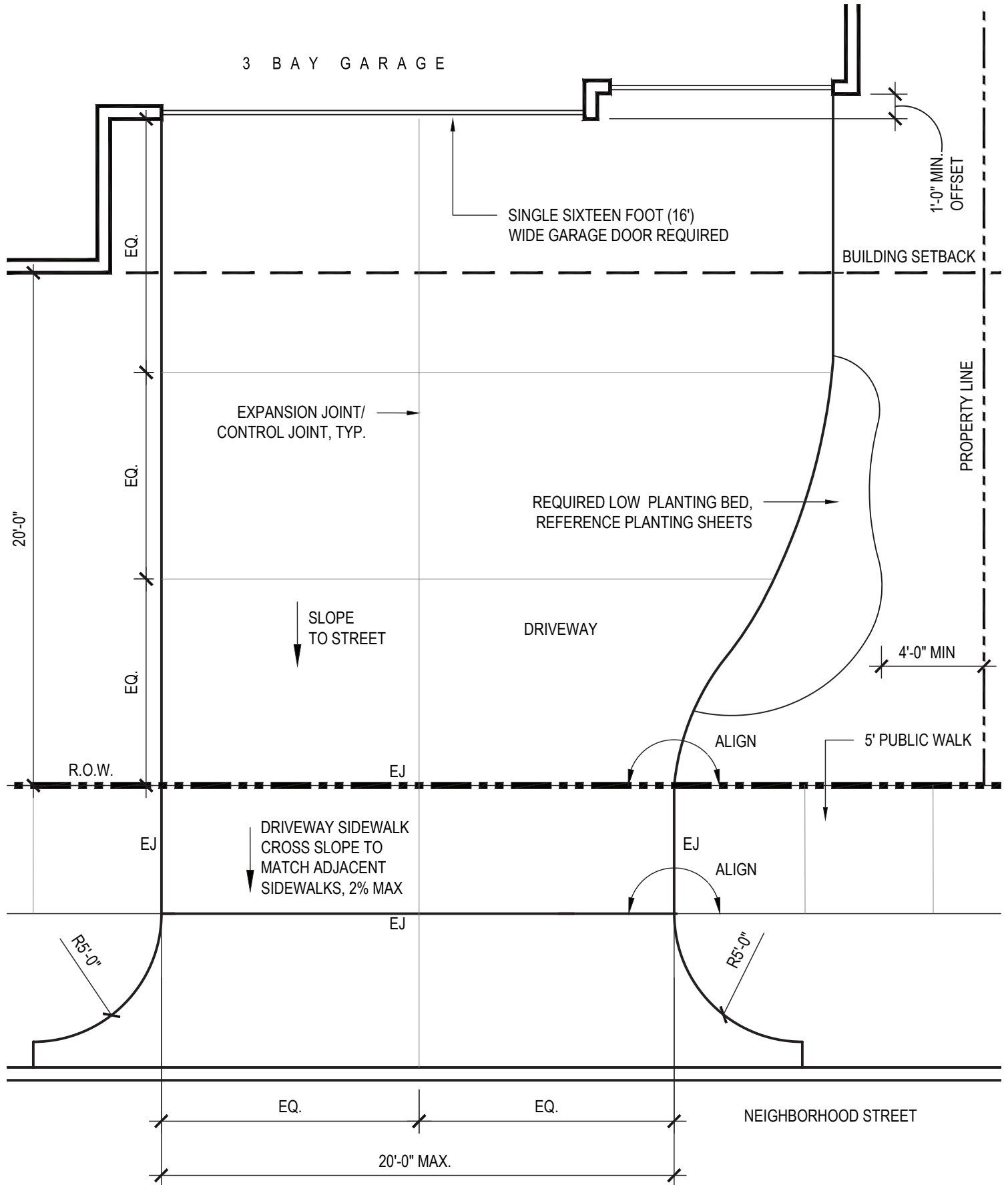

3 CAR GARAGE & DRIVEWAY - OPTION "B"

SCALE: NTS

C2-B

3 BAY GARAGE

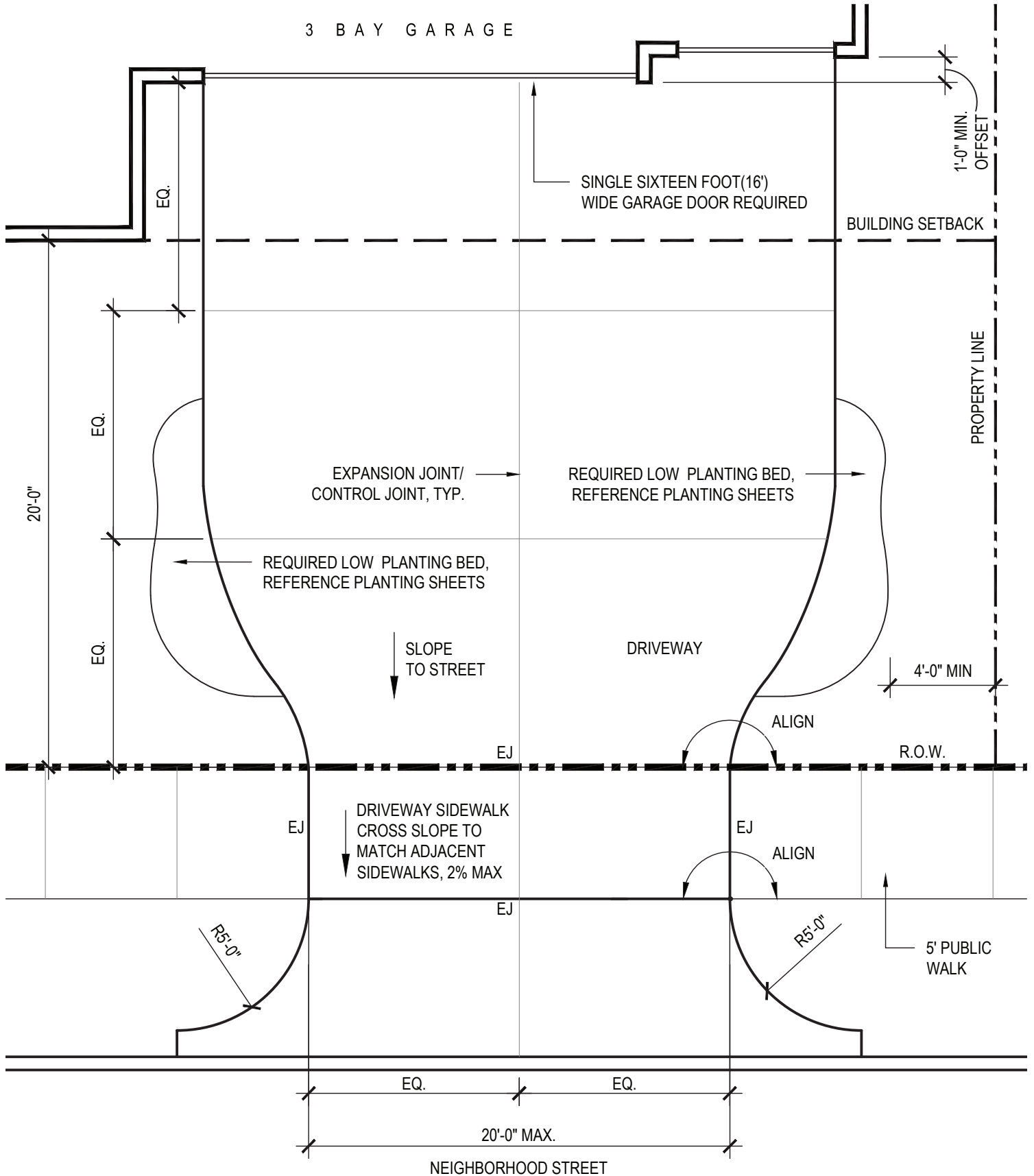

FENCE - DOUBLE-SIDED WOOD - TYPICAL

SCALE: NTS

DOUBLE-SIDED WOOD FENCE - TYPICAL

SCALE: NTS

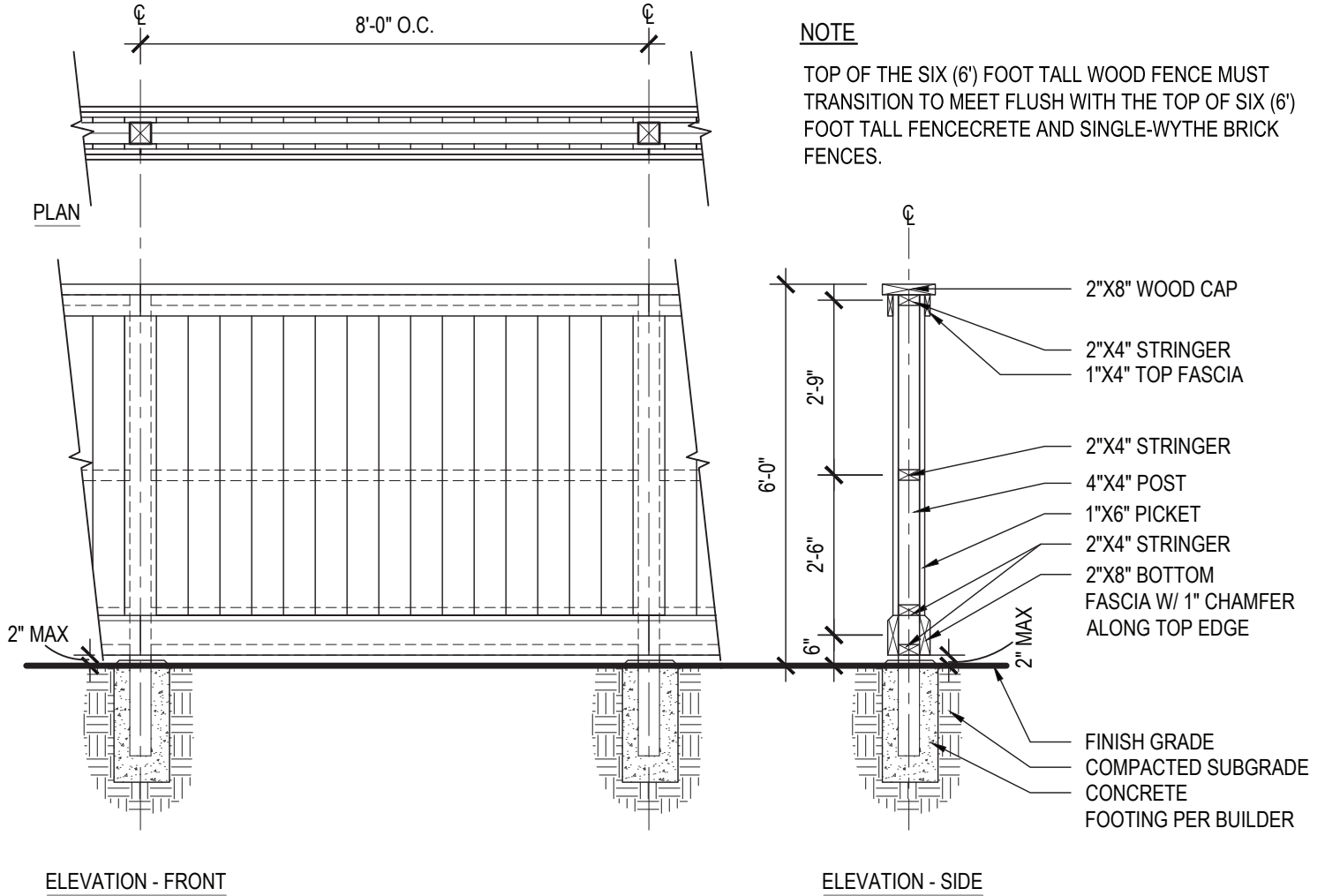

FENCING TRANSITION - DOUBLE-SIDED WOOD TO TUBE STEEL

SCALE: NTS

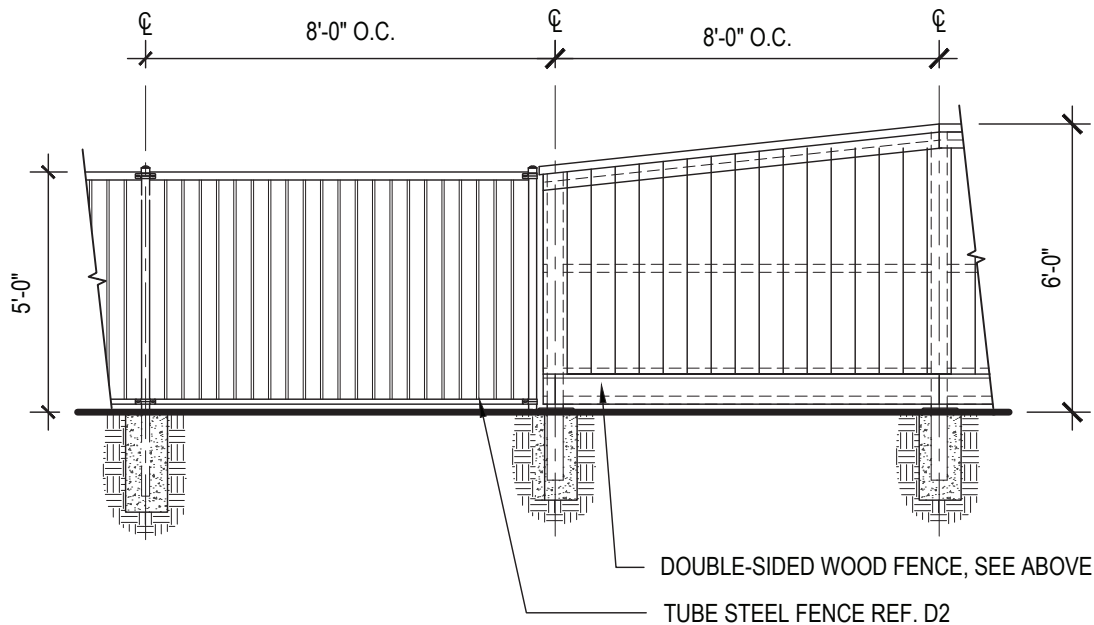

FENCE - DOUBLE-SIDED WOOD (ON SLOPE) - TYPICAL

SCALE: NTS

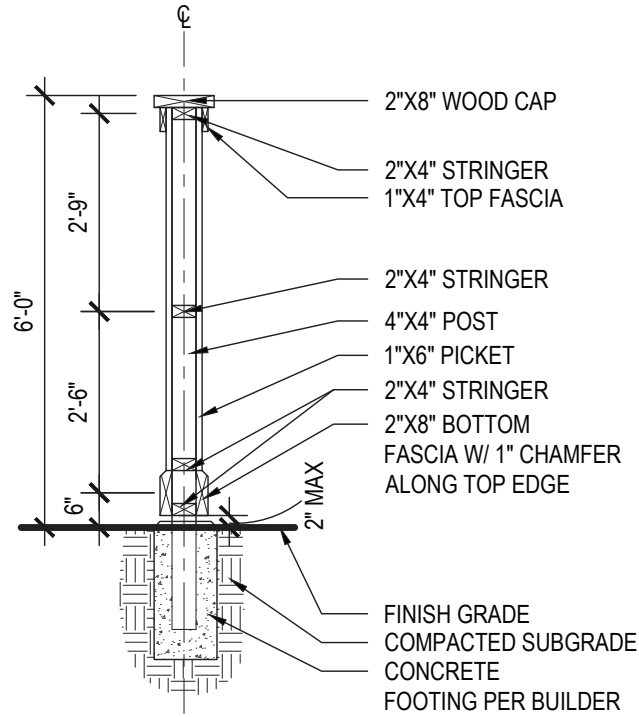

NOTE

TOP OF THE SIX (6') FOOT TALL WOOD FENCE MUST TRANSITION TO MEET FLUSH WITH THE TOP OF SIX (6') FOOT TALL FENCECRETE AND SINGLE-WYTHE BRICK FENCES.

SECTION

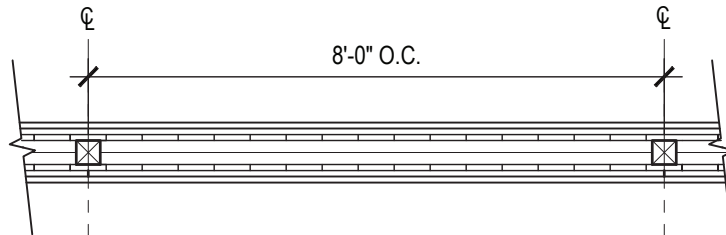

PLAN

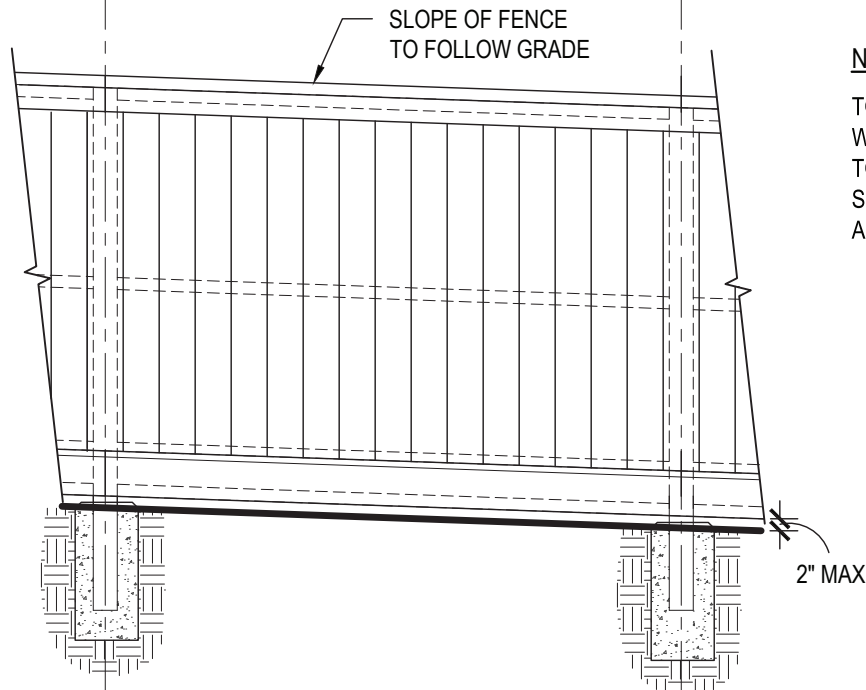

NOTE

TOP OF THE SIX (6') FOOT TALL WOOD FENCE MUST TRANSITION TO MEET FLUSH WITH THE TOP OF SIX (6') FOOT TALL FENCECRETE AND SINGLE-WYTHE BRICK FENCES.

ELEVATION

FENCE - TUBE STEEL - TYPICAL

SCALE: NTS

D3

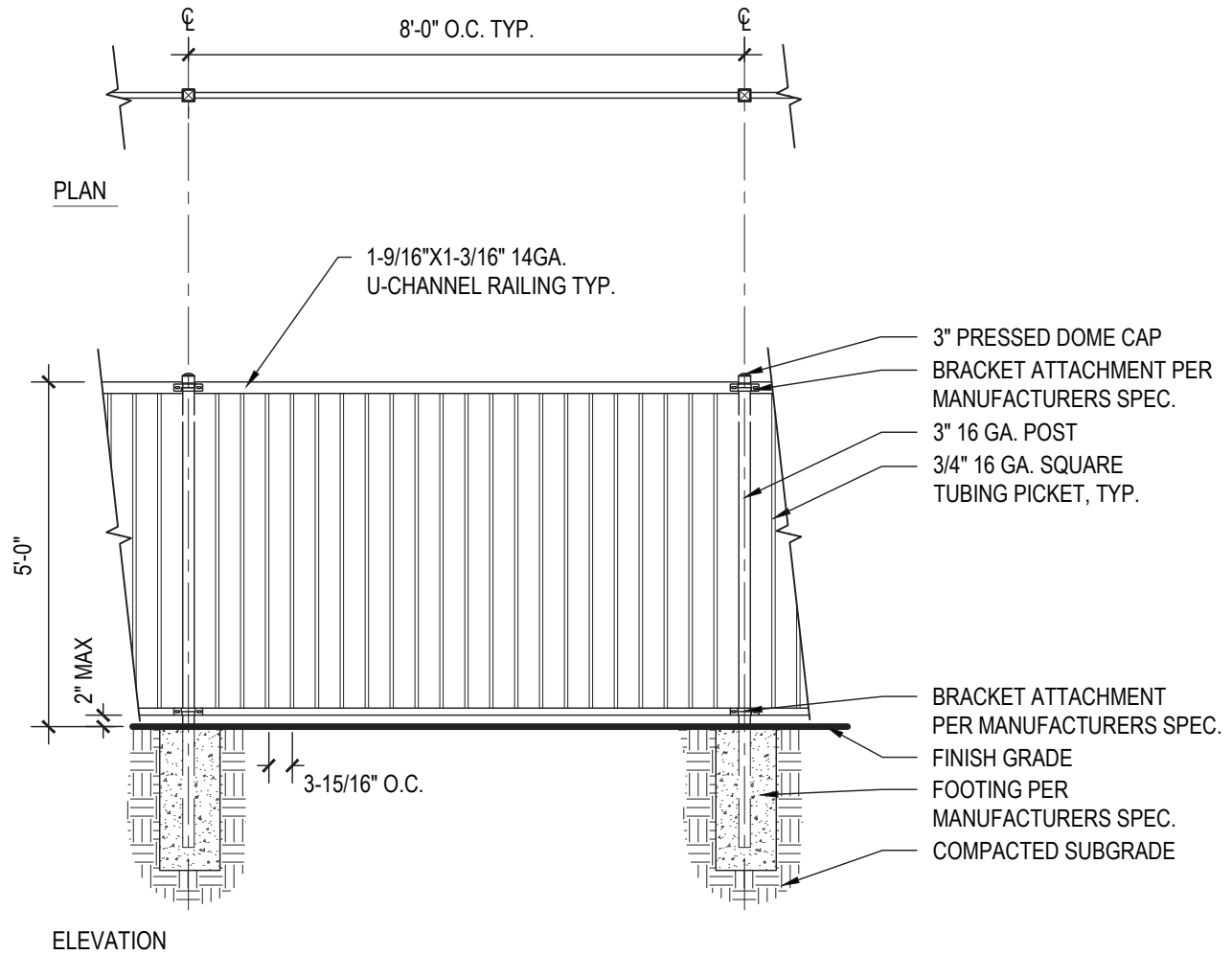

NOTES

1. TUBE STEEL FENCE SHALL BE V2 FT/FB2 COMMERCIAL FENCE (FLAT TOP, FLAT BOTTOM) AS PROVIDED BY FORTRESS FENCE PRODUCTS OR APPROVED EQUAL.
2. FENCE SHALL BE POOL BARRIER COMPLIANT.
3. REFERENCE MANUFACTURER'S RECOMMENDATIONS FOR INSTALLATION REGARDING WIND LOAD CAPACITY, FOOTING DEPTH, AND BRACKET ATTACHMENTS.
4. AS PER MANUFACTURER'S SPECIFICATIONS, FENCE PANELS MAY NOT BE INSTALLED ON A SLOPE GREATER THAN 21°.

FENCE - 6' SINGLE WYTHE BRICK (DEVELOPER INSTALLED)

SCALE: NTS

D4-A

ELEVATION - SIDE

SCALE: NTS

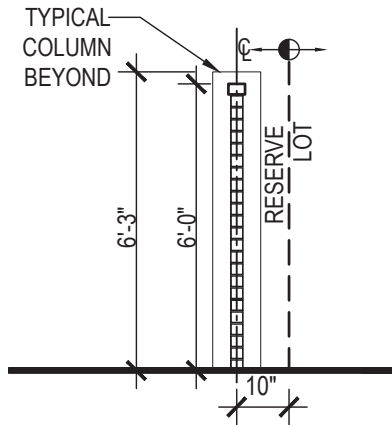

PLAN - TYPICAL COLUMN

SCALE: NTS

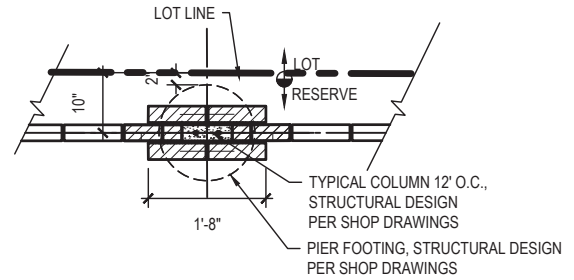

ELEVATION - FRONT

SCALE: NTS

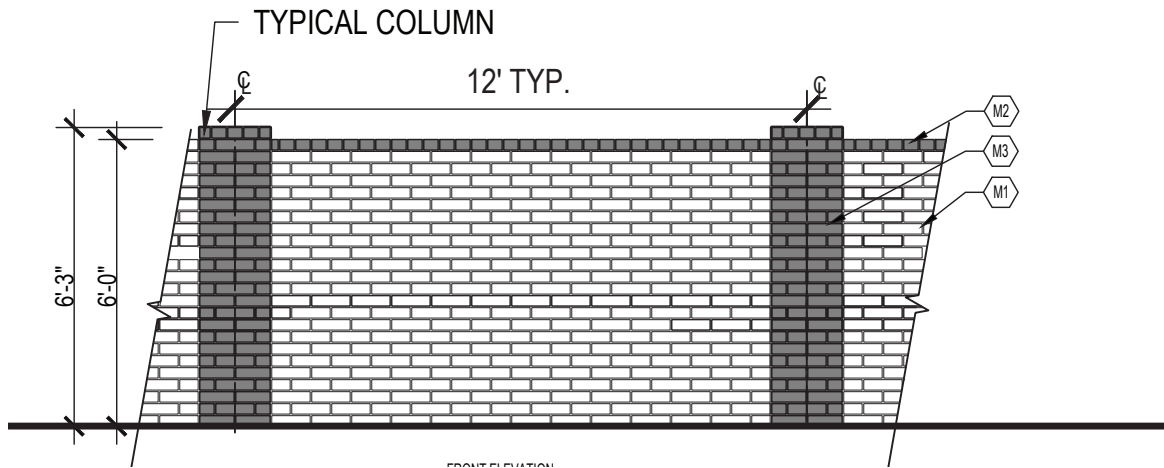

PLAN

SCALE: NTS

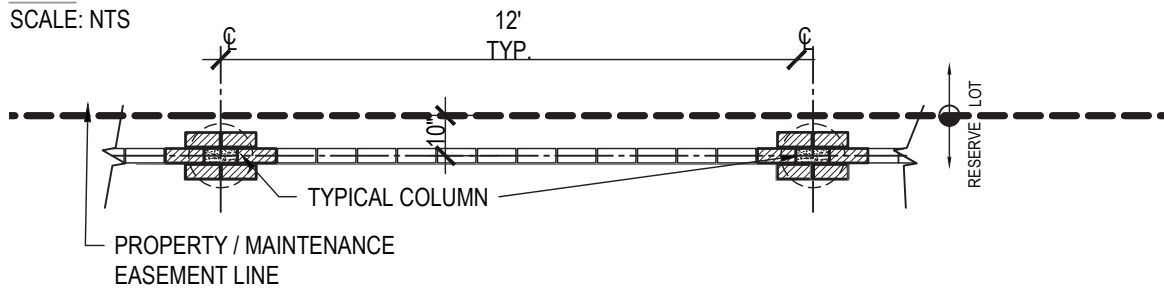

NOTES

1. ALL BRICK TO BE UTILITY KING SIZE BRICK FROM ACME WITH WIRECUT FINISH SEE MATERIAL KEY FOR FINISHES.
2. CONTRACTOR TO PROVIDE SIGNED AND SEALED STRUCTURAL DRAWINGS.
3. CONTRACTOR SHALL BE RESPONSIBLE FOR GRADING AT THE BOTTOM OF FENCE PANELS AND ADJACENT IMMEDIATE AREA. NO GAPS ALLOWED. TRANSITIONS TO ADJACENT GRADE SHALL BE GENTLE.
4. CENTER OF FENCE LINE SHOULD BE 6" OFFSET OUTSIDE FROM LOT LINE.
5. CORE HOLES SHALL NOT BE VISIBLE ON ANY EXPOSED SURFACE, INCLUDING TOP HEADER COURSE AND TOP OF COLUMN, NO GROUT CAPS ALLOWED.

MATERIAL KEY			
KEY	MATERIAL	PATTERN	COLOR
(M1)	ACME KING SIZE BRICKS; BRICK TYPE 1, WIRECUT FINISH	RUNNING BOND	MARBLE GRAY
(M2)	ACME KING SIZE BRICKS; BRICK TYPE 2, WIRECUT FINISH, SOLID BRICK	HEADER COURSE	SLATE GRAY
(M3)	ACME KING SIZE BRICKS; BRICK TYPE 1, WIRECUT FINISH	RUNNING BOND	SLATE GRAY

FENCE - 8' SINGLE WYTHE BRICK (DEVELOPER INSTALLED)

SCALE: NTS

D4-B

ELEVATION - SIDE

SCALE: NTS

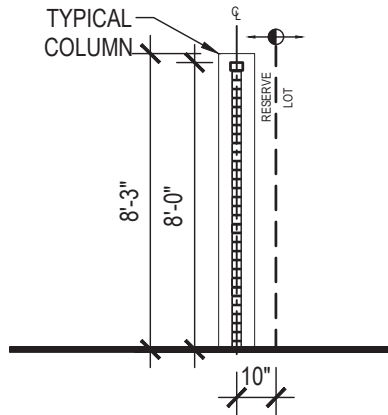

PLAN - TYPICAL COLUMN

SCALE: NTS

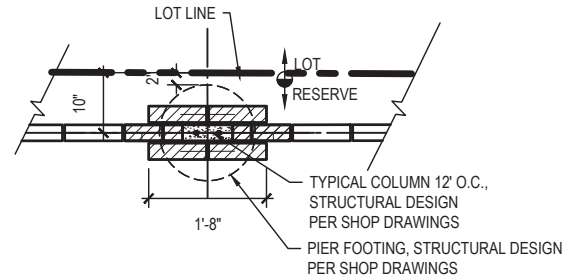

ELEVATION - FRONT

SCALE: NTS

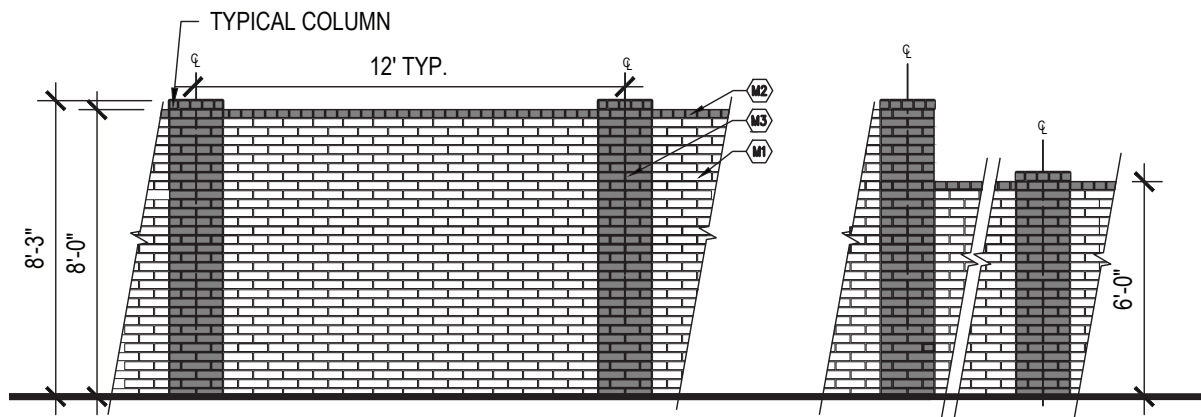

PLAN

SCALE: NTS

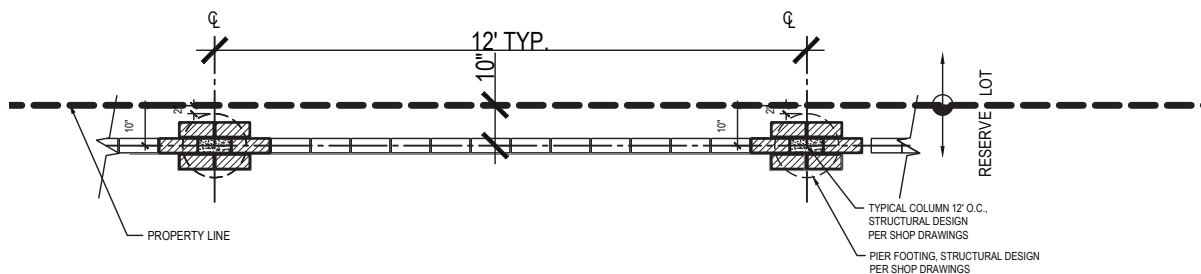

NOTES

1. ALL BRICK TO BE UTILITY KING SIZE BRICK FROM ACME WITH WIRECUT FINISH SEE MATERIAL KEY FOR FINISHES.
2. CONTRACTOR TO PROVIDE SIGNED AND SEALED STRUCTURAL DRAWINGS.
3. CONTRACTOR SHALL BE RESPONSIBLE FOR GRADING AT THE BOTTOM OF FENCE PANELS AND ADJACENT IMMEDIATE AREA. NO GAPS ALLOWED. TRANSITIONS TO ADJACENT GRADE SHALL BE GENTLE.
4. CENTER OF FENCE LINE SHOULD BE 6" OFFSET OUTSIDE FROM LOT LINE.
5. CORE HOLES SHALL NOT BE VISIBLE ON ANY EXPOSED SURFACE INCLUDING TOP HEADER COURSE AND TOP OF COLUMN NO GROUT CAPS ALLOWED.

MATERIAL KEY

KEY	MATERIAL	PATTERN	COLOR
M1	ACME KING SIZE BRICKS; BRICK TYPE 1, WIRECUT FINISH	RUNNING BOND	MARBLE GRAY
M2	ACME KING SIZE BRICKS; BRICK TYPE 2, WIRECUT FINISH, SOLID BRICK	HEADER COURSE	SLATE GRAY
M3	ACME KING SIZE BRICKS; BRICK TYPE 1, WIRECUT FINISH	RUNNING BOND	SLATE GRAY

FENCE - FENCECRETE - SMOOTH VERTICAL (DEVELOPER INSTALLED)

SCALE: NTS

D4-C

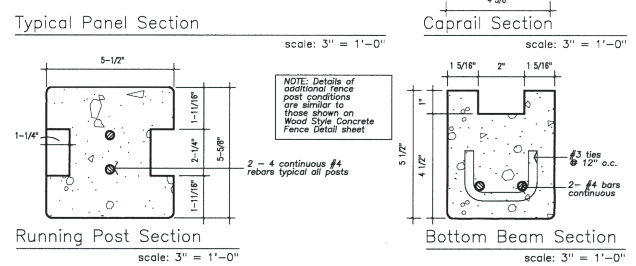
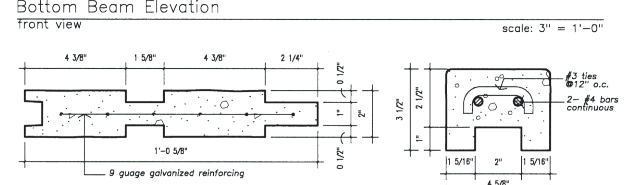
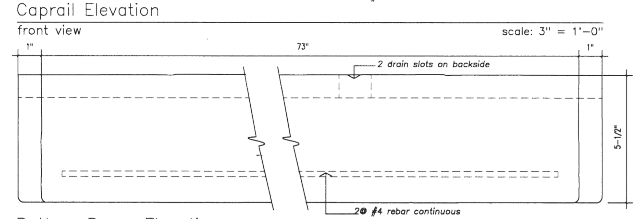
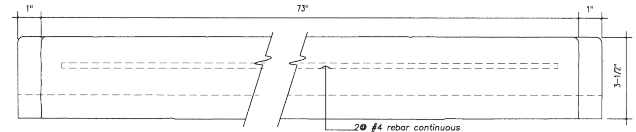
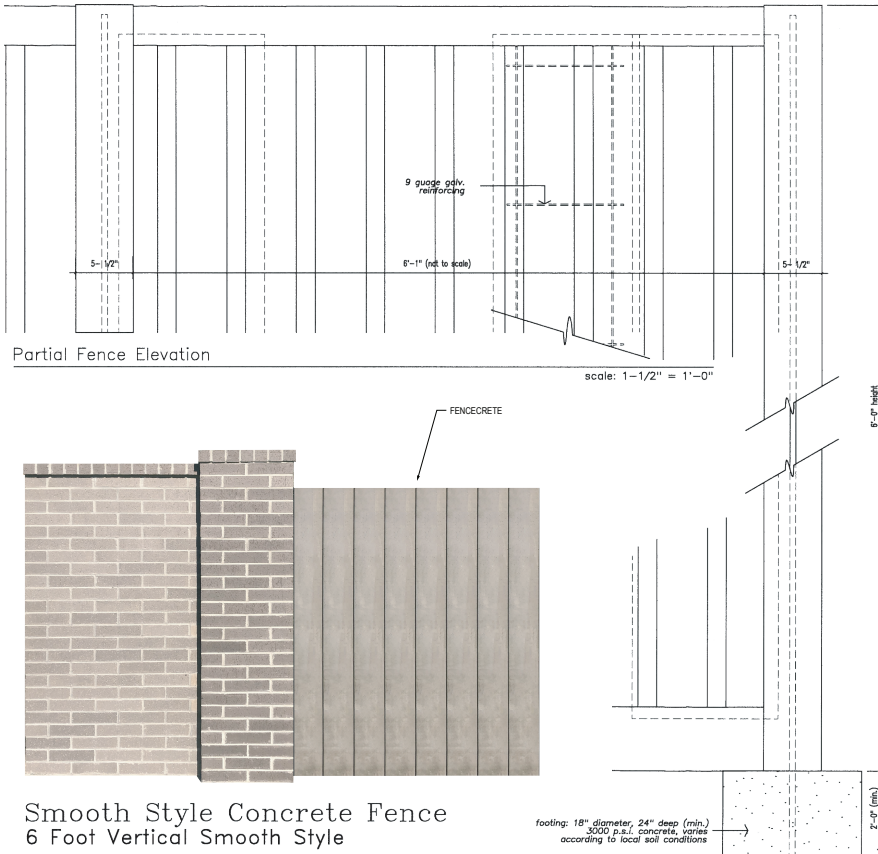

- notes:
- The column height is 8'-0". Fence height is 6'-0". This style is currently not available in any other heights.
 - All concrete shall be 5000 p.s.i.
 - All reinforcement shall be A.S.T.M. 615 grade 60. Special reinforcement is available upon special order.
 - Footing - 2 feet deep (min.) footing standard per column, 12" - 18" diameter. Depth and diameter can vary per local soil conditions.
 - Finish: All exposed sides.
 - Gates: Shall have additional steel supports adjacent to concrete columns.
 - All steel reinforcement is provided with steel spacers so as to allow for maximum concrete coverage.
 - A special silicone sealant is used to lock the caprail in place. This sealant requires special tools for removal.

We reserve the right to alter the design or specifications without incurring any obligation, all rights reserved.
Fencecrete America, Inc.

MANUFACTURER: FENCECRETE AMERICA
PRODUCT: SMOOTH STYLE CONCRETE FENCE
STYLE: 6 FOOT VERTICAL SMOOTH STYLE
COLOR: 'PEWTER'

NOTES

- CONTRACTOR TO PROVIDE SIGNED AND SEALED STRUCTURAL DRAWINGS.
- CONTRACTOR SHALL BE RESPONSIBLE FOR GRADING AT THE BOTTOM OF FENCE PANELS AND ADJACENT IMMEDIATE AREA. NO GAPS ALLOWED. TRANSITIONS TO ADJACENT GRADE SHALL BE GENTLE.
- CENTER OF FENCE LINE SHOULD BE 6" OFFSET OUTSIDE FROM LOT LINE.

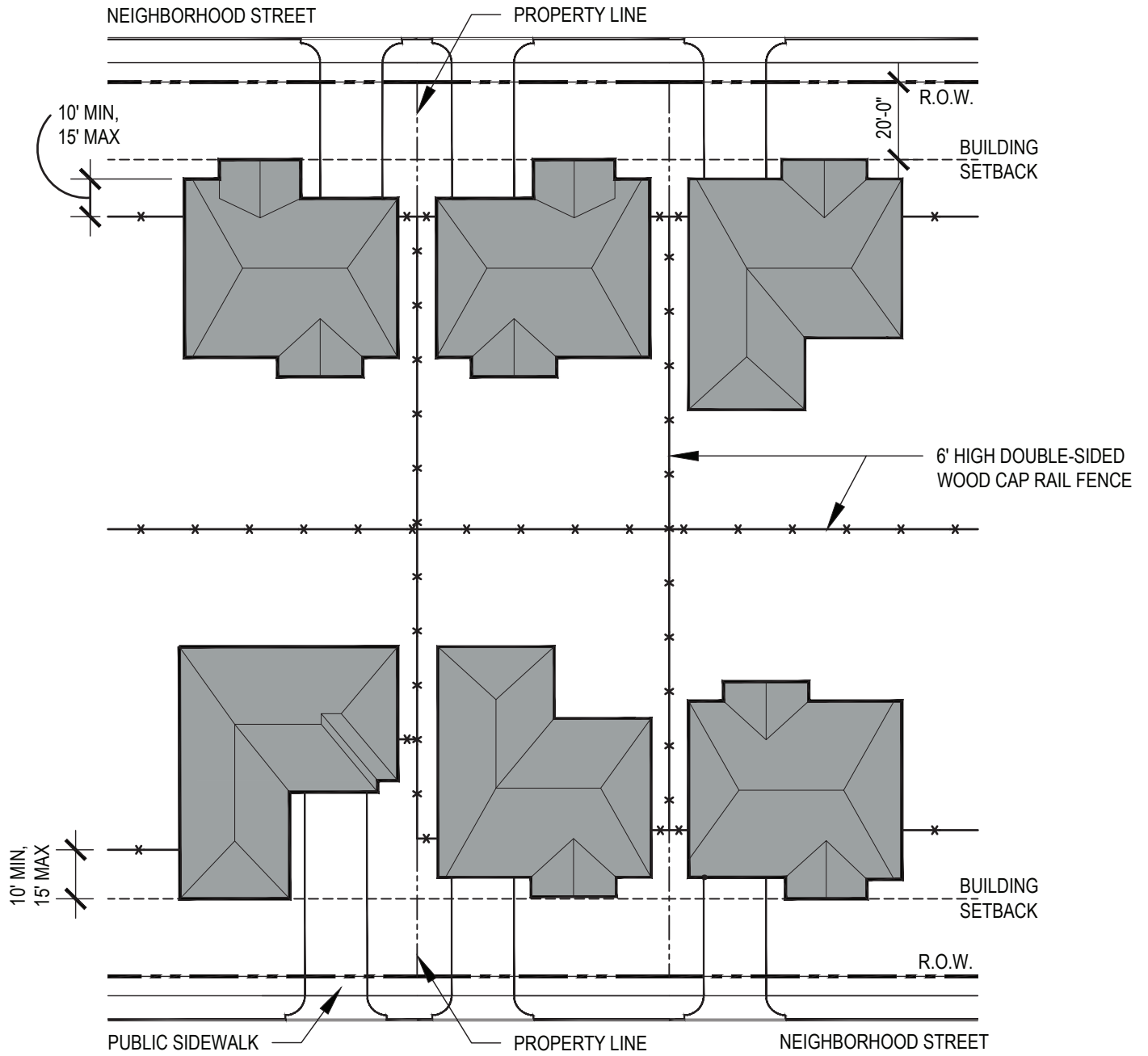

FENCING LEGEND

— x — x — x — 6 FT. HIGH DOUBLE-SIDED WOOD CAP RAIL

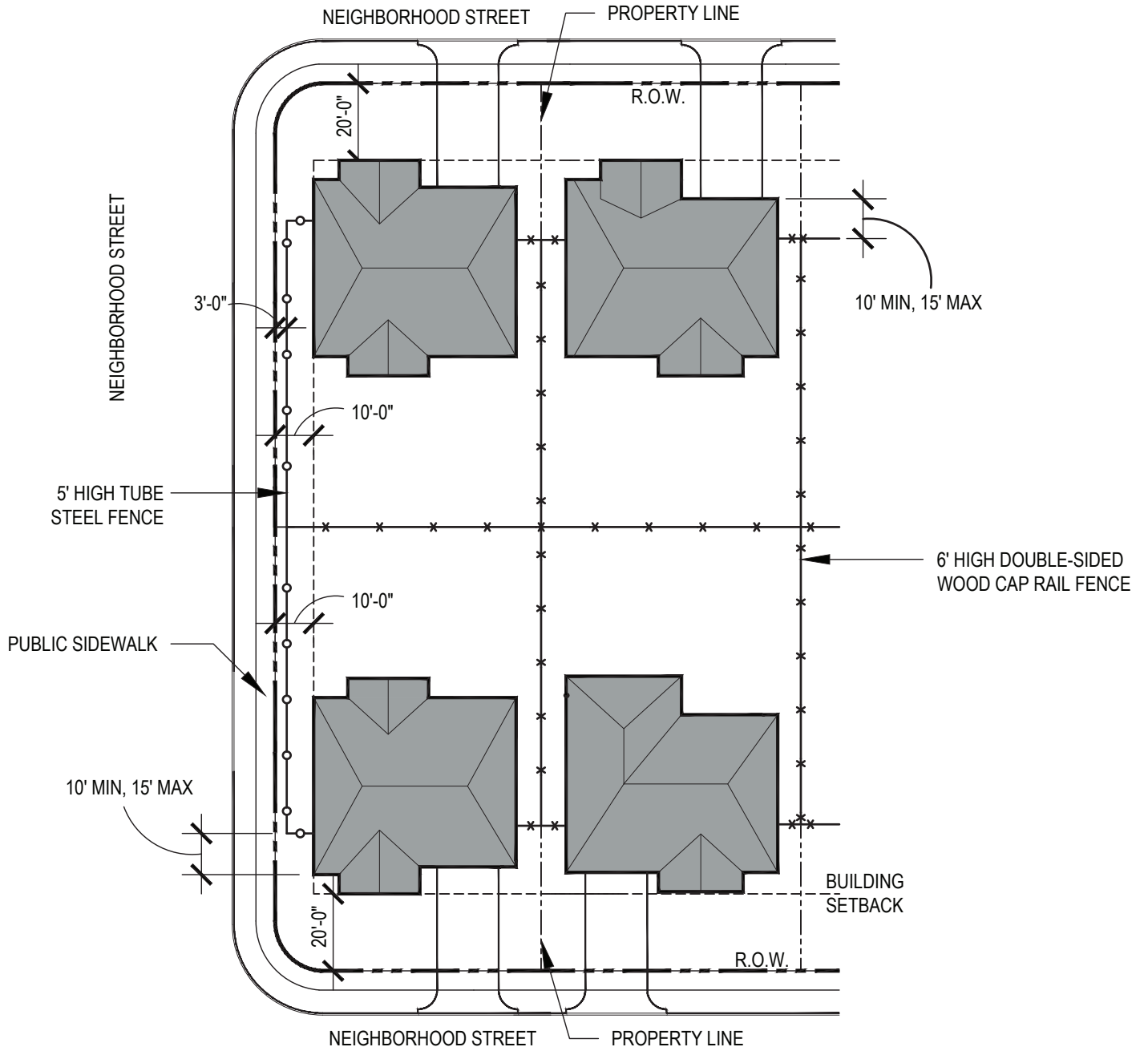

FENCING LEGEND

- * * * — 6 FT. HIGH DOUBLE-SIDED WOOD CAP RAIL
- o — 5 FT. HIGH TUBE STEEL

FENCING REQUIREMENTS - CORNER LOT (FRONT LOADED) - TYPICAL

SCALE: NTS

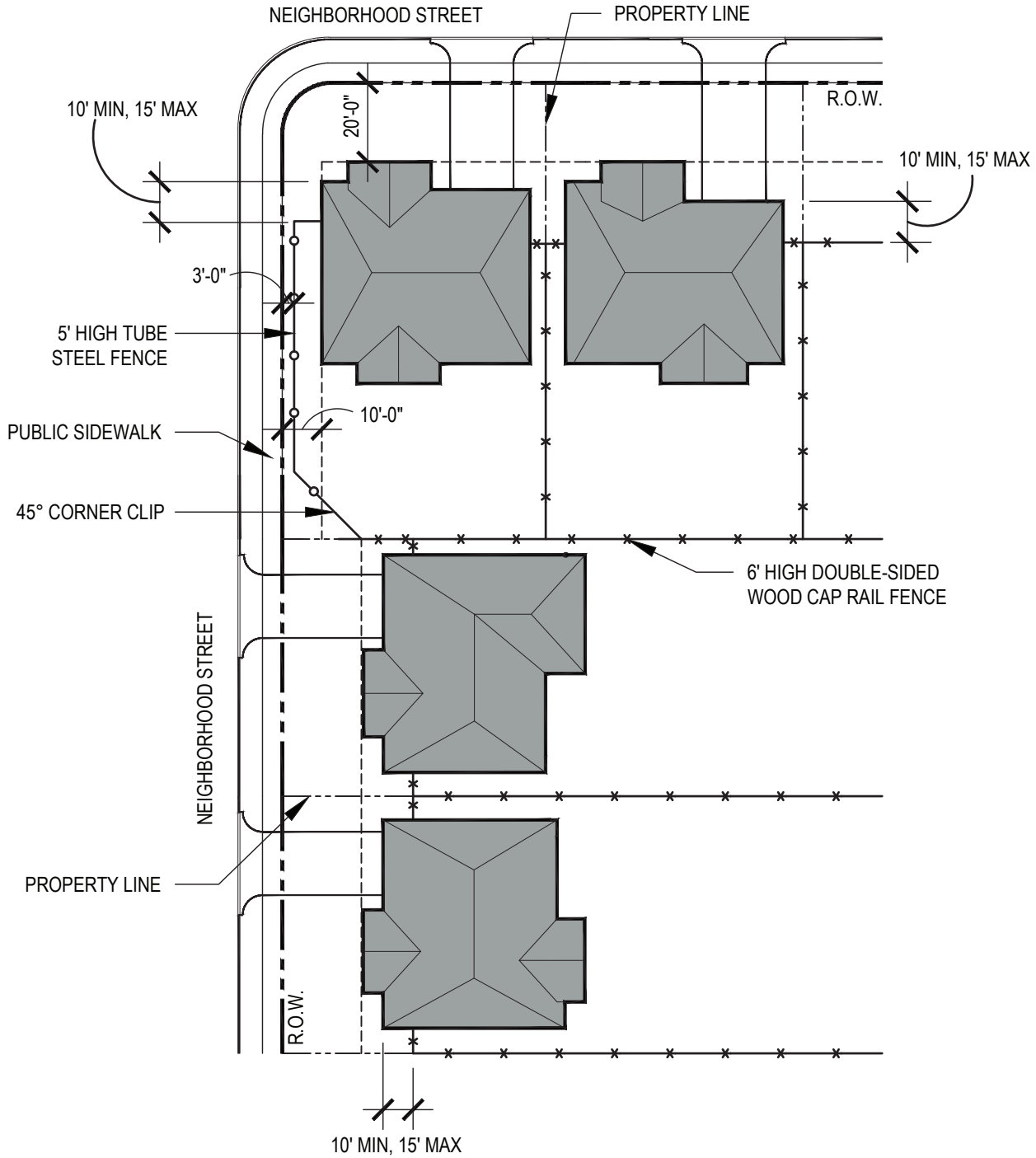

FENCING LEGEND

- x — x — x — 6 FT. HIGH DOUBLE-SIDED WOOD CAP RAIL
- o — o — o — 5 FT. HIGH TUBE STEEL

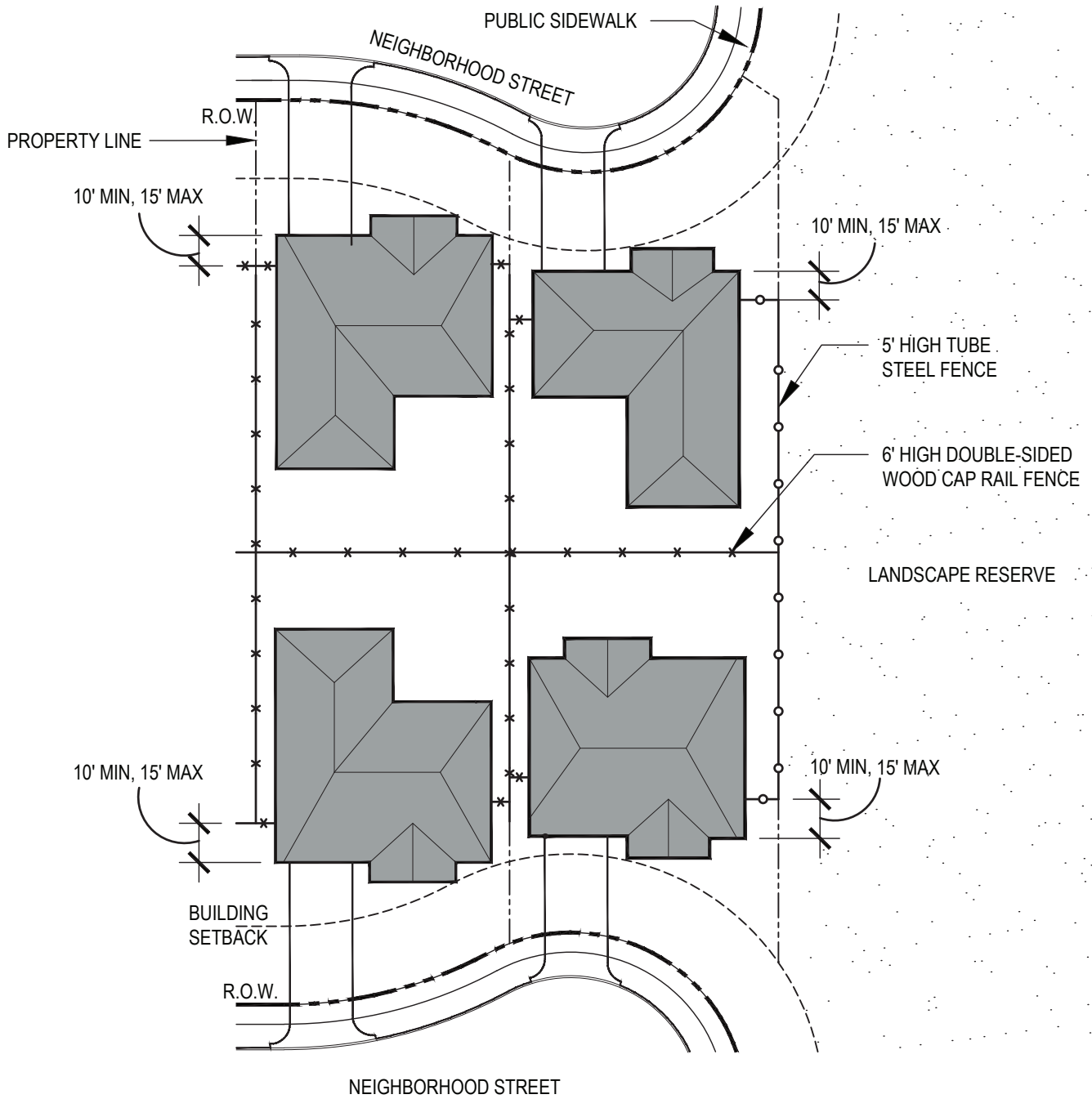

FENCING LEGEND

- x - x - x - 6 FT. HIGH DOUBLE-SIDED WOOD CAP RAIL
- o - o - o - 5 FT. HIGH TUBE STEEL

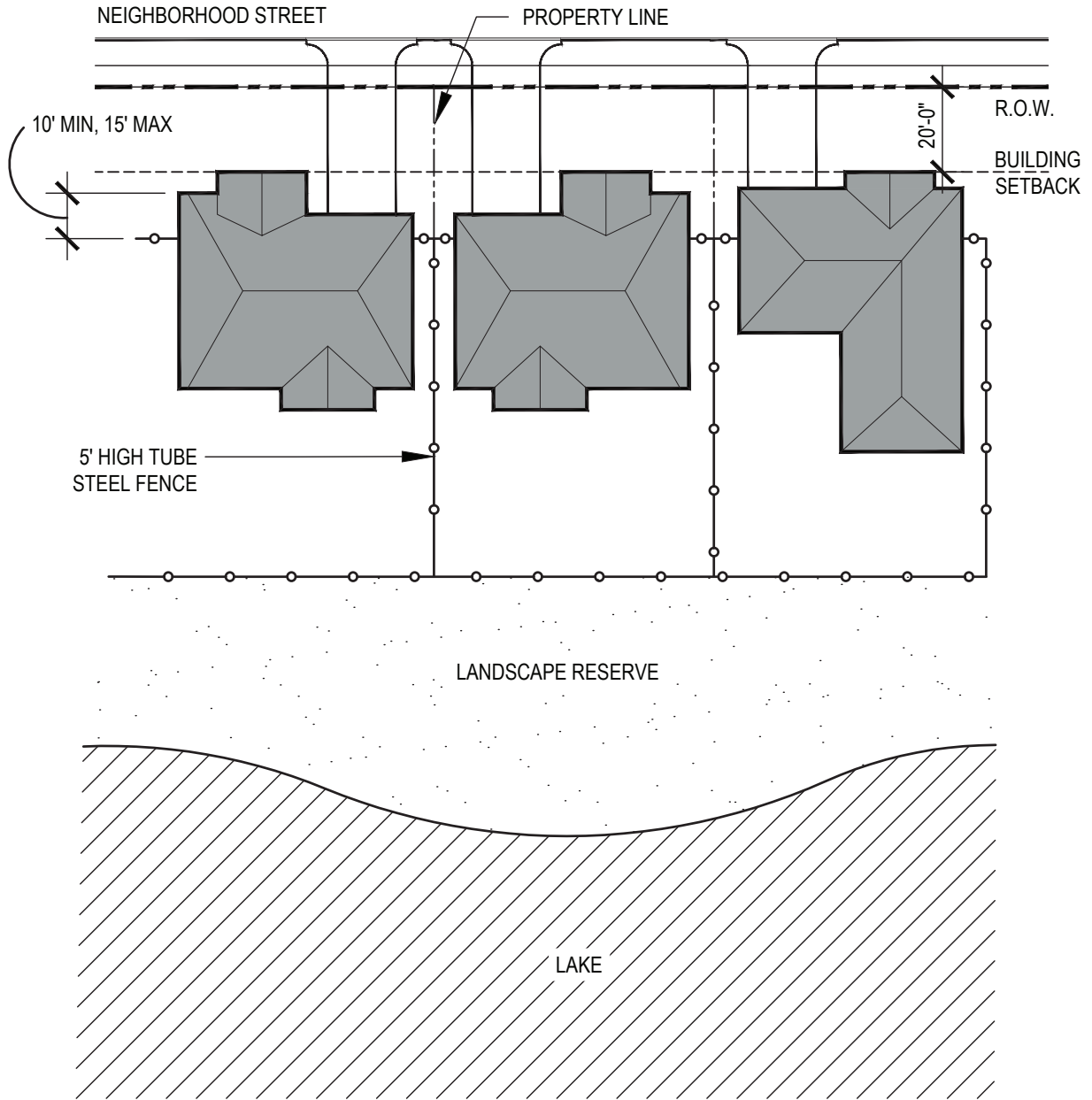

FENCING LEGEND

—○—○—○— 5 FT. HIGH TUBE STEEL

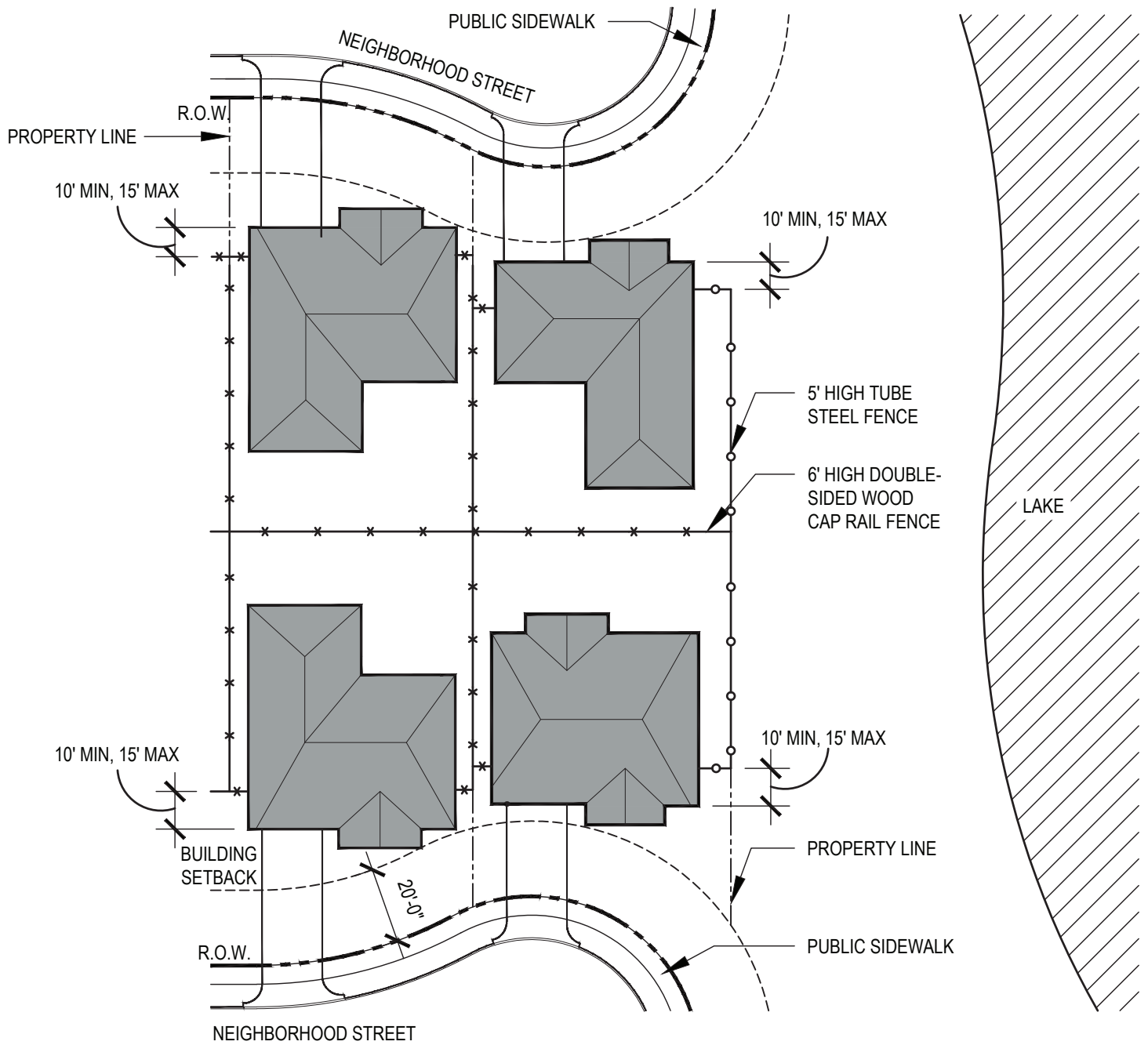

FENCING LEGEND

- x — x — x — 6 FT. HIGH DOUBLE-SIDED WOOD CAP RAIL
- o — o — o — 5 FT. HIGH TUBE STEEL

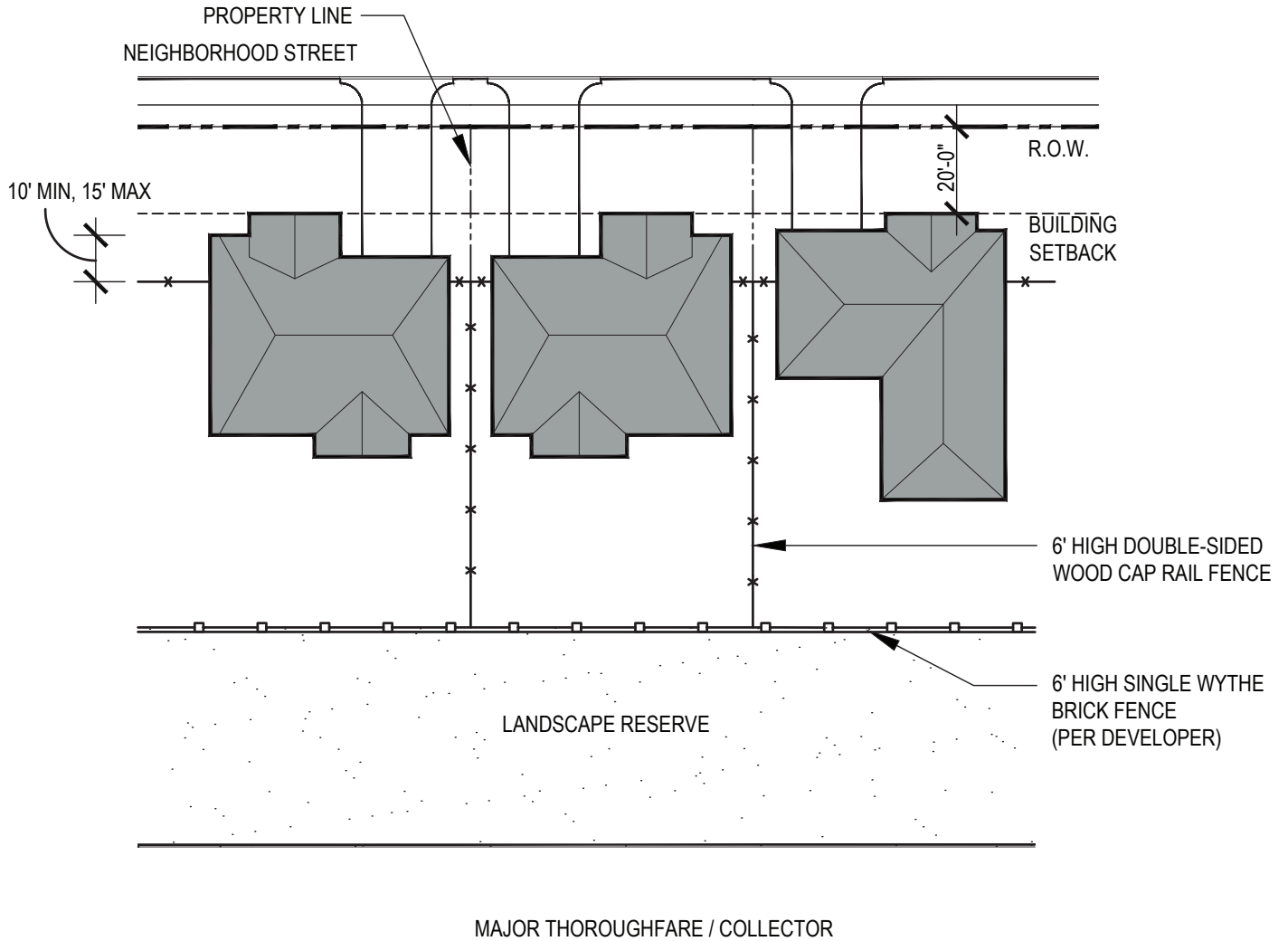

FENCING LEGEND

- * — * — * — 6 FT. HIGH DOUBLE-SIDED WOOD CAP RAIL
- ◻ — ◻ — ◻ — ◻ — 6 FT. HIGH SINGLE WYTHE BRICK (PER DEVELOPER)

ADDRESS PLAQUE DETAILS

SCALE: NTS

E1

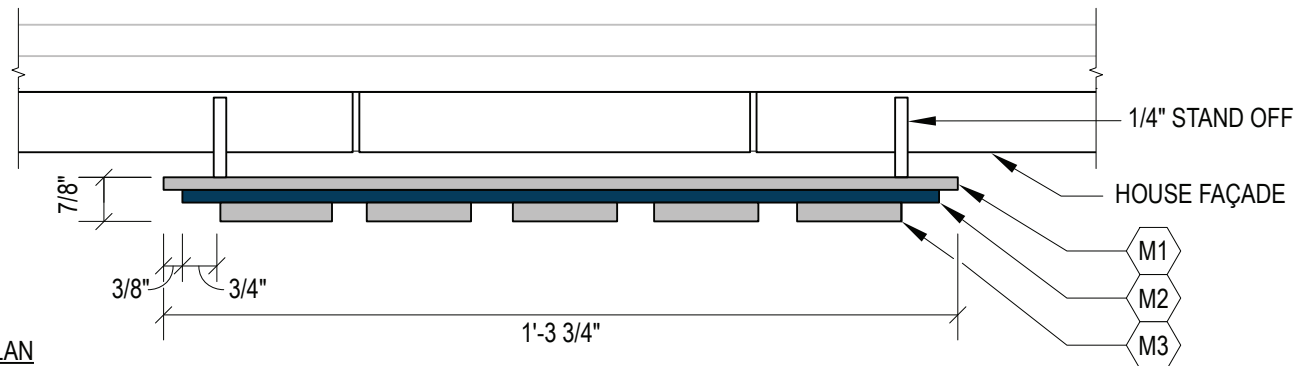
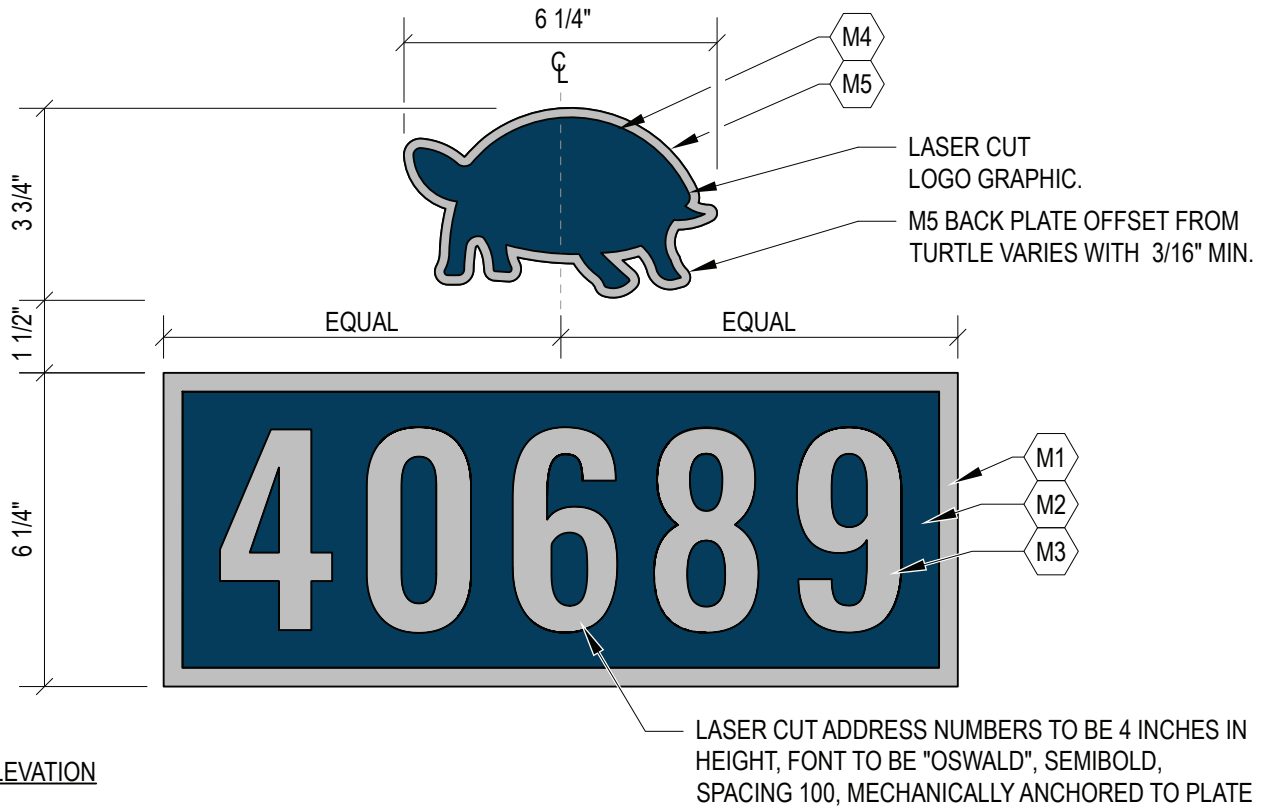

- ADDRESS PLAQUES SHALL BE MOUNTED ON THE GARAGE FAÇADE CLOSEST TO THE HOME.
- ADDRESS PLATE SHALL BE MOUNTED BETWEEN 4'-6" & 5' ABOVE FINISHED PAVEMENT OR GRADE AT THE SIGN.
- STAND OFF SHALL BE WELDED TO BACK PLATE, DRILLED AND EPOXIED INTO HOUSE FAÇADE.
- ADDRESS PLAQUE SHALL REMAIN THE SAME SIZE REGARDLESS OF LENGTH OF ADDRESS. CENTER NUMBERS.
- BUILDER TO CHOOSE THEIR OWN FABRICATOR OF CHOICE.

MATERIALS LEGEND		
KEY	DESCRIPTION	MATERIAL / COLOR
M1	1/4" ALUMINUM BACK PLATE	BRUSHED ALUMINUM
M2	1/4" ALUMINUM POWDER COATED	MATTE BLACK, RAL 5003, OR TIGER DRYLAC RUST FINE TEXTURE TO COMPLIMENT FAÇADE COLOR
M3	3/8" ADDRESS NUMBERS	BRUSHED ALUMINUM
M4	3/8" ALUMINUM TURTLE	COLOR TO MATCH M2
M5	1/4" ALUMINUM TURTLE BACK PLATE	BRUSHED ALUMINUM

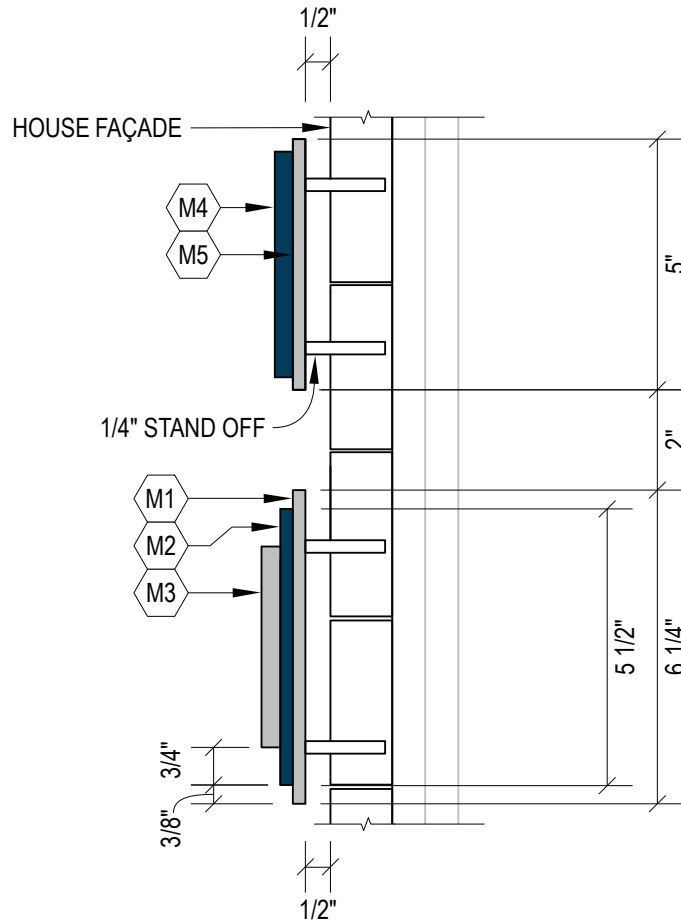

SECTION

- ADDRESS PLAQUES SHALL BE MOUNTED ON THE GARAGE FAÇADE CLOSEST TO THE HOME.
- ADDRESS PLATE SHALL BE MOUNTED BETWEEN 4'-6" & 5' ABOVE FINISHED PAVEMENT OR GRADE AT THE SIGN.
- STAND OFF SHALL BE WELDED TO BACK PLATE, DRILLED AND EPOXIED INTO HOUSE FAÇADE.
- ADDRESS PLAQUE SHALL REMAIN THE SAME SIZE REGARDLESS OF LENGTH OF ADDRESS. CENTER NUMBERS.
- BUILDER TO CHOOSE THEIR OWN FABRICATOR OF CHOICE.

MATERIALS LEGEND		
KEY	DESCRIPTION	MATERIAL / COLOR
M1	1/4" ALUMINUM BACK PLATE	BRUSHED ALUMINUM
M2	1/4" ALUMINUM POWDER COATED	MATTE BLACK, RAL 5003, OR TIGER DRYLAC RUST FINE TEXTURE TO COMPLIMENT FAÇADE COLOR
M3	3/8" ADDRESS NUMBERS	BRUSHED ALUMINUM
M4	3/8" ALUMINUM TURTLE	COLOR TO MATCH M2
M5	1/4" ALUMINUM TURTLE BACK PLATE	BRUSHED ALUMINUM

VIII. SECTION FENCE & DRIVEWAY LAYOUTS

Section Fence & Driveway Layouts are available at www.KenAnderson.com

IX. SUPPLEMENTAL GUIDELINES

All supplemental guidelines will be found on the pages that follow.

SUPPLEMENTAL GUIDELINES

CREEKLAND VILLAGE



(SECTIONS 14, 15, 16, 17, 18, 26, 40 & 41)

DISCLAIMER

Placement of these Supplemental Guidelines in the Bridgeland New Construction as well as confirmation of the accuracy and completeness of this document are to be solely determined by Bridgeland Development. All items and requirements not included in these Supplemental Guidelines will defer to the requirements of the Bridgeland New Construction Development Standards for Creekland Village.

Bridgeland – New Construction – Supplemental Guidelines (Creekland – Del Webb at Bridgeland)

I. ARCHITECTURAL STYLE

Creekland – Del Webb at Bridgeland will utilize a variety of architectural styles.

A. Individual Elements & Materials

1. Front Elevations

Front elevations may use Brick, Stone, Horizontal Lap Siding, Vertical Siding, Board and Batten, or Stucco Board. Mixed siding material on front elevations is approved if it follows the roof line. Mixed siding material on front elevations is not approved if the change in material does not tie into an architectural line/element. The use of wood, particle board, vinyl, aluminum or any sheet siding is prohibited. When there is a transition from one approved material on the front elevation to another approved material on a side elevation, the front material is not required to extend back on the side elevations. Material changes may occur on an outside corner.

2. Side Elevations

- a) The use of brick, stone, and siding is permitted on side elevations.
- b) When siding material is used on a side elevation, the following will apply:
 - i. No mixed use of siding is permitted, such as the combination of Board and Batten on the first floor wall and Lap Siding in a gable or wall above the B&B.
 - ii. If Board and Batten is used on front elevations, siding installed on the side elevations is permitted to be either Board and Batten or Lap Siding. When front elevations do not contain any Board & Batten, side elevations may not use Board & Batten.
 - iii. If Lap Siding is used on front elevations, siding installed on the side elevations is permitted to be Lap Siding, but not Board & Batten.
 - iv. If Vertical Siding is used on front elevations, siding on side elevations is permitted to be Lap Siding, Vertical Siding or Board and Batten.

3. Rear Elevations

The use of brick, stone and siding is permitted on rear elevations. When siding is used on rear elevations, the rear siding material must match the side elevations. On elevations where the front and side elevations are Board & Batten, the rear elevation must match material. If Lap Siding is used on side elevations, Lap Siding must be used on the rear elevation.

4. Private Walkway Accent Wall

The standard Private Walkway Accent Wall design will not be used in Creekland – Del Webb at Bridgeland.

Front private entry walks shall lead from the front main entry of the home to the driveway and be installed by Builder per the New Construction Supplemental Guidelines. Front entry walks may not be connected to the public sidewalk or the street curb. Continuous decorative pavers shall be used for the entire surface of the private front entry walks.

B. Square Footage

The allowable livable house square footage is as follows:

- **50' Lots:** 1,600 (Min.) – 3,400 (Max.) sqft.
- **65' Lots:** 2,100 (Min.) – 3,700 (Max.) sqft.

C. Fences

1. Fence Types*

Fence types used in these sections:

- Four (4') foot tubular steel fencing (Optional per Buyer, installed by Builder).
- Five (5') foot specialty wood (By Builder along Internal Collector and as specified per Exhibit).
- Six (6') foot Brick Thinwall (By Developer).

2. Locations*

a) Front Fences (Optional – Four (4') foot tubular steel)

When installed, front fences shall be set back, a minimum of ten (10') feet and maximum of fifteen (15') feet, from front corner face of the house unless there are conflicts with windows or other architectural elements of the house.

b) Side Fences (Interior) (Optional – Four (4') foot tubular steel)

When installed, side fences along interior property lines will be on the property line. Front fences, on the interior side of a corner lot, which are more than ten (10') feet long require a planting buffer.

c) Side Fence (Street Side – Corner Lot) (Optional – Four (4') foot tubular steel)

At the street side of corner lots, a minimum side fence setback of three (3') feet.

d) Rear Fences

- Optional four (4') foot tubular steel installed by Builder on the rear property line of interior lots.
- Five (5') foot specialty wood installed by Builder along collector streets and as specified by Exhibit.
- Brick Thinwall installed by the Developer on perimeter lots.

**(See "FENCE & DRIVEWAY LAYOUTS" at <https://www.KenAnderson.com/res-Bridgeland-Creekland> for the most up-to-date layouts, designations, and exhibits per Section.)*

II. Plan Repetition

A residential structure plan and elevation repetition should have the following separations:

- Same Plan, Same Elevation should have a minimum of one (1) full lot spacing between units.
- Same Plan, Different Elevation should have a minimum of one (1) full lot spacing between units.
- If the Plan is across the street, the first lot across the street is considered the first of the required separation lots.

PLAN	ELEVATION	STREET SIDE	FULL LOT SPACING
Same Plan	Same Elevation	Same Side	1
		Opposite Side	1
	Different Elevation	Same Side	1
		Opposite Side	1
Different Plan	Considered Same As	Same Side	1
		Opposite Side	1