

BRIDGELAND CENTRAL

EMERALD HEIGHTS

DESIGN
GUIDELINES
JUN | 2026

Howard Hughes

Howard Hughes Holdings

Bridgeland
23720 House Hahl Road
Cypress, TX 77433
281.213.1100



DTJ Design

3101 Iris Avenue, Suite 130
Boulder, Colorado 80301
303.443.7533
www.dtjdesign.com

OJB

OJB Landscape Architecture

2850 Clinton Drive, Suite 302
Houston, TX 77020
713.529.9919
www.ojb.com

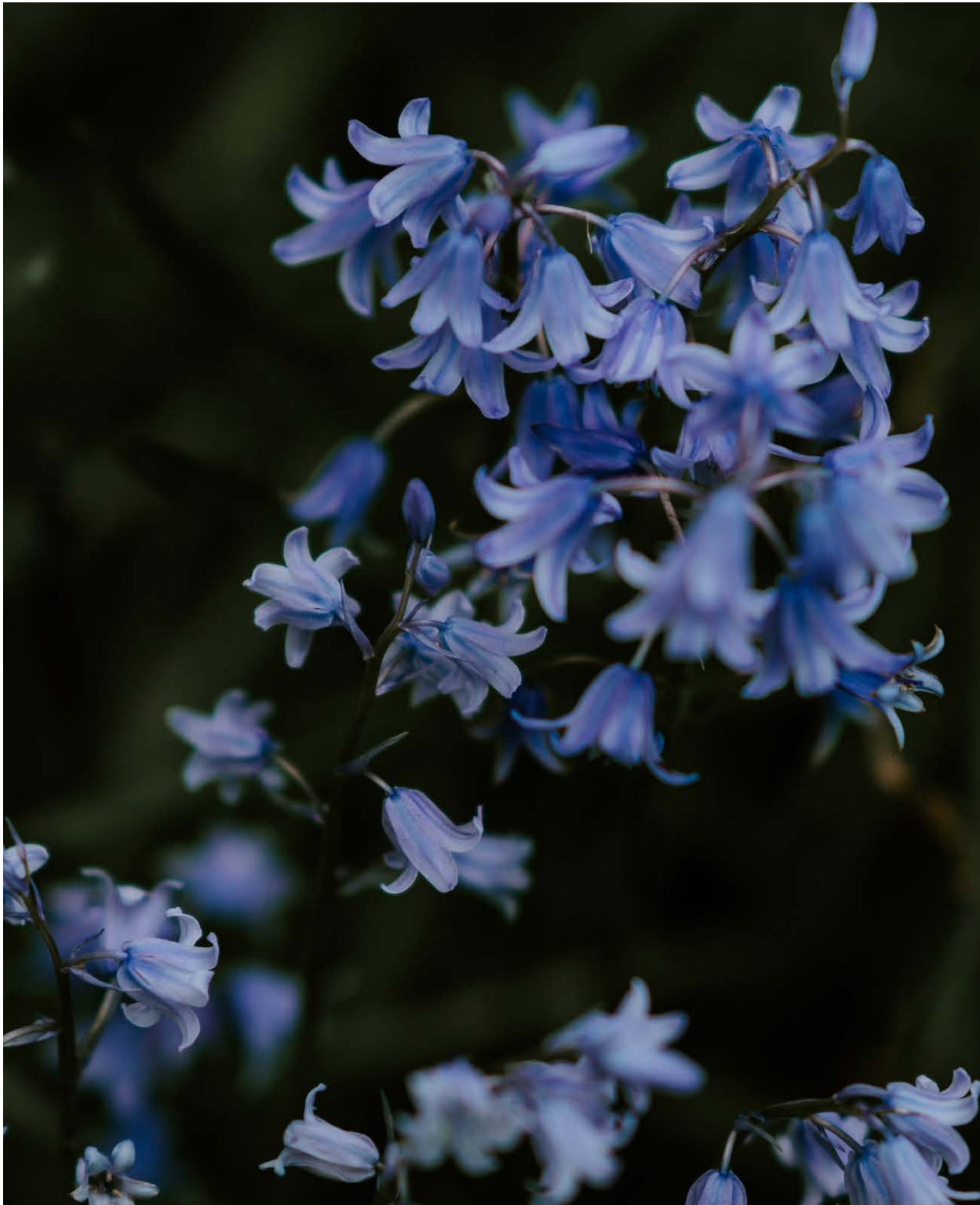

These design guidelines are intended to help direct qualified architects, owners, builders, and their representatives towards a unified community and architectural character defined as "Scandinavian Modern" and "Modern Farmhouse". These guidelines describe a framework and design aesthetic that promotes a consistent and recognizable solution. Creativity is encouraged to create a customized solution as long as it reflects the ideas and character described within the following pages.

These guidelines do not represent an exhaustive design methodology but rather are meant to be an inspiration for quality, thoughtful and innovative approaches to architectural styles within the boundaries of a consistent and recognizable "Scandinavian Modern" and "Modern Farmhouse" character.

No part of this document may be reproduced, stored in or introduced into a retrieval system, or transmitted, in any form, or by any means (electronic, mechanical, photocopying, recording, or otherwise) without prior written permission of the owner and designer (DTJ DESIGN Inc. and OBJ Landscape Architecture)



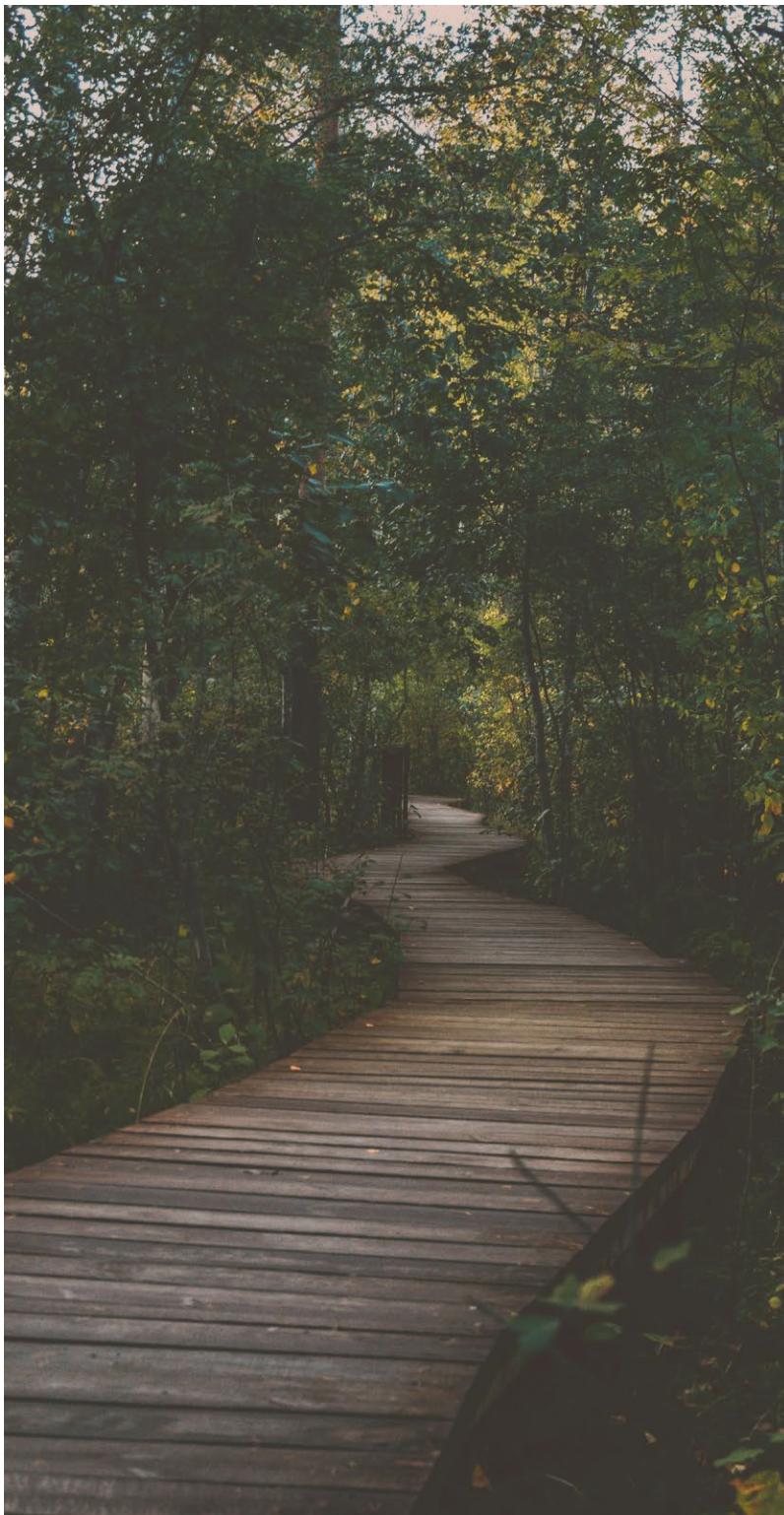

Introduction

6

- How these Guidelines are Organized
- General Provisions
- Site Overview
- Emerald Heights Site Plan
- Scandinavian Modern
 - Architectural Design
 - Design Spectrum
- Modern Farmhouse
 - Architectural Design
 - Design Spectrum

Architectural Design Criteria

19

- Scandinavian Modern
 - Style
 - Form
 - Fenestration
 - Structure Accents
 - Outdoor Areas
 - Materials + Color
- Modern Farmhouse
 - Style
 - Form
 - Fenestration
 - Structure Accents
 - Outdoor Areas
 - Materials + Color
- Universal Design

Site Plan and Lot Criteria

51

- Site Design Intent
- Bridgeland Masterplan
- Unique Site Conditions
- Front load Lot Requirements
- Rear load Lot Requirements
- Street Section
 - 60' R.O.W.
 - 50' R.O.W.
 - Alley

Landscape Design Criteria

67

- Landscape Character
- Landscape Image
- Integration + Transition
- Landscape Requirements
 - Front Load
 - Rear Load
 - Lot Responsibility
- Fencing + Gates
- Fundamental + water conservation
- Site Improvements
- Planting list

Design Review Process

95

- Procedures & Submissions

HOW THESE GUIDELINES ARE ORGANIZED

Introduction

The introduction component provides the purpose and focus of Bridgeland Central Emerald Heights Design Guidelines. This section is the foundation of the document and contains information related to design intent and character.

Architecture Design Criteria

This section describes the architectural image for Emerald Heights, derived in direct response to physical and climatic influences that reflect an urban environment. Architectural guidelines have been drafted to assist architects and builders in designing architecture in which the **building mass, roof form, architectural elements, materials, and colors** are appropriate for Bridgeland Central Emerald Heights.

Site Plan & Lot Design Criteria

Site planning guidelines for Emerald Heights are designed to promote a vibrant and interesting character and ambiance for this planned community through the intentional siting and orchestration of homes within this unique environment. The site planning section includes creative design criteria while balancing new development and the creation of an interesting community fabric.

Landscape Design Criteria

This section provides specific guidelines that have been established to promote planting designs that are well adapted to the region, resulting in indigenous landscapes that grow and function utilizing less energy, water, fertilizer, and maintenance. Another major objective of this section is to assure that individual lot landscapes harmonize with adjacent lots and open space areas, promoting a cohesive and flowing relationship.

Landscaping requirements are extensive and larger plantings may be required at specific locations fronting the master developer rights of way, open space reserves and spine roads. Lot owners are strongly advised to review these requirements in advance of construction of their parcel(s) and to budget approximately 5% or more of their total construction budget to landscaping costs.

Additionally, within the landscape section, these design guidelines provide prototype options for interior yard designs the builder(s) may chose to offer as upgrades for individual units.

Design Review Process

The Design Review Process is an integral part of ensuring that Bridgeland Central Emerald Heights is developed as a comprehensive and intuitive community. This section outlines the process and any requirements for builders within Emerald Heights.

GENERAL PROVISIONS

Who uses These Guidelines

We believe that the physical appearance of the site, architecture, and landscape is critical to the success of any community. Achieving a healthy and vibrant image is the goal of these guidelines. These guidelines advocate a strong and consistent community design vision at Bridgeland, with architecture and landscaping both fresh and timeless. To that end, we have established this Design Guideline document to assist the architects, owners, builders, and their representatives in creating residential homes and landscapes that are consistent with this goal.

Amendments & Supplements

This Bridgeland Central Emerald Heights Design Guideline document may, from time to time, be amended or supplemented by the Master Developer at its sole discretion. Any such amendments shall be applicable to all development plans that are subsequently submitted for review and approval to the Master Developer and Architecture Review Committee ("ARC").

Approvals

Unless otherwise explicitly provided herein to the contrary, all approvals shall be in writing and may be granted or withheld at the sole discretion of the Master Developer or ARC. Any approval pursuant to these Design Guidelines does not constitute a warranty, assurance, or representation by the approving party; and the approving party shall have no liability as a result of such approval.

Waivers

The Master Developer (The Howard Hughes Holdings) or the ARC shall have the right, from time to time, to waive, at its sole discretion, any provisions of this Design Guideline document as may be applied to any specific site, architectural, or landscape plan. No such waiver shall be construed or held to be a waiver of any provisions of this Bridgeland Central Emerald Heights Design Guideline document, or of the same provisions as to any other party.

Regulation Compliance

In addition to these Guidelines, builders and lot purchasers (and their consultants) at Bridgeland Central are expected to meet all the criteria established by both the overall Bridgeland Community and Harris County, Texas.

All development within the Bridgeland Central Emerald Heights shall comply with the codes and regulations of all Local, State, and Federal bodies and agencies, including, but not limited to, Bridgeland Guidelines, as well as the Harris County, Texas building codes. All development shall also comply with the Declaration of Covenants, Conditions, and Restrictions (CC&R's) adopted for Bridgeland.

The Bridgeland Central Emerald Heights Design Guideline document may be more restrictive than, but does not supersede or modify any existing City, County, or State codes or ordinances. In the event of conflict or discrepancy, or for subjects not addressed herein, the most restrictive standards shall apply.

SITE OVERVIEW



EMERALD HEIGHTS SITE PLAN



SCANDINAVIAN MODERN ARCHITECTURAL DESIGN



SCANDINAVIAN MODERN

Scandinavian Modern Architecture is characterized by its clean and minimalist design, emphasizing functionality, a strong connection to nature, and sustainability. A hallmark of this style is the clear articulation of building massing, each volume is intentionally expressed using a single, consistent material. This approach strengthens the purity of the design, heightens visual clarity, and reinforces the architectural character of the structure. Key architectural details include the use of natural materials such as wood and stone and large windows for abundant natural light. The integration of glass, pivot doors, and large windows contributes to a sense of openness, while flat facades, symmetry, and innovative angles enhance the overall aesthetic.

Key Elements:

- 1 Black Window Frames
- 2 Min 10:12 Gable
- 3 Min 2:12 Awnings
- 4 Flat Projections/Pop Outs
- 5 Large Windows with no divided light
- 6 Neutral tone and simple material with wood accents
- 7 Style appropriate door is unique to this style and painted a neutral tone

SCANDINAVIAN MODERN DESIGN SPECTRUM

In order to enhance the Bridgeland Core context, which will be urban in nature, the Scandinavian Modern style may be expressed in various ways to relate to a parcel's immediate context.



Traditional

The Classic style approach will include **clean lines, simple forms and massing** somewhat utilitarian in nature. More natural materials such vertical and horizontal siding. Natural to bold color pallet. The use of stone or masonry is minimized and usually reserved for accent walls.

Transitional

Transitional will add more modern elements, such as **clean and less textural material**, more flat roof sections, clean simple ornaments/columns, larger overhangs and rakes. More material changes with more metal accents.

SCANDINAVIAN MODERN



MODERN FARMHOUSE ARCHITECTURAL DESIGN



Farmhouse style architecture is easily identified by its simple, functional and well-proportioned forms that are box-like and have minimal ornamentation. These homes have historically reflected a two-story massing with predominantly gabled roofs, roof dormers, and covered porches that provide utilitarian spaces without the extensive use of embellishment and ornamentation. Hipped roof forms are occasionally incorporated at covered entries, especially on wrap-around porches.

Key Elements:

- 1 Front-facing gable incorporating a minimum 8:12 pitch.
- 2 Board and batten siding featured at street-facing elevations.
- 3 Front porches are encouraged.
- 4 Columns are 8x8 minimum (6x6 may be incorporated if unique from other styles) and showcase modern profiles.
- 5 Vertically proportioned windows.
- 6 Accent roof dormers or window awnings.
- 7 Fascia and soffit are painted the same darker tone color and provide high contrast to the monochromatic color palette.
- 8 Standing seam metal roof is encouraged at covered entries, roof dormer, and awnings.
- 9 Style appropriate door is unique to this style and painted an accent color.

MODERN FARMHOUSE DESIGN SPECTRUM

In order to enhance the Bridgeland Core context, which will be urban in nature, the Modern Farmhouse style may be expressed in various ways to relate to a parcel's immediate context.



Traditional

Elevation reflect more **historical** siding treatments and detailing. A monochromatic color palette allow for subtle enhancements like the **wrap-around porch, standing-seam metal roof, and window awnings** to become strong focal points that define this style.

Transitional

The overall form and massing is familiar, but **windows packages** are grouped together to become strong visual components, **column details** are refined and introduce modern profiles and connection details, and dark **fascia** provides **high contrast** to an otherwise monochromatic color palette that highlights the simplistic forms of this style.

MODERN FARMHOUSE

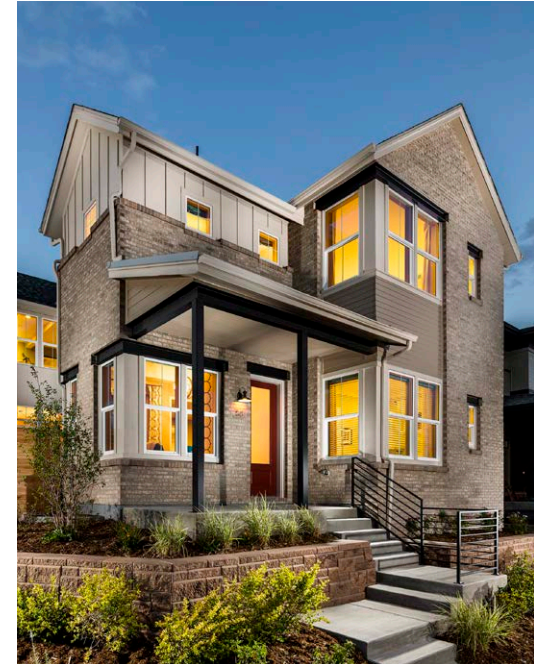





ARCHITECTURAL DESIGN CRITERIA

BRIDGELAND AND CENTRAL EMERALD HEIGHTS

SCANDINAVIAN MODERN STYLE

Image + Character

As a traditional neighborhood near the Bridgeland Central Core, Scandinavian Modern style embodies the essence of a timeless community with a modern twist. The clean, simple, light-weight, contemporary designs of Nordic architecture strengthen the sense of a cutting-edge community.

Scandinavian modern architecture emerged in the mid-20th century and is known for its simplicity, functionality, and connection to nature. It has influenced modern residential design, allowing it to merge with a multitude of other architectural styles to create unique variants.

Identifying Elements

A blend of agrarian and modern styles born out of Scandinavia, Denmark, and Norway. Characterized by clean lines, simple forms, and massing somewhat utilitarian in nature. It emphasizes natural elements within the vertical or horizontal siding and consists of a natural to bold color palette. The use of stone or masonry is minimized and used as a secondary material. Metal as a siding material is allowed upon approval.

Common Scandinavian Modern elements include:

- 1 Single material to be 80% dominant
- 2 Small entry porch
- 3 Monolithic color blocking
- 4 Smaller trim profiles
- 5 Natural wood siding
- 6 Wood or metal brackets
- 7 Wood or metal awnings/canopies
- 8 Large windows with no divided lights
- 9 Strong use of simplified gable form
- 10 Hygge - a design principle that prioritize warmth, comfort, and a sense of intimacy

SCANDINAVIAN MODERN



SCANDINAVIAN MODERN FORM

Roof Forms + Massing

Scandinavian Modern massing tends to be efficient to create usable interior volumes. Facade breaks, material changes, and secondary masses are required to create visual movement on the exterior architecture. Upper story masses shall appear lighter (with less bulk) than the lower story. Steep pitched roof forms are required for this style.

A visible main-body roof form shall be used in conjunction with complementary minor roof forms and elements. Minor roof elements such as gable ends and dormers shall be proportional to the spaces they cover and to the overall roof size and form.

The use of building projections, one story building elements, roof skirts, decks, and covered porches to soften facades is required on corner and enhanced elevations and is encouraged on rear elevations.

Roof + Overhang Details

Scandinavian Modern roof forms may take their inspiration from Nordic farm houses with steep roof pitches. It is important to ensure that the roof form reflects the overall massing of the building

Shallow roof overhangs should create strong shadow lines and complement the pitch and architectural style of the house.

Masonry

For Scandinavian Modern architecture, masonry shall be defined as brick, stone, stucco, and stucco board. While the use of masonry is encouraged, it shall only be allowed as secondary material. This architectural style is expressed most authentically when masonry serves as a complementary, secondary material rather than the dominant one. Prioritizing lighter, more natural materials for the main massing preserves the clean, minimal character that defines Scandinavian Modern design. No more than 20% of the entire house shall be masonry.

SCANDINAVIAN MODERN



Technical Requirements

Roof Slope(s):

Moderate to steep roof slopes for primary roof forms. Min 10:12

Steep Roof slopes form secondary roof forms. Min 12:12

Lower slopes for tertiary roof forms such as porches and awnings. Min 2:12

Flat roofs are encouraged but to be used sparingly.

Roof Overhangs:

Shallow overhangs. Max 6"

SCANDINAVIAN MODERN FENESTRATION

Fenestration, Windows, and Trim

Scandinavian Modern style elevations should employ large window packages and group windows symmetrically centered on masses. Shape and orientation of windows (composition and orientation of mullions and muntins) should emphasize form and mass of the building. Windows shall have minimal framing. Acceptable framing colors are almond or black. White frames are prohibited. Muntins may be asymmetrical but should have pattern and rhythm. Operable windows shall be single-hung, with exceptions for windows above kitchen sinks, bathtubs, and showers.

Entryways

The treatment of the main entry is important to the success of the design. The entry should be highlighted with architectural elements to draw attention. Front doors should employ neutral colors or black, natural materials, and simple designs to accentuate the entries of a building. Neutral color may be used to blend with the architecture to highlight the architecture without additional ornamentation. Front doors have windows unless accompanied by a side light.

Address markers should be neutral, modern, strong markers that accent the Scandinavian Modern style and shall be mounted to the front facade of these homes.

SCANDINAVIAN MODERN

Fenestration



Entryway



SCANDINAVIAN MODERN STRUCTURE ACCENTS

Building Projections

Buildings shall be articulated with appropriate projections that emphasize the style. Decks, balconies, and other projections shall use natural materials, details, and supports to accentuate the architecture and create focal points. Where appropriate, provide shade or overhead covering.

Columns + Beams

Scandinavian Modern style building are intended to appear light and delicate with clean lines; therefore, cantilevers are an appropriate alternative to columns and beams in some applications. The appearance of columns and beams can be bulky. Additionally, columns and beams may be used as accent elements by elongating or otherwise exaggerating the proportions to draw attention to the structure.

SCANDINAVIAN MODERN

Projections



Columns

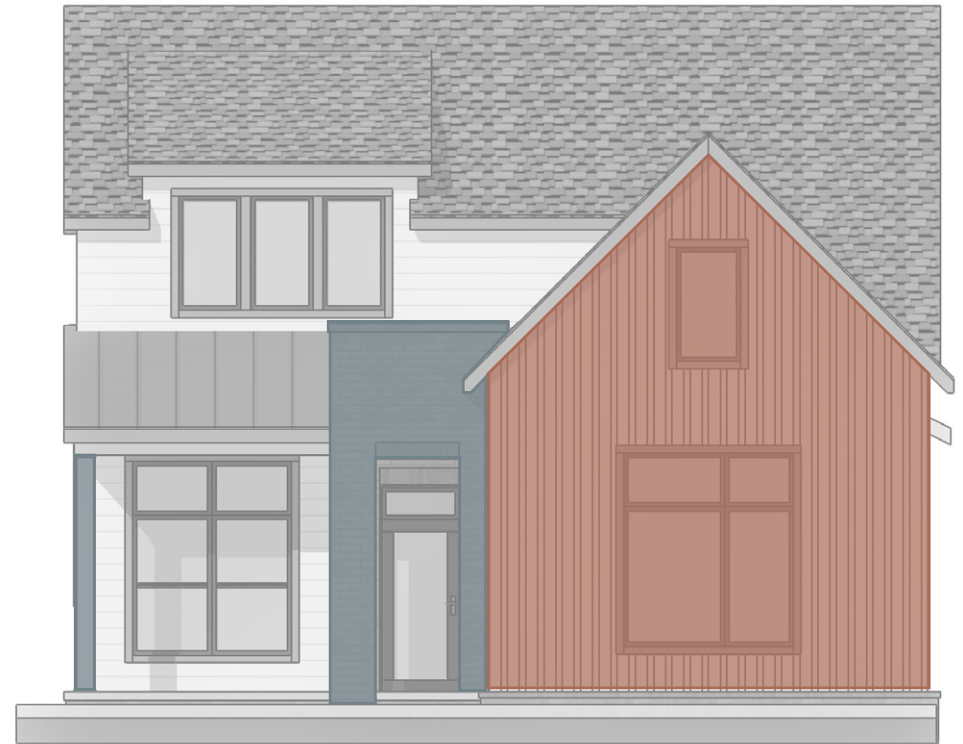

SCANDINAVIAN MODERN OUTDOOR AREAS

Decks, Porches, and Patios

Scandinavian Modern allows for the most flexibility for outdoor space integration. Primarily, porches and patios shall be fully or partially covered by an accent projection. Generally, decks, porches, and patios should be located and designed to be an extension of the buildings interior, creating ease of access and visual continuity. Materials, colors, and details should be consistent with the architecture of the building. See universal architectural requirements (end of this chapter) for additional dimensional requirements.

Railings + Posts

Railings and posts shall reflect the style of the building. In Scandinavian Modern applications, posts and railings shall be made of metal or wood and shall have minimal ornamentation. Details shall be clean and functional. Horizontal or vertical slat patterns are appropriate for Scandinavian Modern style. Additional details, like tie rods and other connection systems may be used as part of the overall composition.

Fences

There are two primary types of fences:

Standard Fences (Wood), and Open View Fences (Steel). (Refer to the landscape design criteria chapter for detailed information on fence dimensions and specifications.) Standard fences are typically constructed from wood with vertical or horizontal slat patterns, reflecting a clean, traditional look. Open view fences are often made from steel or other metal materials and are used at the side and rear of lots, particularly those adjacent to open spaces or scenic views, providing a blend of privacy and openness.

Address Markers

Address markers shall be peg-mounted (floating), brushed nickel or matte black numerals. The numbers shall read horizontally (not stacked or rotated). Placement shall be within 2' of door or on entry columns/face of wall of front patio structure.

Numerals shall be a minimum of 5" tall and no larger than 8" tall. The peg mounting shall allow for a minimum of 1/4" relief from the facade. Numeral font shall be san serif. When possible, the address shall be lit from above with a style-appropriate fixture.

SCANDINAVIAN MODERN

Decks



Railings



Fences



Address Markers



SCANDINAVIAN MODERN MATERIALS + COLOR

Fascia Application

Material application can drastically affect the appearance and authenticity of a style. For Scandinavian Modern style buildings, while structural elements and detail should be simple and clean, the application of fascia materials should have minimal ornamentation. Fasteners and other material anchoring details should be concealed where possible. Exceptions to this rule can be made in instances where the fasteners are part of an architectural enhancement (all exceptions are subject to review by the ARC).

Colors

The strategy for color application on Scandinavian Modern is to employ high-contrast hues (black/gray/beige/white) with cool colors and natural textures to add accents and break up massing. Bright colors and warm colors should only be used to highlight significant elements, such as doors.

Appropriate Materials

Siding:

- Wood (vertical or horizontal)
- Fiber Cement Panel
- Metal Panel (neutral color)
- Stucco / Stucco Board
- Cut Stone (Smooth face)
- Brick / Painted Brick*
- Smooth Hardie
- Vertical Board and Batten

Roofing:

- Black Asphalt Shingles**
- Standing Seam Metal

Columns:

- Wood
- Steel
- Concrete

Inappropriate Materials

Siding:

- White Painted Brick
- Vinyl

Roofing:

- Clay Tile
- Concrete Tiles

Columns:

- Vinyl
- Brick
- Stone

* Brick shall only be used as an accent material on secondary walls.

** Roofing color sample to be reviewed and approved by ARC.

SCANDINAVIAN MODERN

Technical Requirements

No material shall terminate on an outside corner. Materials on a public facade shall terminate on an interior corner.

For enhanced elevations, additional accent materials architectural features, and details contributing to the overall aesthetic are required. Enhanced elevations shall be subject to approval by the ARC.

Use of materials not listed in "approved materials" list is at the discretion of the ARC.

Siding Application

Board and Batten siding to be Cement Board with z-flashing at panel seams, painted to match.

Vertical siding to be 6" stained wood siding, or 1x6 vertical trim (cement board) over smooth cement board panel with 3¾" in between or 8½" off center.

Material Application



Metal Roof
Standing Seam



Wood

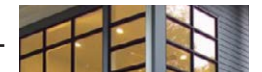

Accent Trim



Stucco (Smooth)

Color Application



Trim color



Primary Color



Accent Material color



Secondary color

MODERN FARMHOUSE STYLE

Image + Character

As a traditional neighborhood near the Bridgeland Central Core, the Modern Farmhouse style embodies the essence of a timeless community evolving organically. With its rustic charm and contemporary flair, this architectural approach imbues a sense of tradition while embracing modern sensibilities.

Modern Farmhouse architecture draws inspiration from the rustic charm of agrarian life, blending it seamlessly with contemporary design principles. Its clean lines, understated forms, and emphasis on natural materials evoke a sense of simplicity and authenticity.

Identifying Elements

The Modern Farmhouse style combines rustic elements with modern aesthetics. Characterized by clean lines and unpretentious forms, it often features vertical or horizontal siding adorned with natural materials. A subdued yet versatile color palette, ranging from earthy tones to bold accents, adds depth and character. While stone or masonry accents are sparingly used, metal siding may be incorporated with proper approval, contributing to the style's distinctive charm.

Common Modern Farmhouse elements include:

- 1 Use of Masonry accent
- 2 Small entry porch or veranda
- 3 Monolithic color blocking
- 4 Bold trim profiles
- 5 Natural wood siding
- 6 Exposed beams
- 7 Wood or metal awnings/canopies
- 8 Large windows with minimal divided lights

MODERN FARMHOUSE



MODERN FARMHOUSE FORM

Roof Forms + Massing

Modern Farmhouse massing tends to be efficient to create usable interior volumes. Facade breaks, material changes, and secondary masses are required to create visual movement on the exterior architecture. Upper story masses shall appear lighter (with less bulk) than the lower story. Pitched roof forms are required for this style.

A visible main-body roof form shall be used in conjunction with complementary minor roof forms and elements. Minor roof elements such as gable ends and dormers shall be proportional to the spaces they cover and to the overall roof size and form.

The use of building projections, one story building elements, roof skirts, decks, and covered porches to soften facades is required on corner and enhanced elevations and is encouraged on rear elevations.

Roof + Overhang Details

Modern Farmhouse roof forms may take their inspiration from farm houses with steep roof pitches. It is important to ensure that the roof form reflects the overall massing of the building

Shallow to moderate roof overhangs should create strong shadow lines and complement the pitch and architectural style of the house.

Masonry

For Modern Farmhouse architecture, masonry shall be defined as brick, stone, stucco, and stucco board. While the use of masonry is encouraged, it shall only be allowed as secondary material. This architectural style is expressed most authentically when masonry serves as a complementary, secondary material rather than the dominant one. No more than 20% of the entire house shall be masonry.

MODERN FARMHOUSE

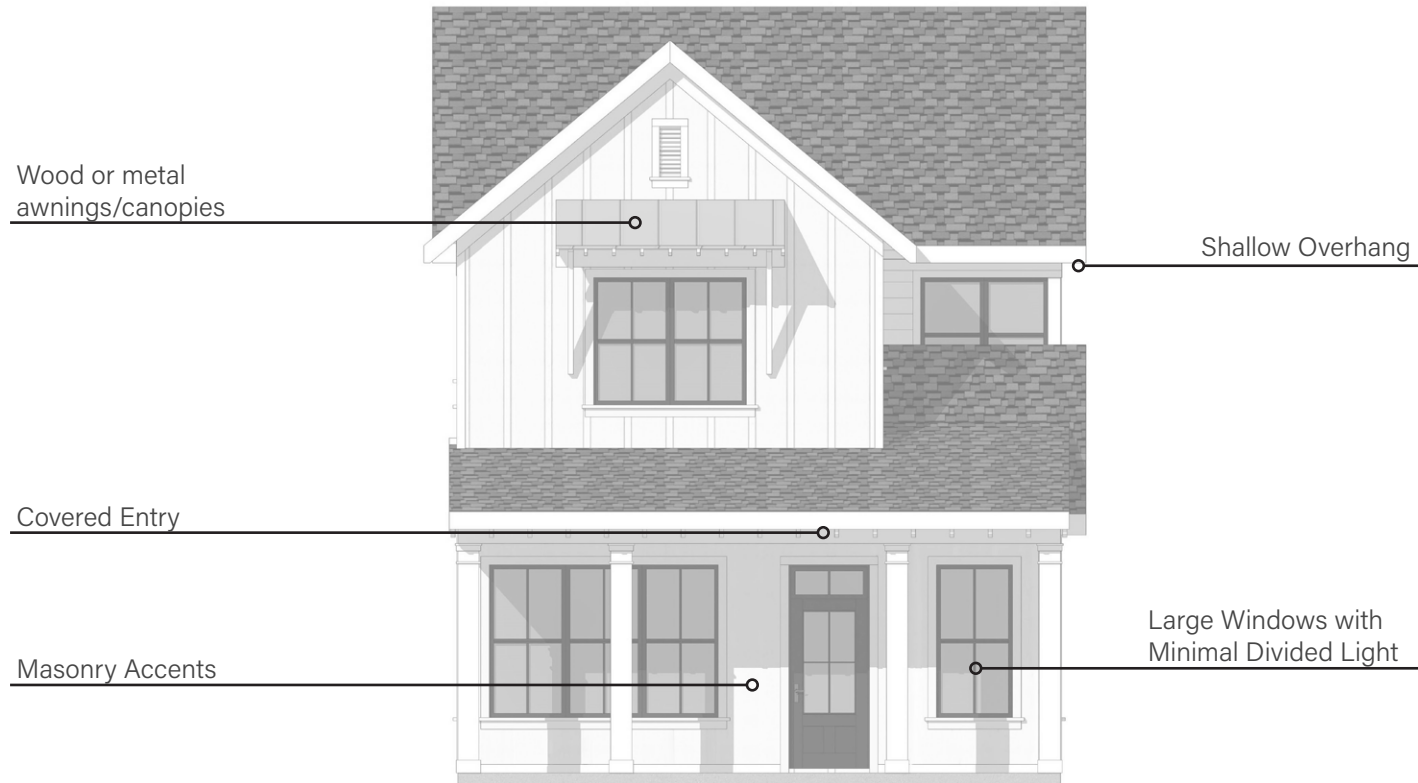

Technical Requirements

Roof Slope(s):

Moderate to steep roof slopes for primary roof forms. Min 8:12

Lower Roof slopes form secondary roof forms. 4:12 to 8:12

Lower slopes for tertiary roof forms such as porches and awnings. Min 2:12

Roof Overhangs:

Shallow to Moderate overhangs 12" - 18"

MODERN FARMHOUSE FENESTRATION

Fenestration, Windows, and Trim

Modern Farmhouse style elevations should employ a variety of window sizes, often featuring large, vertically oriented windows that allow ample natural light to flood the interior spaces. Windows are typically grouped to create a balanced and symmetrical look, emphasizing the form and mass of the building. Framing should be simple and substantial, often in materials like wood or black metal, which contrast nicely with the lighter exterior walls. Acceptable framing colors are black or white. Muntins are typically arranged in a traditional grid pattern, adding to the farmhouse charm and rhythm of the windows. Operable windows are generally double-hung or casement, with special considerations for areas such as above kitchen sinks, bathtubs, and showers, where functionality is crucial.

Entryways

The treatment of the main entry is crucial to the success of a Modern Farmhouse design. The entry should be highlighted with architectural elements such as gabled roofs, covered porches, or rustic wooden beams to draw attention. Front doors should be made from natural materials like wood or glass and employ simple designs, often featuring neutral colors like white, black, or muted earth tones to complement the farmhouse aesthetic. These doors frequently include windows or sidelights to enhance the welcoming feel.

Address markers should be simple yet strong, crafted from materials like metal or wood, and mounted prominently on the front facade to accentuate the Modern Farmhouse style.

MODERN FARMHOUSE

Fenestration



Entryway



MODERN FARMHOUSE STRUCTURE ACCENTS

Building Projections

Buildings in the Modern Farmhouse style should feature projections that emphasize their rustic yet refined aesthetic. Decks, balconies, bay windows, and other projections should utilize natural materials like wood and stone, along with details that enhance the farmhouse charm. These elements should not only accentuate the architecture but also create focal points and functional outdoor spaces. Where appropriate, include features such as pergolas, overhangs, or gabled roof covers to provide shade and protection from the elements.

Columns + Beams

Modern Farmhouse style buildings are characterized by their timeless and sturdy appearance, often featuring exposed columns and beams. These structural elements should be made from wood or steel, with a preference for simple, clean lines that maintain the farmhouse's rustic yet elegant look. Columns and beams can be used as accent elements, with the proportions either elongated or otherwise emphasized to draw attention to the structure. Incorporating these elements can add visual interest and reinforce the traditional farmhouse aesthetic, while cantilevers can be used in some applications to provide a more contemporary twist.

MODERN FARMHOUSE

Projections



Columns



MODERN FARMHOUSE OUTDOOR AREAS

Decks, Porches, and Patios

Modern Farmhouse style emphasizes a seamless integration of outdoor spaces, maintaining a cohesive and inviting aesthetic. Porches and patios in this style are typically covered by gabled or hipped roofs that complement the primary structure's form and proportion, or by rustic wooden pergolas. Decks, porches, and patios should be designed as natural extensions of the interior spaces, ensuring easy access and visual continuity. The materials used are typically wood or composite with a natural finish, often painted in neutral tones or classic farmhouse colors like white, black, or barn red. See universal architectural requirements (end of this chapter) for additional dimensional requirements.

Railings + Posts

Railings and posts should align with the Modern Farmhouse style of the building. In this context, posts and railings are commonly made of wood, often painted or stained to match the building's trim. The design should be straightforward and functional, featuring clean lines and minimal ornamentation. Traditional vertical slat patterns or simple horizontal designs are most appropriate for this style. Additional details, such as X-shaped cross braces or wrought iron accents, can be incorporated to enhance the overall composition while maintaining the farmhouse charm.

Fences

There are two primary types of fences:

Standard Fences (Wood), and Open View Fences (Steel). (Refer to the landscape design criteria chapter for detailed information on fence dimensions and specifications.) Standard fences are typically constructed from wood with vertical or horizontal slat patterns, reflecting a clean, traditional look. Open view fences are often made from steel or other metal materials and are used at the side and rear of lots, particularly those adjacent to open spaces or scenic views, providing a blend of privacy and openness.

Address Markers

Address markers shall be peg-mounted (floating), brushed nickel or matte black numerals. The numbers shall read horizontally (not stacked or rotated). Placement shall be within 2' of door or on entry columns/face of wall of front patio structure.

Numerals shall be a minimum of 5" tall and no larger than 8" tall. The peg mounting shall allow for a minimum of 1/4" relief from the facade. Numeral font shall be san serif. When possible, the address shall be lit from above with a style-appropriate fixture.

MODERN FARMHOUSE

Decks



Railings



Fences

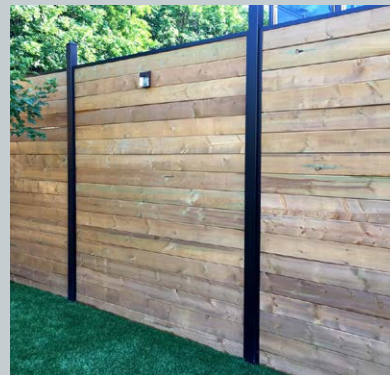

Address Markers



MODERN FARMHOUSE MATERIALS + COLOR

Fascia Application

Fascia materials plays a crucial role in maintaining the rustic and authentic appearance. Fascia should typically be made of wood or composite materials that mimic wood, often painted in neutral tones such as white, black, or natural wood stains. The design should be straightforward and clean, with minimal ornamentation to reflect the simplicity of the farmhouse aesthetic.

Fasteners and other material anchoring details should be concealed where possible to maintain a clean and polished look. Visible fasteners may be used if they serve as part of an intentional architectural enhancement, such as rustic iron nails or bolts that contribute to the farmhouse charm.

Colors

The color strategy for Modern Farmhouse style focuses on employing a palette of neutral, earthy tones with high-contrast hues to highlight architectural features and break up the massing. Common colors include:

- Neutrals: Whites, creams, and light grays are often used for the main body of the house.
- Contrasts: Black or dark gray accents can be used for trim, window frames, and doors to create striking contrasts.
- Natural Textures: Wood elements, whether stained or left natural, add warmth and texture to the design.

Bright colors and warm hues should be reserved for highlighting significant elements, such as front doors or shutters, providing a pop of color that draws attention without overwhelming the overall aesthetic. These accent colors can include muted reds, blues, or greens that complement the neutral palette and add character to the home.

Appropriate Materials

Siding:

- Wood (vertical or horizontal)
- Wood (Board-and-batten)
- Wood (Shiplap)
- Cut Stone (Smooth face)
- Painted Brick
- Natural Brick
- Fiber Cement Panel
- Composite Siding
- Stucco Board

Roofing:

- Metal Roofing
- Black Asphalt Shingles*

Columns:

- Wood
- Steel
- Composite

Inappropriate Materials

Siding:

- Aluminum
- White Painted Brick
- Vinyl

Roofing:

- Clay Tiles
- Concrete Tiles
- Flat Roofing Materials

Columns:

- Vinyl
- Concrete
- Brick

* Roofing color sample to be reviewed and approved by ARC.

MODERN FARMHOUSE

Technical Requirements

Material Termination:

No material shall terminate on an outside corner. This helps to maintain a seamless and cohesive look. Materials on a public facade must terminate on an interior corner. This ensures a clean and polished finish where different materials meet. For enhanced elevations, additional accent materials architectural features, and details contributing to the overall aesthetic are required. Enhanced elevations shall be subject to approval by the ARC.

Use of materials not listed in "approved materials" list is at the discretion of the ARC.

Siding Application

Board and Batten siding to be Cement Board with z-flashing at panel seams, painted to match.

Vertical siding to be 6" stained wood siding, or 1x2 vertical trim (cement board) over smooth cement board panel with 8" in between or 16" off center.

Material Application



Shingles



Accent Trim



Masonry
(Fiber Cement Panel)



Wood
(Board and Batten)

Color Application



Trim color



Primary color



Secondary color



Accent material color

UNIVERSAL DESIGN

■ Side Architecture

- Side Architecture shall reflect continuity of style and avoid large blank walls
- Changes in facade materials shall be accompanied by changes in wall planes
- Wrap window treatments around corners

■ Covered Entries

- The front elevation should be composed to reflect the architectural style and seamlessly accommodate the entry.

■ Facade Enhancements

- Wrap corner with overhangs/awnings to pull style from the front elevation to side elevation
- Decorative railing and window trim should be apparent and match style

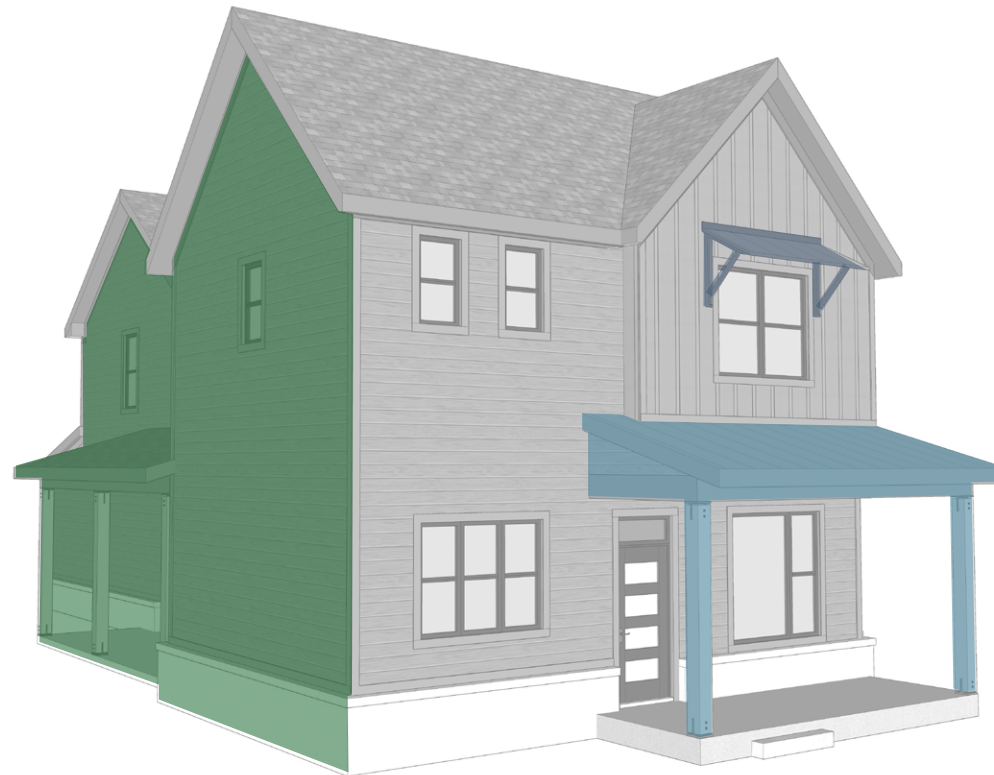

■ Integrating Front Porches & Entries

- Integrate steps and site walls to create interesting site elements. Return steps to a site wall where possible.
- Integrating stairs into planting beds or site walls will create an entry closer to the street blending private space and public space.
- If porch to adjacent grade is greater than 14", steps are required to be integrated (no "tack-ons").
- All steps shall tie into the front patio. Landings between steps are prohibited.

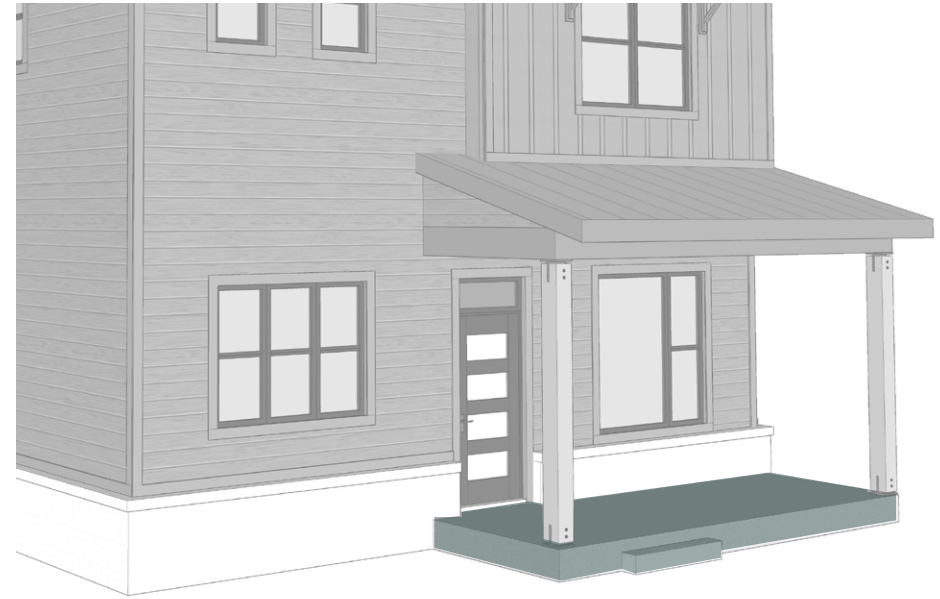

UNIVERSAL DESIGN

■ Facade Articulation

(on publically-visible elevations)

- A minimum of one window on each elevation shall be encouraged.
- All buildings shall require facade articulation on front and rear elevations to discourage a box-like appearance (side elevation articulation is encouraged).

■ Material Change

- Where materials occur at a corner of front elevation, they shall wrap the corner and terminate at an inside corner on the side elevation.

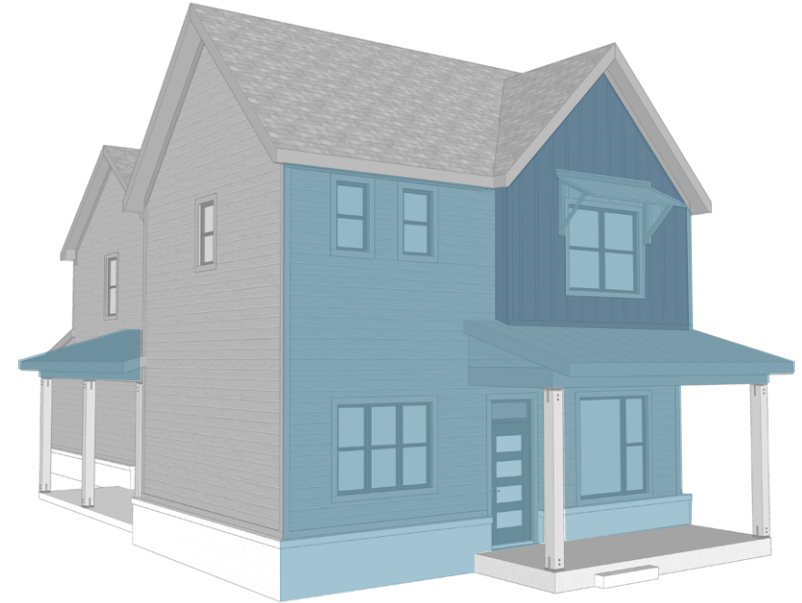

■ Building Materials

- All homes shall be constructed with a secondary material on all elevations. Example: wood panels (primary material), masonry (secondary material).
- Cladding dimensions from the front elevation shall be consistent for all elevations

■ Building Projections

- Projected elements shall be integrated with the main mass of the building in terms of materials, textures, proportions, and colors. Alternatively, elements designed to reflect a specific re-use character may be contrasting in color and/or materials.



UNIVERSAL DESIGN

■ Front Porches and Covered Entries

- A covered porch or covered entry compatible with the architectural style of the home shall be required.
- Covered porches (80 square feet or greater) shall be a minimum of eight feet deep.
- Covered entries are mandatory and shall be a minimum of 36 square feet and six feet deep.

Decks

- Decks shall be integral to the architecture of the house through column and railing details.
- Covered decks shall have roof forms consistent with the house.

■ Color and Materials

- On any structure, color and material variety shall relate to changes of structural elements, such as building base, facade, and roof. This creates a varied palette of colors and materials.
- The architectural style of the home requires window sash, mullions, and trim to be neutral colors or accent material to compliment primary structure.

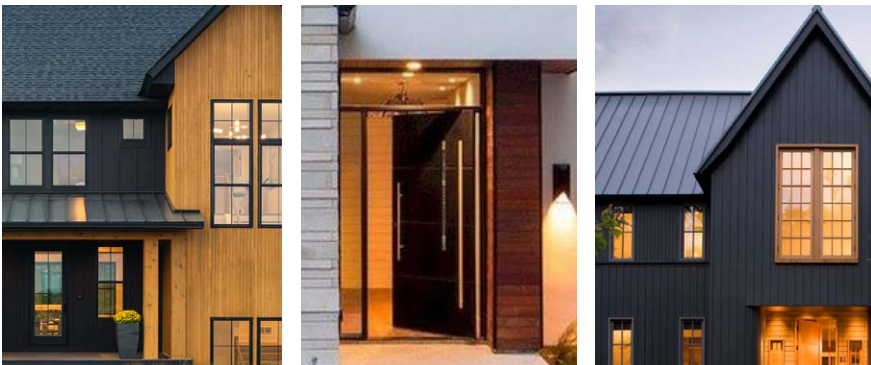
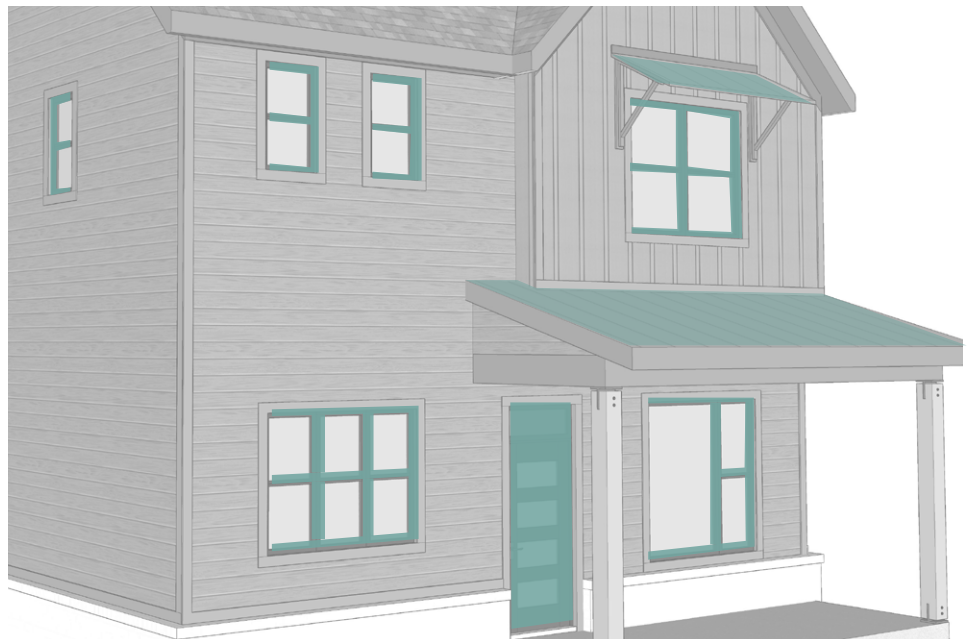
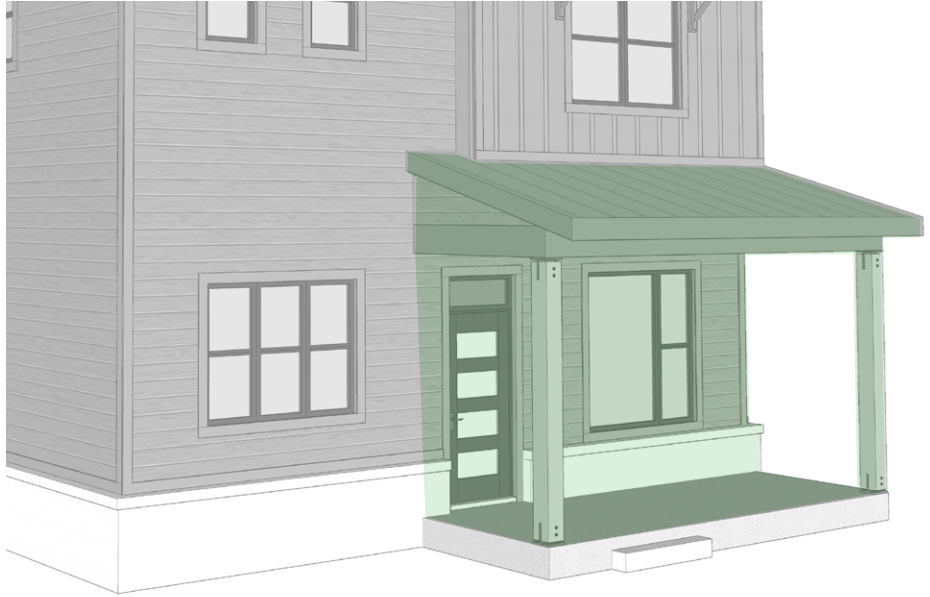

UNIVERSAL DESIGN

Plan Repetition

A home shall promote unified diversity by being compatible with neighboring houses. A combination of one and two story homes shall be mixed together along the streetscape, creating variety and visual interest. A color or material change does not constitute a change in elevation.

Building footprints and elevations shall be varied based upon the following requirements:

- If the plan is to be repeated with the same front elevation design on either the same side or opposite side of the street, it shall not occur more frequently than every third (3rd) consecutive lot. Thus, where this situation exists, at least two (2) other homes shall occur between the next repeated front elevations. Brick and trim color in this situation shall be different.
- If a plan is to be repeated with a different front elevation design on the same or opposite side of the street, it shall not occur more frequently than every second (2nd) consecutive lot. Thus, where this situation exists, at least one (1) other home shall occur between the next repeated floor plan with a different front elevation design. Brick and trim color in this situation shall be different.

Homes that front or visually face one another will be considered adjacent lots even if they are located on different streets or opposite block faces. A repeated plan with the same elevation will not be permitted in these situations simply because the homes front onto different streets. If the same plan is proposed in this condition, the builder will be required to select a different elevation and, if the overall appearance still reads as repetitive, the builder will be required to select a different plan/elevation combination.





In order to create variety along a street without requiring additional floorplans, use a mix-and-match approach including enhancements and alternative elevation styles.





SITE PLAN AND LOT CRITERIA

BRIDGELAND AND CENTRAL EMERALD HEIGHTS

SITE DESIGN INTENT

Bridgeland Central Emerald Heights is a neighborhood located within the overall Bridgeland Community. Emerald Heights offers many amenities including a large neighborhood park and connections to the lake extension corridor. The project site which these guidelines specifically address, is in the east portion of Bridgeland Central. The design of this neighborhood embraces a village style community with a Main Street, a central park and smaller lots. This site leverages straight-forward planning and traditional neighborhood design to create an intimate character that links into the overall Bridgeland Central vision.

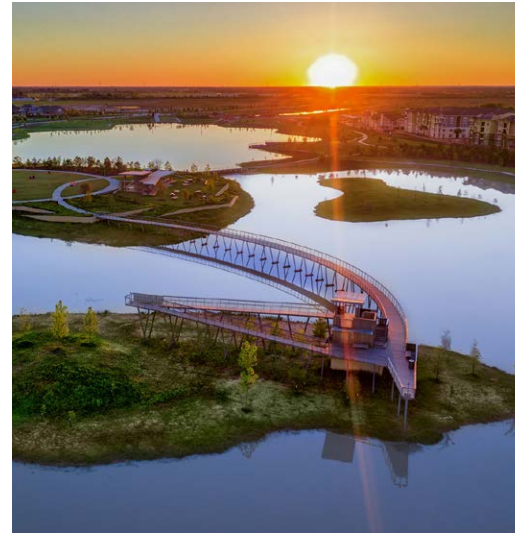

BRIDGELAND MASTERPLAN



UNIQUE SITE CONDITIONS



Side Architecture:



For locations where side architecture will be highly visible from the street or open space, design and aesthetic considerations should be made to ensure consistent appearance throughout the community. In these locations enhanced facade will be required.

R - "required" to meet enhanced side architecture.

P - "preferred" to meet enhanced side architecture requirements.

Side Architecture and Open Space:

For locations where side architecture will be adjacent to open space, the interface and aesthetic should be made to ensure privacy but also contribute to the quality of the space. In addition to augmented screening, in these locations enhanced facade and landscape treatments will be required.



Visual Terminus:

The street pattern creates visual corridors that guide the sight lines. Certain locations will implicitly become the focal points at the terminus of a street. In these locations enhanced facade and landscape treatments will be required and driveway/garage door locations should be located to the far side of the visual terminus.

Front Loaded Units on Corners:

The extra width in a corner lot creates opportunities to wrap the architecture around the corner. In these locations enhanced facade and landscape treatments will be required.

Linear and Public Open Space:

Where units front or side onto public open space, clear transitions between public open space and private yards should occur. Use of low walls, hedges, steps, decorative front yard fences or grade change are encouraged.

Builders are required to coordinate front access location with the Master Developer and receive approval from the ARC when designing front access walks along public open spaces.

Alley Design:

Creating alleys with visual interest and articulation will help ensure that they are assets to the community. Solutions include:

- Architecture Setback
- Architecture & Garage Massing
- Fences and Fence Location
- Landscape Zones
- Paving Materials



FRONT LOAD LOT REQUIREMENTS

Streetscape:

The design intent of the street environment is to encourage residents to “live to the street.” By requiring larger porches, minimizing front setbacks, and stepping the houses down to street level, the houses engage the street directly.

Building Orientation:

To engage the street scene, building orientation is required to address the primary street. In the case of corner lots, the primary street is that with which the adjacent, similarly-oriented lot addresses. Garage doors may be oriented toward the primary street or to either side. In corner conditions, garage doors may be oriented toward the primary street or to the side away from the secondary street.

Paving:

All entry walks and driveways shall be composed of concrete, (brick, or stone material(s) consistent with the adjoining architecture are subject to approval by the ARC). Driveway paving shall be consistent with front walk, broom finish with saw cut joints, (see landscape design criteria for pavement finish requirements). Front walks are not required on side-load garage conditions.

Utility/Equipment:

In the case that utility meters, A/C compressors, and any other mechanical equipment cannot be located and/or screened by architecture, landscape elements and fences shall be employed to screen such implements from public view and to minimize visual impact.

Refuse/Storage:

No trash, recycling, compost, wood piles, etc. shall be stored in publicly visible location. Appropriate enclosures, fencing, walls, or landscape screen will be employed to minimize visual impact.

Driveway Tapering:

1. If 20-24'11 from Face of Garage Door (FOG) to Back of Curb (BOC) or Edge of Alley (EOA) then taper to $\leq 23'$ at connection point
2. If $\geq 25'$ from Face of Garage Door (FOG) to Back of Curb (BOC) or Edge of Alley (EOA) then taper to $\leq 20'$ at connection point

Front Load 50' x 125' Lots

Front

- 10' Porch Setback
- 20' Building Setback

Rear

- 10' Building Setback

Standard Side

- 5'

Corner Side

- 10' Building Setback
- 20' Garage Setback

Minimum Porch Dimensions

- 6' Depth
- 6' Width

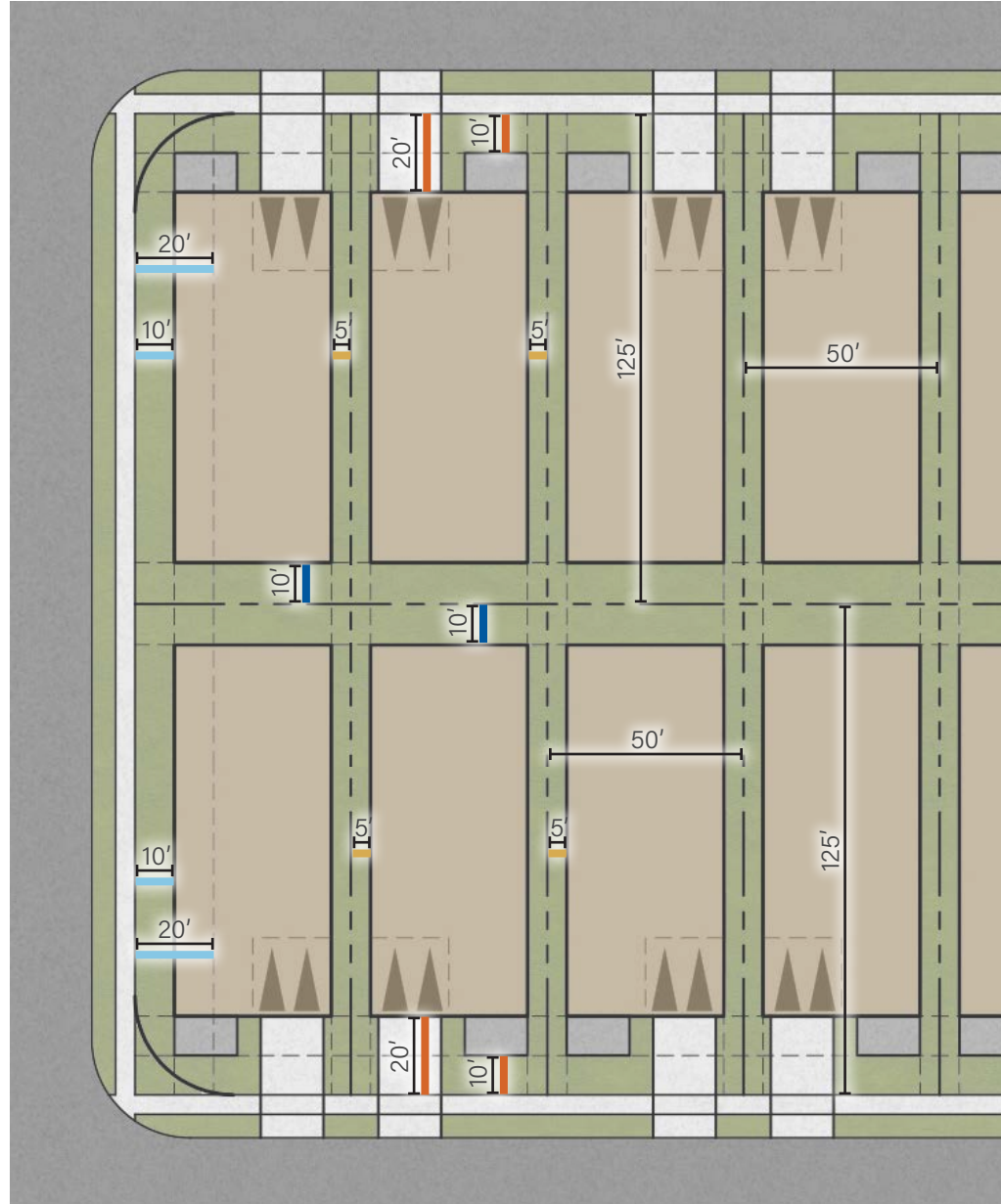

REAR LOAD LOT REQUIREMENTS

Streetscape:

The design intent of the street environment is to encourage residents to “live to the street.” By requiring larger porches, minimizing front setbacks, and stepping the houses down to street level, the houses engage the street directly.

Building Orientation:

To engage the street scene, building orientation is required to address the primary street it is associated with. In the case of corner lots, the primary street is that with which the adjacent, similarly-oriented lot addresses. If there is an alley to the rear of the lot, all garage access must come from the alley. No alley-loaded lots will be allowed to have access drives directly from the street (except in the case of double-fronted lots).

Paving:

All entry walks and driveways shall be composed of concrete, (brick, or stone material(s) consistent with the adjoining architecture are subject to approval by the ARC). Driveway paving shall be consistent with front walk, broom finish with saw cut joints, (see landscape design criteria for pavement finish requirements).

Utility/Equipment:

In the case that utility meters, A/C compressors, and any other mechanical equipment cannot be located and/or screened by architecture, landscape elements and fences shall be employed to screen such implements from public view and to minimize visual impact.

Refuse/Storage:

No trash, recycling, compost, wood piles, etc. shall be stored in publicly visible location. Appropriate enclosures, fencing, walls, or landscape screen will be employed to minimize visual impact.

Driveway Tapering:

1. If $\leq 20'$ from Face of Garage Door (FOG) to Back of Curb (BOC) then no taper required at connection point
2. If 20-24'11 from Face of Garage Door (FOG) to Back of Curb (BOC) then taper to $\geq 23'$ at connection point
3. If $\geq 25'$ from Face of Garage Door (FOG) to Back of Curb (BOC) then taper to $\leq 20'$ at connection point

Rear Load 50' x 125' Lots

Front

- 5' Porch Setback
- 10' Building Setback

Rear

- <5' Building Setback
- >15' Building Setback

Standard Side

- 5'

Corner Side

- 10' Building Setback
- 20' Garage Setback

Minimum Porch Dimensions

- 6' Depth
- 6' Width

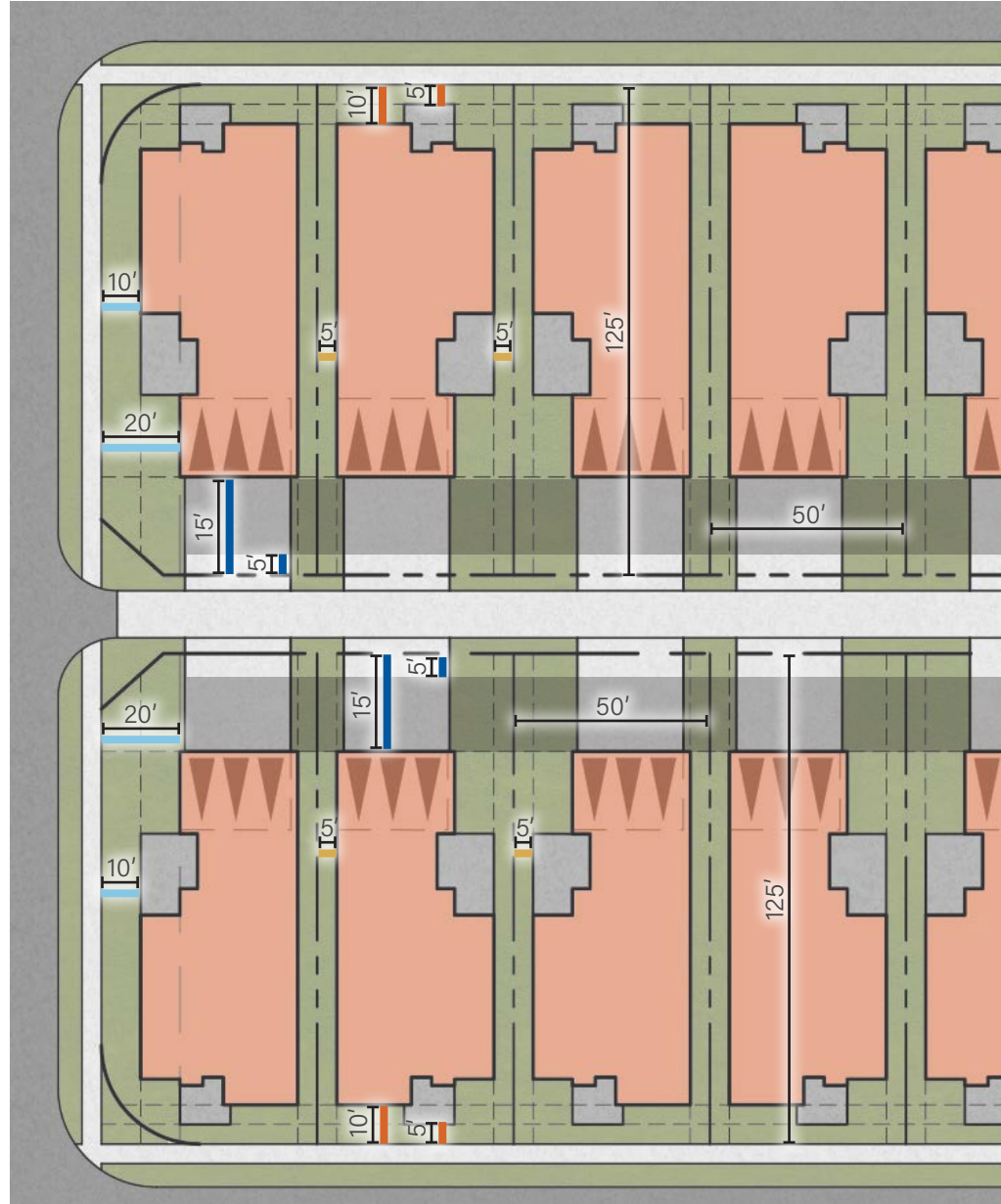

Rear Load 42' x 120' Lots

Front

- 5' Porch Setback
- 10' Building Setback

Rear

- <5' Building Setback
- >15' Building Setback

Standard Side

- 5'

Corner Side

- 10' Building Setback
- 20' Garage Setback

Minimum Porch Dimensions

- 6' Depth
- 6' Width



Rear Load 35' x 93' Lots

Front

- 5' Porch Setback
- 10' Building Setback

Rear

- <5' Building Setback
- >15' Building Setback

Standard Side

- 10' Active Side
- 0' Passive Side
- 5' Both Sides*

Corner Side

- 10' Building Setback
- 20' Garage Setback

Minimum Porch Dimensions

- 6' Depth
- 6' Width

***Note:** Garages are required to be on far end of alley entrance and street entrance. Due to this condition one lot in the center of the block will require the building to be mirrored. In that condition the building must be centered in the lot with 5' side setback on each side.

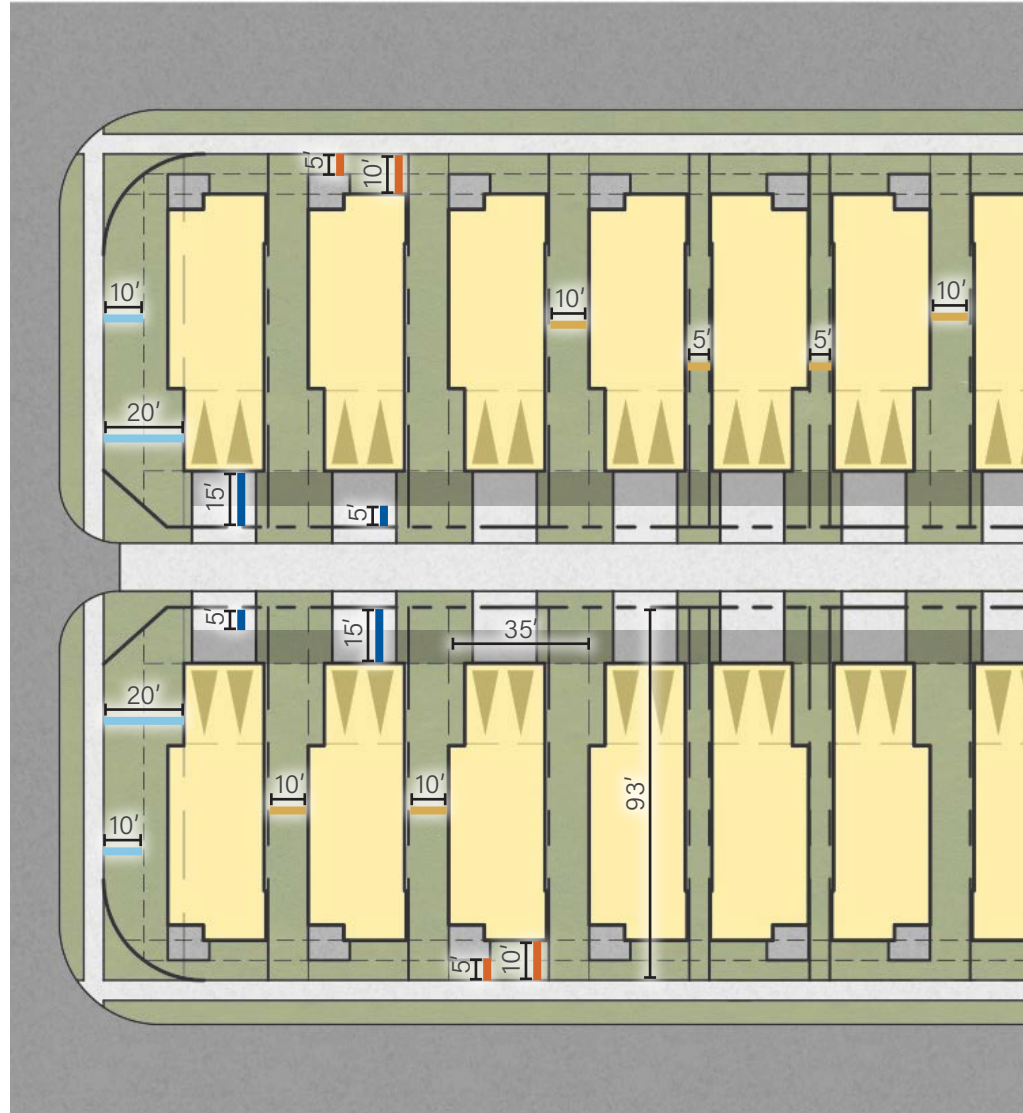

STREET SECTION 60' R.O.W.

60' ROW at Wide Front Open Space

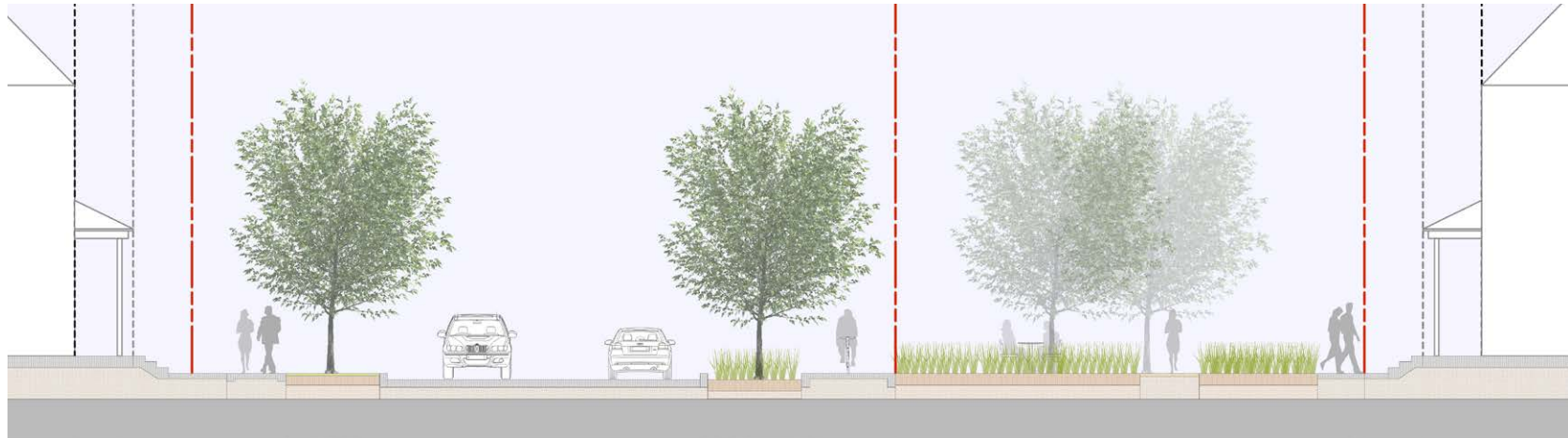

60' ROW at Wide Front Open Space with Parallel Parking



60' ROW at Narrow Front Open Space

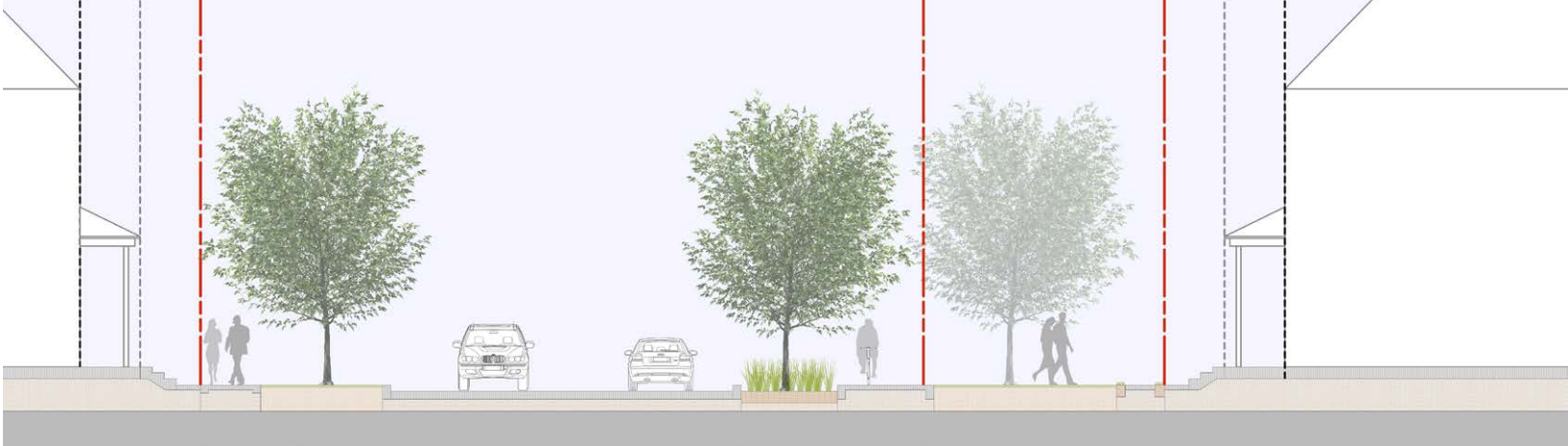

STREET SECTION 50' R.O.W.

50' ROW at Narrow Front Open Space



50' ROW at Front Loaded Lots Along Lake



Alley at Planting and Fence

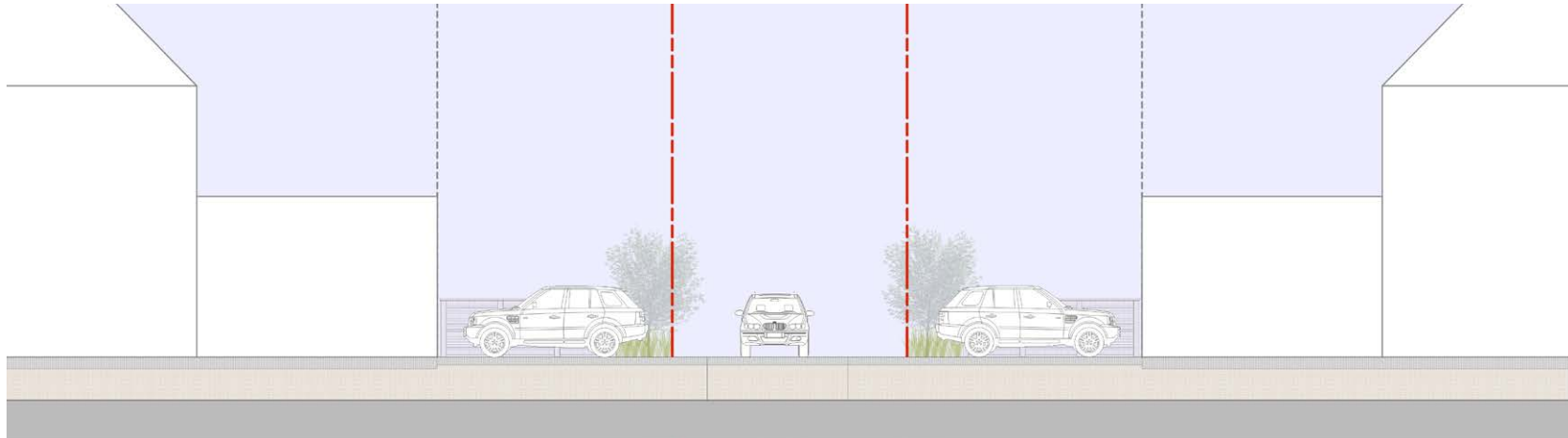

Alley at Driveway

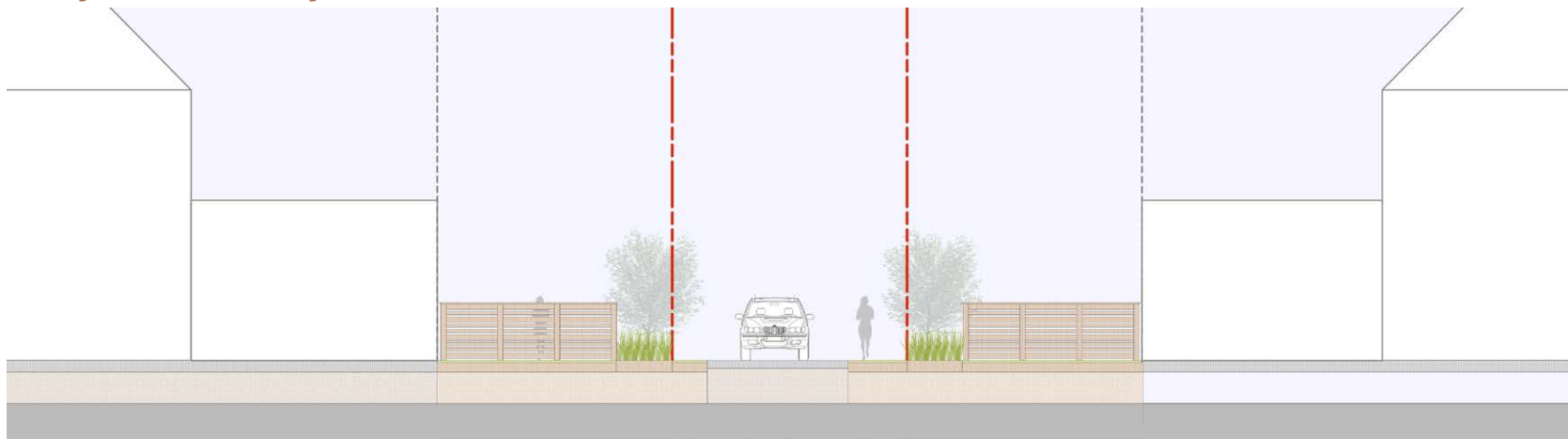





LANDSCAPE DESIGN CRITERIA

BRIDGELAND AND CENTRAL EMERALD HEIGHTS

LANDSCAPE CHARACTER

Overall Design Intent

Emerald Heights is part of the overall Bridgeland open space network. The neighborhood of Emerald Heights is anchored by a centralized park with a variety of active and passive elements. This park is further connected to the Bridgeland open space network through a series of trails and linear parks. Emerald Heights offers new and contemporary designs and practices to reinforce the identity of Bridgeland as a premiere development.

Individual landscapes within Emerald Heights are expected to support the overall open space concept. This can be accomplished through several avenues such as plant selection, material selection, planting bed location and design, integration between public and private landscapes, etc. In the following section of the Design Guidelines for Emerald Heights, strategies and requirements are discussed to enumerate the intended landscape approach. Adherence to these Guidelines is the first step toward creating a cohesive landscape character throughout Emerald Heights.

The purpose of these landscape guidelines is to support builders, homeowners, architects and their respective agents and representatives in producing landscapes that achieve the desired results while allowing flexibility and creativity. Any variances from these guidelines shall be a subject to approval by the ARC.



EMERALD HEIGHTS SITE PLAN

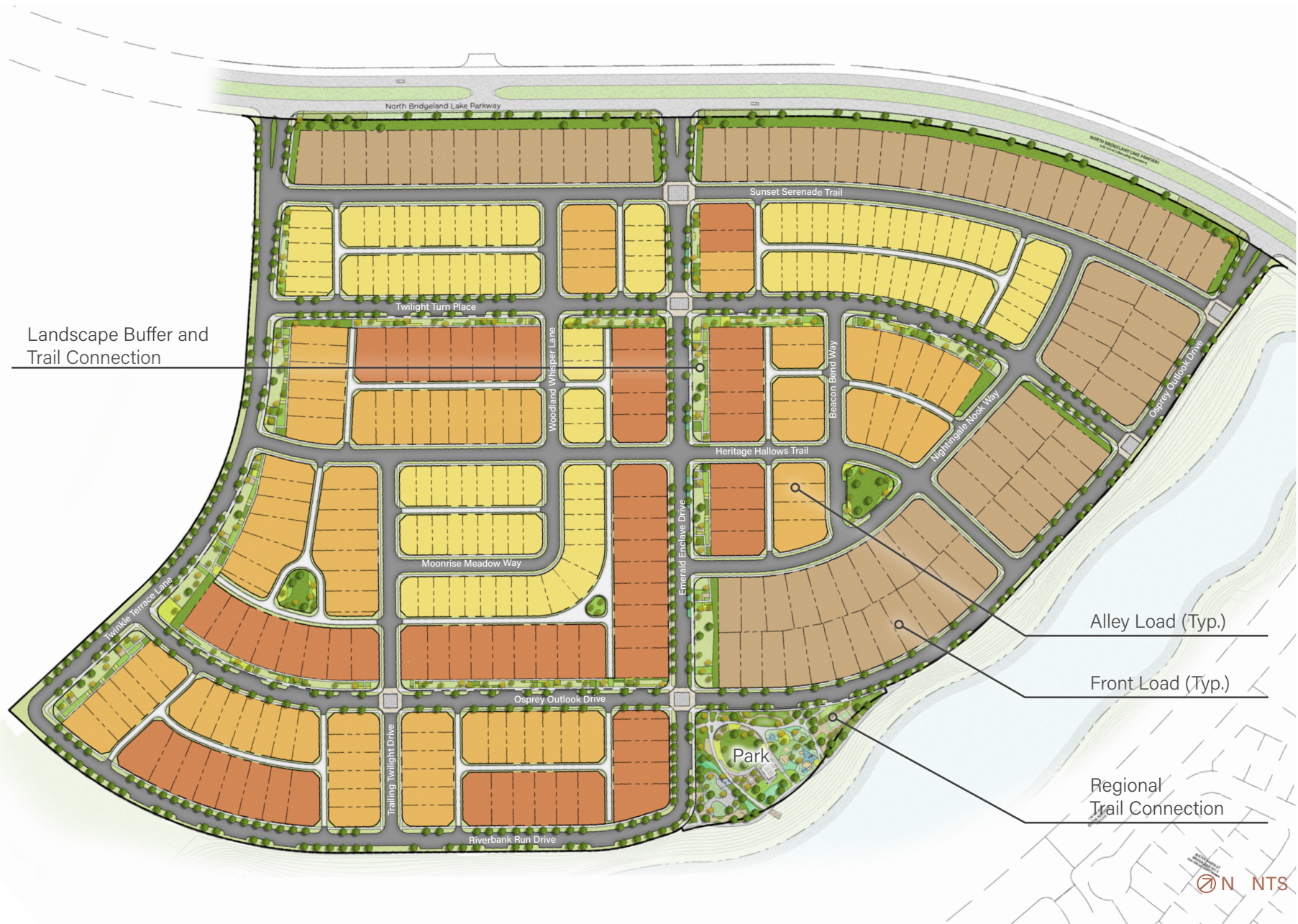

Landscape Buffer and Trail Connection

Alley Load (Typ.)

Front Load (Typ.)

Regional Trail Connection

LANDSCAPE IMAGE

Character

To produce a cohesive community identity, it is important to coordinate landscape elements. The character of Emerald Heights incorporates several tenets of contemporary landscape design, along with strategies that have proven to be timeless. Emerald Heights will employ formal design elements along with contemporary interpretations of formal elements to create a cohesive community identity.

Plant Selection

While there are several plants to choose from, the successful landscape design will be discerning in its plant selection. A limited variety of plants, selected for seasonal interest and textural contrast is ideal for creating a cohesive aesthetic throughout the community.

Massing

Along with plant selection, massing of the same plants with contrasting accents is essential to obtaining the desired aesthetic. While it is not required to match plant species between lots and public areas, simulating similar massing and organizational patterns will foster a cohesive community character.

Grading

Grading design for Emerald Heights should feel natural and flowing. Rigid, highly engineered topography shall be discouraged. When using berms, undulate the ridgeline to create visual interest and avoid straight barriers. If employing site retaining walls, grade changes shall be less than 30 inches from top of wall to base of wall. Where possible, builders should opt for naturalized grading solutions instead of site walls. Aesthetic grading strategies shall comply with all applicable building codes.



Choose a limited variety of plants that create dynamic contrast. Use high-impact plantings to create visual interest and subtle background plants to highlight architectural and site elements



Formal groupings of plants create a sense of order while contrasting textures and colors create visual interest



Simple background colors should be used to highlight the unique form and color of accent plant materials.

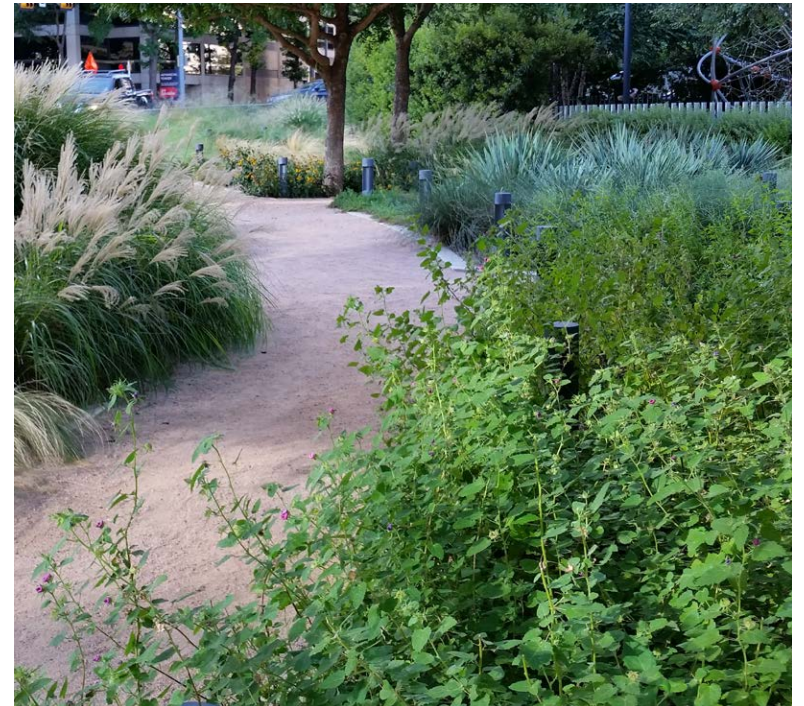
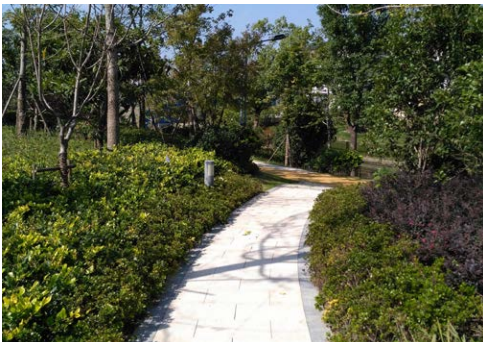

INTEGRATION + TRANSITION

Transitions Between Lots

It is important to integrate styles and character within the front yard of adjacent lots to create a cohesive community identity. Integrating individual landscapes between lots creates a different yet compatible landscape expression.

Provide a cohesive and flowing relationship with front yard landscaping between adjacent lots and public open space. Use the following techniques to visually unify the streetscape by blending adjacent front yard landscapes:

- Blend together tree and shrub masses between lots
- Design front yard turf areas that connect to each other
- Minimize formal plantings and hard edges
- Create a single, unified planting bed or mulch area with a consistent edge-line between adjacent lots

Integrating Private Landscapes with Public Landscapes

The overall community network of open space and parks defines the public landscapes within Emerald Heights. The individual landscapes corresponding with residential lots create a context within which the public landscape exists. While the aesthetic qualities of the two types of landscapes may be different, it is important that they are compatible and create an overall identity. By focusing on how edges are treated, coordinating plant selection, and respecting the design style of adjacent landscapes, the Emerald Heights landscape concept will be expressed throughout the community.

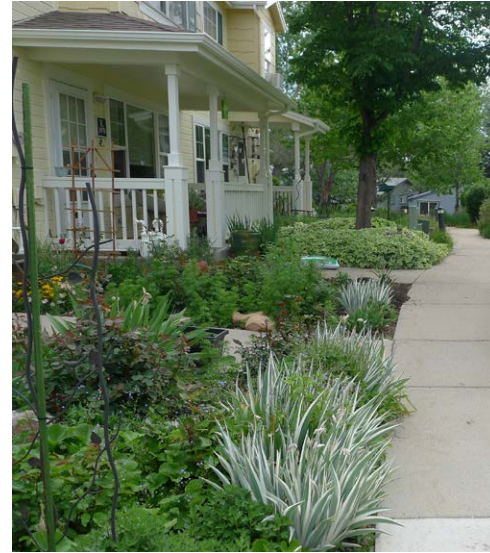

Planting strategies on adjacent lots should create a "continuous" landscape.

Allow planting beds and massings to "jump" property lines and walks to create a cohesive community aesthetic



When addressing a common open space, use similar plant material and planting strategies



LANDSCAPE REQUIREMENTS FRONT LOAD

Front Yards

Front yards shall incorporate a least 1 shade tree. Trees cannot be planted within 20' of street trees. If street trees preclude available space for a shade tree, the builder-provided shade tree may be excluded with approval from the ARC. Shrub beds and other landscape improvements are preferred over turf/sod. Shrub beds shall incorporate larger shrubs closer to the building, gradually stepping down as the landscape approaches the street.

Interior Side + Rear Yards

Interior side and rear yard landscapes shall be consistent with and complement the overall landscape concept for the lot, while providing harmonious relationships with adjacent lots.

Enhanced Conditions

For lots identified in the Site Plan + Lot Criteria Section of these design guidelines as "enhanced," additional landscape requirements shall be required. Enhanced condition lots should be heavily planted to increase privacy and aesthetic value.

Planting Details

Shrub beds may include any of the following: Shrubs, Screening Plantings, Perennials, Ornamental Grasses, Vines, and Ground Covers. The planting shall be responsive to the architecture (provide a "grounding" effect) and incorporate a reasonable variety of types and species of plants.

Rear + Interior Side Yard

Interior side yard and rear yard landscaping should be planted and maintained to provide shade and usable space. Landscape character should be consistent throughout the lot. Additionally, sustainable practices are encouraged in the rear and interior side yards. These practices may include but are not limited to: fruit trees, vegetable gardens, mosquito repellent plants, native plants, minimized lawn area, rain water collection for irrigation, rain gardens, and composting.

Notes:

1. Reference Landscape Requirements and Approved Planting List
2. Full coverage irrigation required in all planting areas.
3. Sod shall be Tifway 419 or Celebration Bermuda
4. Shrub bed coverage to require 2"-3" of hardwood mulch
5. Planting shall not impede drainage
6. Shrub bed coverage to consist of min. 50% evergreen planting, 20% ornamental grass planting, & 30% additional planting
7. Tree requirements may be waived by the ARC upon conflicting location of street trees.

Front Yard

- Shade Trees (1 minimum)*
- Ornamental Trees (2 minimum)
- Shrubs Beds (50 % min. coverage)
- Turf (50% maximum coverage)

Rear Yard

- Shade Trees (1 minimum)
- Shrubs Beds (0 % min. coverage)
- Turf (100% maximum coverage)

Enhanced Conditions

The following requirements are applied in addition to the above requirements. Each occurrence of an enhanced condition compounds upon existing requirements. If space or off-lot plantings create conflicts, requirements may be met within the fence.

Corner-Side + Open Space Lots

- Ornamental Trees (2 minimum)
- Shrubs Beds (15% min. coverage)
- 3' Wide Shrub Bed required between sidewalk and the yard fence on Corner Side Lots that terminate at the ROW.

Visual Terminus

- Ornamental Trees (+1 minimum)
- Shrubs Beds (+15% min. coverage)

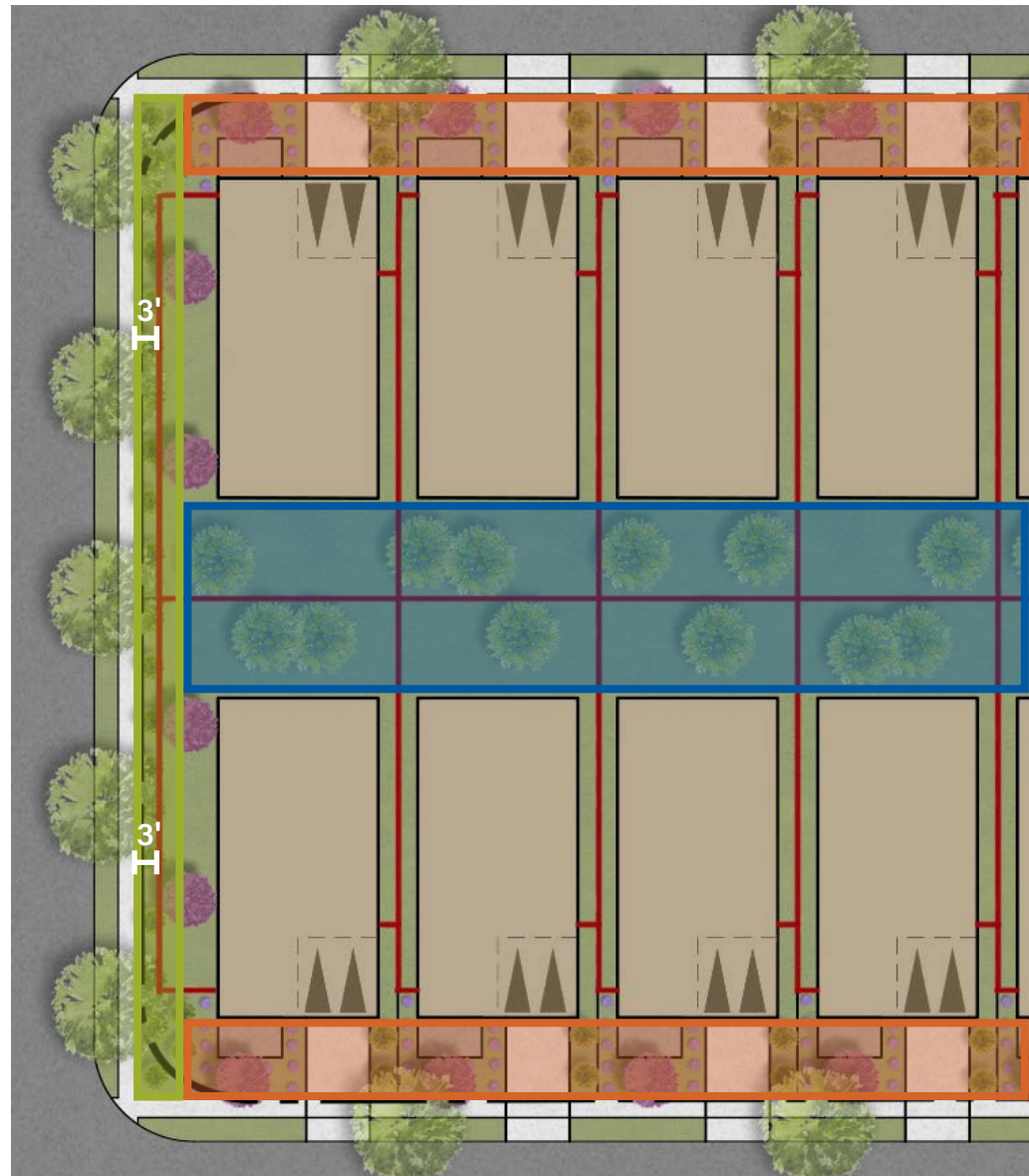

*Exceptions to requirements may be granted by ARC

**As space allows. If there are conflicts with street trees, the street trees take priority and additional tree requirement may be waived

LANDSCAPE REQUIREMENTS REAR LOAD

Front Yards

Front yards shall incorporate a least 1 shade tree. Trees cannot be planted within 20' of street trees. If street trees preclude available space for a shade tree, the builder-provided shade tree may be excluded with approval from the ARC. Shrub beds and other landscape improvements are preferred over turf/sod. Shrub beds shall incorporate larger shrubs closer to the building, gradually stepping down as the landscape approaches the street.

Alley Scape

Landscape areas between the rear fence line and the alley R.O.W. shall be treated in a fashion to accentuate aesthetic needs as well as facilitating safety and ease of use.

Enhanced Conditions

For lots identified in the Site Plan + Lot Criteria Section of these design guidelines as "enhanced," additional landscape requirements shall be required. Enhanced condition lots should be heavily planted to increase privacy and aesthetic value.

Planting Details

Shrub beds may include any of the following: Shrubs, Screening Plantings, Perennials, Ornamental Grasses, Vines, and Ground Covers. The planting shall be responsive to the architecture (provide a "grounding" effect) and incorporate a reasonable variety of types and species of plants.

Rear + Interior Side Yard

Interior side yard and rear yard landscaping should be planted and maintained to provide shade and usable space. Landscape character should be consistent throughout the lot, however, specific quantities, sizes and types shall be at the owner's discretion. Additionally, sustainable practices are encouraged in the rear and interior side yards. These practices may include but are not limited to: fruit trees, vegetable gardens, mosquito repellent plants, native plants, minimized lawn area, rain water collection for irrigation, rain gardens, and composting.

Notes:

1. Reference Landscape Requirements and Approved Planting List
2. Full coverage irrigation required in all planting areas.
3. Shrub bed coverage to require 2"-3" of hardwood mulch
4. Planting shall not impede drainage
5. Shrub bed coverage to consist of min. 50% evergreen planting, 20% ornamental grass planting, & 30% additional planting
6. Tree requirements may be waived by the ARC upon conflicting location of street trees.
7. Step Pavers are prohibited in the tree lawn between the road and the sidewalk.

Front Yard

- Ornamental Trees (1 minimum)
- Shrubs Beds (50 % min. coverage)
- Turf (50% maximum coverage)

Alley Scape

- Ornamental Trees (1 minimum)
- Shrubs Beds (50 % min. coverage)
- Turf (50% maximum coverage)

Enhanced Conditions

The following requirements are applied in addition to the above requirements. Each occurrence of an enhanced condition compounds upon existing requirements. If space or off-lot plantings create conflicts, requirements may be met within the fence.

Corner-Side + Open Space Lots*

- Ornamental Trees (2 minimum)
- Shrubs Beds (15% min. coverage)
- Shrubs Beds at Alley Entrance (50% min. coverage)
- 3' Wide Shrub Bed required between sidewalk and the yard fence on Corner Side Lots that terminate at the ROW.

Visual Terminus*

- Ornamental Trees (+1 minimum)
- Shrubs Beds (+15% min. coverage)

Double-Front (rear landscape)*

- Ornamental Trees (+1 minimum)
- Shrubs Beds (+15% min. coverage)

Alley Terminus*

- Shrubs Beds (+25% min. coverage)

— Fence
- - - ROW



*Exceptions to requirements may be granted by ARC

**As space allows. If there are conflicts with street trees, the street trees take priority and additional tree requirement may be waived

LANDSCAPE REQUIREMENTS LOT RESPONSIBILITY

 Plat Boundary

 Lot Up-Charge

Lot up-charge for lots fronting open space reserves.

 Street Trees



Street trees (in addition to grass, irrigation and sidewalk) in front loaded lots along Osprey Out-look Drive are to be installed by Home Builder at 10' away from property line opposite of garage locations to align with trees along lake. Refer to fencing diagram for garage locations. Trees shall meet *Quercus virginiana* (Live Oak), 100 gallon, single trunk, full canopy all the way around. All trees shall be from the same nursery.

 Developer Responsible

The Developer is responsible for tree placement in designated open space and park areas.



Lots indicated with star (*) and landscape highlighted in blue indicate Developer installed landscape enhancements within R.O.W. and reserve including sidewalks, street trees, grass, plantings, and irrigation.

HOA maintains landscape (street trees, grass) and irrigation from edge of sidewalk to edge of curb (sidewalk is excluded) on these designated lots (*).



Builder Responsible

The Builder is responsible for sidewalk construction in front of homes, except for areas indicated as "Developer Responsible". That includes areas that extend in to the Right-of-Way.

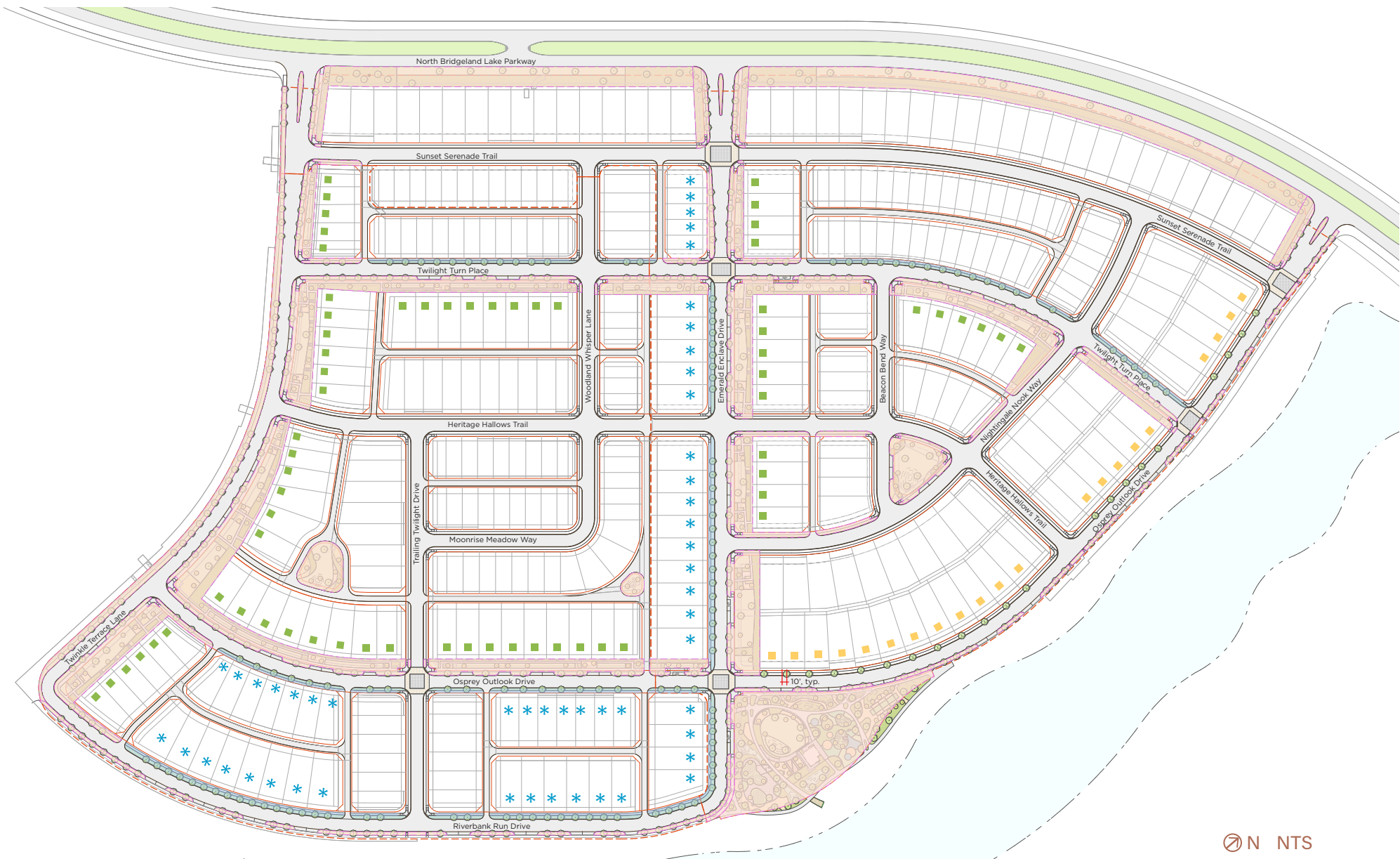

FENCING + GATES

Fencing

Enhanced Fence Requirements

- Enhanced Fence Requirements:
- Height: 5'
- Horizontal Slat Pattern (See Exhibit):
- 6" Slat-2" Space-4" Slat-2" Space-4" Slat
- Ground Clearance: 2"-4"
- Fence/Post Cap: 1" Lateral Slat (1" overhang)
- Post Spacing: 6'-0" O.C.

Standard Fence Requirements

- Height: 5'
- Horizontal Slat Pattern (See Exhibit):
- 6" Slat-1" Space-4" Slat-1" Space-4" Slat
- Ground Clearance: 2"-4"
- Fence/Post Cap: 1" Lateral Slat (1" overhang)
- Post Spacing: 6'-0" O.C.

Alley Fencing Requirements

- Fences must be offset (setback) a minimum of 2' from the garage face
- No fence shall be allowed within 5' from alley R.O.W. or access easement to provide landscape screening
- For lots less than 40' wide, all fences shall be recessed 2' from the garage facade
- Fences at alley entrances shall extend 10' beyond the garage facade.

DATE

January 14, 2026

- Preliminary Plat
- Final Plat
- Recorded Plat

LEGEND

- 5' High Standard Wood Fencing by Builder
- 5' High Enhanced Wood Fencing by Builder
- ← Specified Driveway Location
- 5' Wide Sidewalk by Builder
- Ⓡ Required Enhanced Side Architecture
- Ⓟ Preferred to meet Enhance Side Architecture
- R.O.W/Private Alley/Property Line

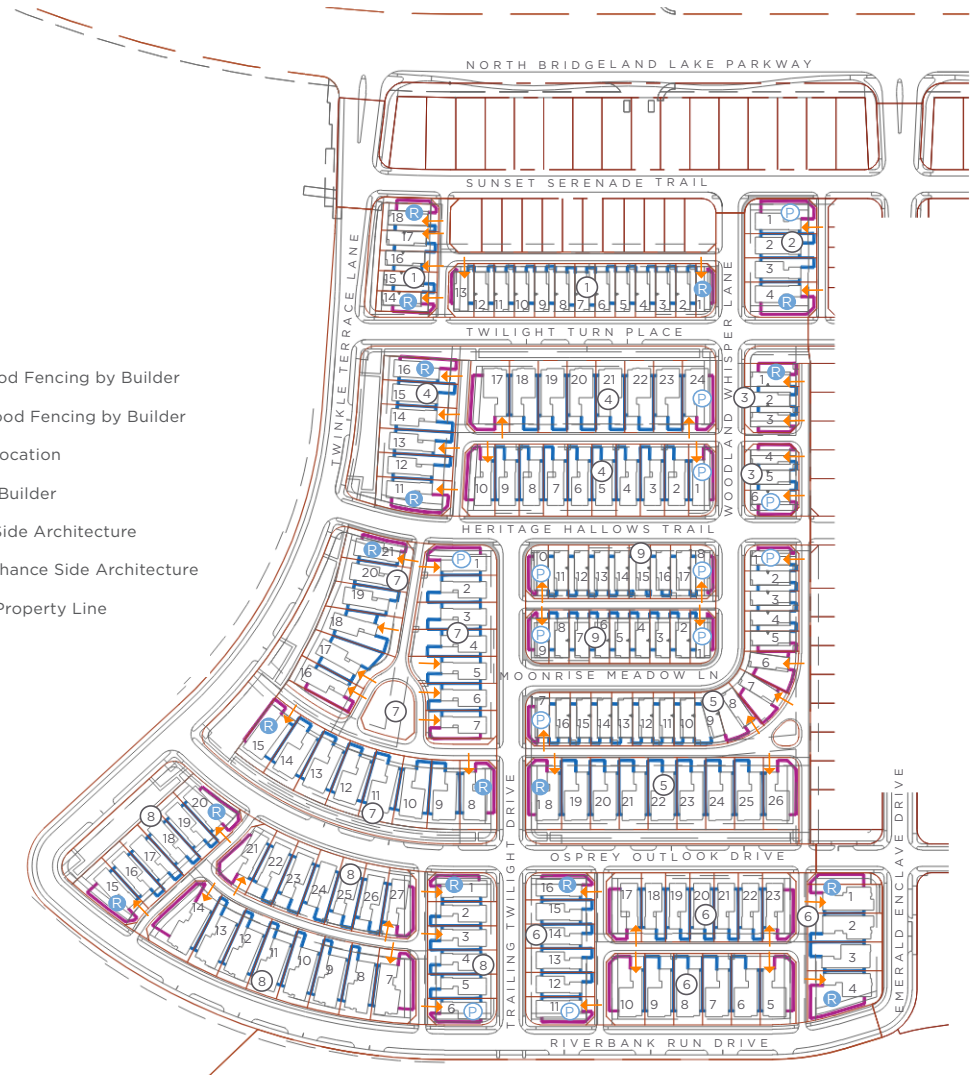

NOTES

- Refer to Emerald Heights Design Guideline for additional information.
- Any driveway that crosses sidewalk shall have a maximum cross slope of 2%

FENCING + GATES

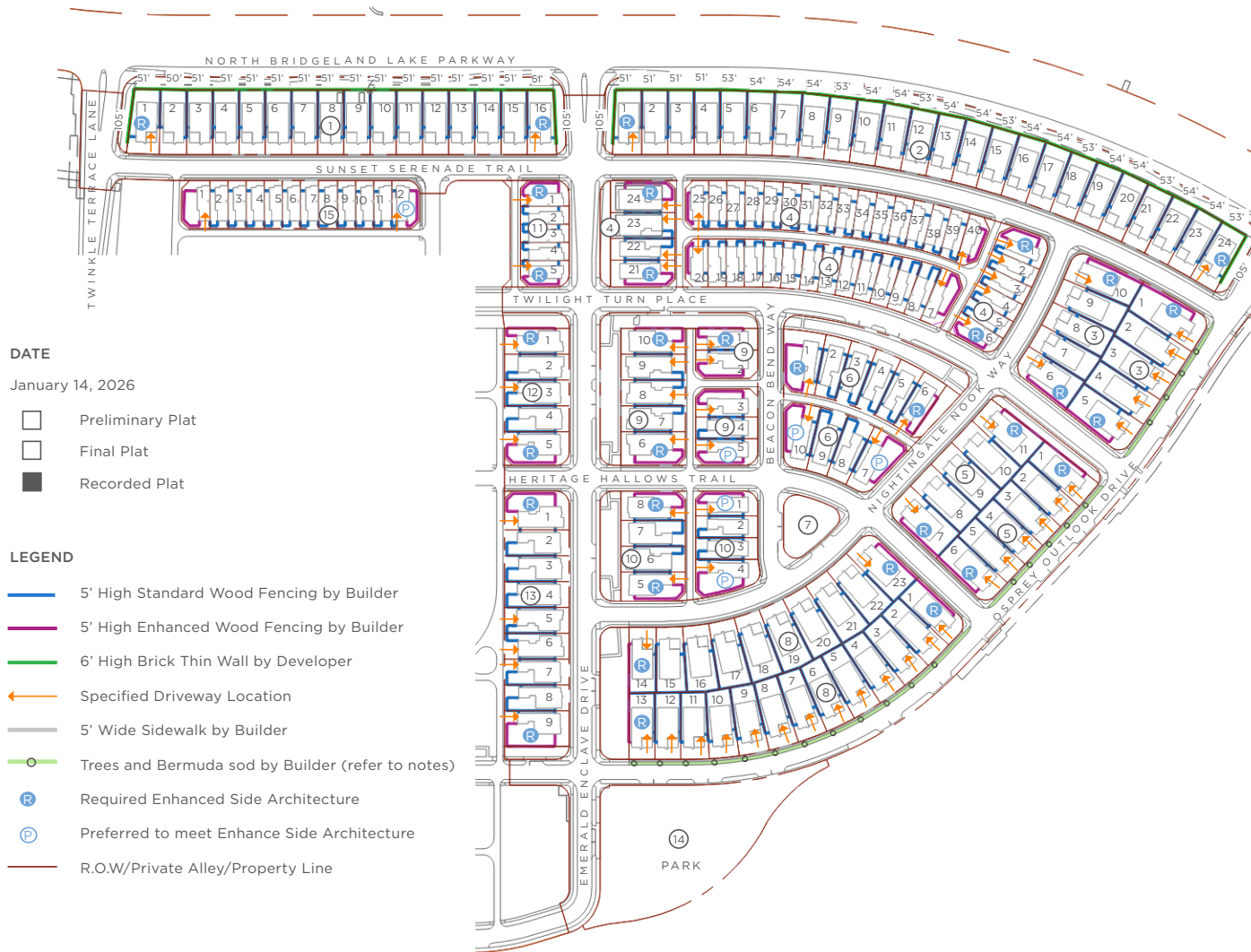

DATE

January 14, 2026

- Preliminary Plat
- Final Plat
- Recorded Plat

LEGEND

- 5' High Standard Wood Fencing by Builder
- 5' High Enhanced Wood Fencing by Builder
- 6' High Brick Thin Wall by Developer
- ← Specified Driveway Location
- 5' Wide Sidewalk by Builder
- Trees and Bermuda sod by Builder (refer to notes)
- R Required Enhanced Side Architecture
- P Preferred to meet Enhance Side Architecture
- R.O.W/Private Alley/Property Line

NOTES

- Refer to Emerald Heights Design Guideline for additional information.
- Any driveway that crosses sidewalk shall have a maximum cross slope of 2%
- Trees by builder shall be 65 gallon, Cathedral Live Oak (*Quercus virginiana* 'Cathedral'). Located 10' from property line, on the side shown.

Gates

Design Intent

All gates in Emerald Heights shall follow these guidelines regardless of enhanced or standard character. The gate design is intended to be subtle yet noticeable.

Gate Requirements

(See Exhibits on previous spread for detailed call-outs)

Slat Pattern (See Exhibit):

- 6" Slat-1" Space-4" Slat-1" Space-4" Slat
- Ground Clearance: 2"-4" (2" minimum)
- Gate Cap: 1"x4" Wood Cap
- Gate Opening: 4'-0"
- Gate Width: 3'-9"
- Hardware: (2) T-Hinges; (1) Latch
-

Gate Location

Gates, as access to the rear yard, are essential for maintenance and livability; however, placement of gates shall be restricted in the following conditions:

- No gates shall be located on the secondary street in a corner condition
- Gates shall not allow access between lots
- Gates shall not straddle property lines
- If access may be accommodated through the garage, gates may be excluded
- Additional gates may be used to provide access to utilities in alley conditions with approval from the ARC

FUNDAMENTAL + WATER CONSERVATION

Landscape installation and long-term maintenance depend on appropriate planning before anything goes in the ground. Some principles for accomplishing a successful landscape include:

- Design and install landscaping in a timely fashion
- Locate plants to prevent water damage, prevent soils exposure, and stabilize slope banks
- Conserve water and provide coordinated landscape irrigation systems geared towards the needs of different plant species
- Harmonize mulch type, size, and color between individual lots

Plant Location

Cluster trees adjacent to the home as opposed to straddling the property line

Use the following methods to prevent water into the home's foundations:

- Design and locate roof drain gutters to convey storm water away from building foundations and associated foundation plantings
- Grade the ground around the home to slope away from the foundation

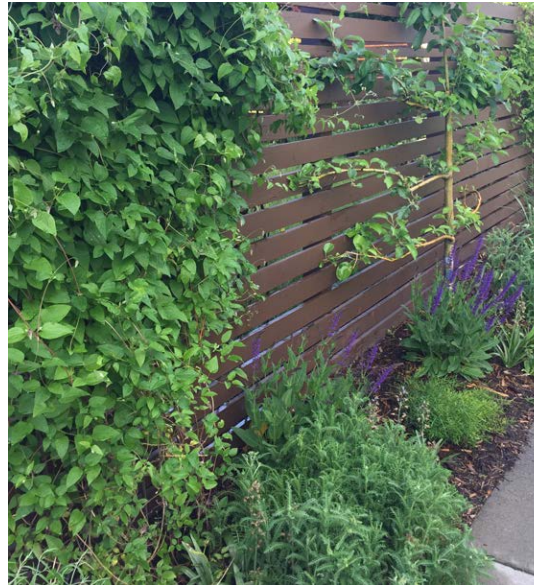

Utilize the landscape strip between the sidewalk and the fence to plant shrubs and perennials. Landscape materials should be vining or more vertical so as not to infringe on the walk. Refer to the plant materials list at the end of this chapter for preferred plant selections (additional plants may be approved by the ARC).

Planting Beds

- Planting bed "islands" (surrounded by turf) are discouraged.
- Planting Beds shall not be rectangular in shape unless bounded by architecture or paving on all sides.
- Plant shrubs, ground-covers, and flower beds to cover fifty percent of the shrub or flower bed within three years
- Mulch planting beds to discourage weed growth with wood mulch
- Use wood mulch to mulch perennial and annual flowerbeds covering any bare ground

Irrigation

Design irrigation systems with 100% coverage on beds and turf to minimize over-spray and water-waste. Limit overhead spray irrigation to turf/sod grasses and flowering ground cover areas. All other areas shall use drip irrigation. Maximize irrigation areas. The recommended minimum width of spray areas shall be six feet. Use low angle spray nozzles (45 degrees) adjacent to paved areas. Irrigation is required on all landscaped areas (excluding black star gravel in side yards).

Turf + Sod

Turf/grass sod shall be required on all private property instead of seeding, which can promote weed growth and inconsistent coverage

Edging Materials

Shrub bed edges may be spaded or may use aluminum or stone edging materials. No other edging materials are permitted.

FUNDAMENTAL + WATER CONSERVATION

Mulch

All planted areas shall be mulched with a brown hardwood, mulch 2"-3" deep. Add mulch to planting beds as necessary to maintain a mulch layer throughout the year

Water Conservation

Encourage landscapes that are designed to conserve water, harmonizing with the regional and individual lot micro-climate conditions. Group plants based on water needs. Use plants, drip irrigation systems, and maintenance practices that conserve water.



Landscape Walls

For elevated shrub beds, landscape walls may be permitted by the ARC. Landscape wall material must match or relate to the architecture (dry-stacked stone walls and other loose materials are not permitted). Landscape walls should be no more than 24" in height (greater heights may be approved by the ARC).

Soil

Due to the impact of construction on soil quality and structure, soil amendments with organic fertilizers and quality compost shall be required. These measures ensure healthy soils, reduce water requirements, reduce fertilization needs, and support healthier plant life.

Conservation

In addition to water conservation, efforts shall be made throughout development to utilize locally sourced materials and renewable resources.

Utilities

Lots that have access from alley ways also access many of their utilities from alleys and access easements. Due to this condition, utilities and utility meters shall be located prior to any landscape improvements including fencing. If utility boxes occur on an owner's property and are not otherwise screened, the homeowner shall screen boxes with 3' height minimum shrubs.

Decorative Pots

Decorative pots are allowed; however, pots shall be style appropriate, of a quality material, and limited as to not appear cluttered. Review of decorative pots is at the discretion of the ARC.

SITE IMPROVEMENTS

Integrating Porches with Street Grade

The difference in finished lot grade and finished street grade requires architects and builders to be cognizant of how the architecture, specifically of porches and covered entries, integrates with the grade change. When steps are required, they must begin at the edge of the patio and terminate no less than 4' from the edge of sidewalk.

To the side are some recommended strategies for creating successful entry sequences. All solutions may be subject to DRC review.



Incorporate low walls and planters to integrate steps into grade without exposing stair ends.



Avoid conditions in which the porch and stairs are exposed above grade by more than 12".



In conditions with extreme grade change, use landscape walls to break up grade change and provide planting areas.



When multiple steps are required, break steps into several sets to mimic adjacent grades.



Integrate steps and site walls to create interesting site elements. Return steps to a site wall where possible.

SITE IMPROVEMENTS



Lighting

Lighting for safety and aesthetics may be allowable in Emerald Heights.

Standards:

Outdoor lighting may be installed according to the following requirements:

- **Front lots:** All porches shall have at least one recessed down-light or sconce over the porch and shall be mounted under the soffit. Bare bulbs, except for Edison bulbs, are not allowed on exterior applications visible from the street, public sidewalks, alleys, or adjacent properties. Floodlighting is not allowed.
- **Alleyways:** all garages shall have at least one recessed down-light or sconce on each side of the garage door (floodlights are not allowed).
- **Private landscape areas:** additional outdoor lighting in the form of recessed down-lights, wall sconces, and shielded wall-mounted lights are acceptable. Light shall be on a timed system that turns off by 12 pm. Flood lights are not allowed.
- **Up-lights** are allowable to highlight trees and architectural features providing that they are shielded to hide the source. Tree up-lights shall be limited to 20 watts per tree.

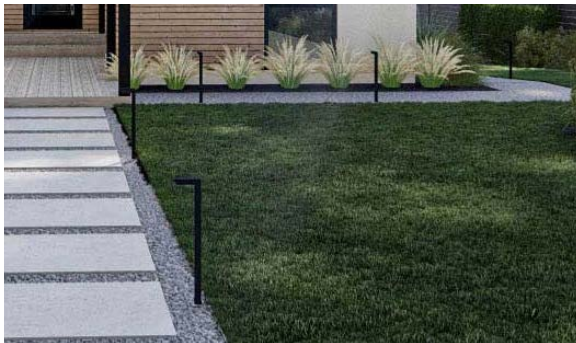

SITE IMPROVEMENTS

Overview

All site improvements shall be reflective of the contextual architectural styles and landscape elements. Features that may be seen by the public or from the primary street must be respectful of the aesthetic character of the associated house. Elements that may be considered eyesores shall be screened to appropriately hide them from public view. In the case that screening is not possible, such elements shall be subject to review by the ARC.

Reasonable effort shall be made to match materials and treatments of all site improvements to the architectural style of the house and to act as an extension of the architecture.

Integrating Private Landscapes with Public Landscapes

Front Walk Standards:

- Minimum width: 5'-0"
- Must meet public sidewalk at right angle
- Concrete shall have a broom finish (must be consistent throughout lot).

Utilities + Screening

Hedges, fences and low enclosures are required for the purpose of screening miscellaneous equipment, trash receptacles and other functional equipment that may be deemed an eyesore. Efforts shall be made to locate such equipment in areas not visible from adjacent streets or alleys. Screened areas must be at least 4" taller than elements to be screened, but not taller than fencing (where possible).

Other elements such as play structures, pool, pergolas, arbors and trampolines shall be subject to approval by the ARC.

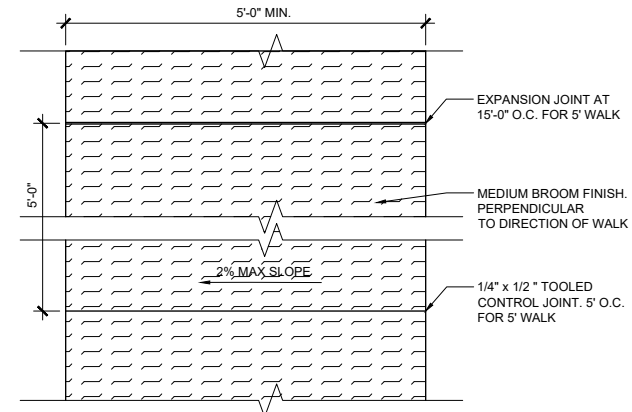

NOTES:

- 1) ALL CROSS SLOPES ON CONCRETE WALKS SHALL NOT EXCEED 2%.
- 2) ALL CONCRETE WORK SHALL BE IN COMPLIANCE WITH CURRENT ADA REGULATIONS.
- 3) ALL CROSS SLOPES SHALL PITCH TOWARD THE STREET.
- 4) ALL TIE-INS TO CURB SHALL UTILIZE DOWEL CONNECTION.
- 5) REFER TO PARKLAND VILLAGE DESIGN GUIDELINES FOR TECHNICAL DETAILS

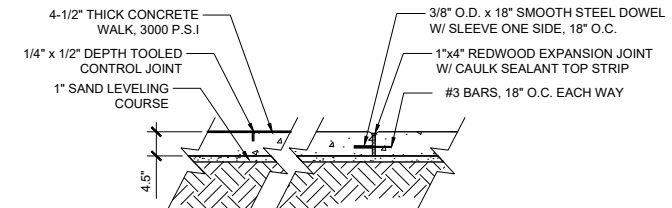

NOTES:

- 1) ALL CROSS SLOPES ON CONCRETE WALKS SHALL NOT EXCEED 2%.
- 2) ALL CONCRETE WORK SHALL BE IN COMPLIANCE WITH CURRENT ADA REGULATIONS.
- 3) ALL CROSS SLOPES SHALL PITCH TOWARD THE STREET.
- 4) ALL TIE-INS TO CURB SHALL UTILIZE DOWEL CONNECTION.
- 5) REFER TO PARKLAND VILLAGE DESIGN GUIDELINES FOR TECHNICAL DETAILS

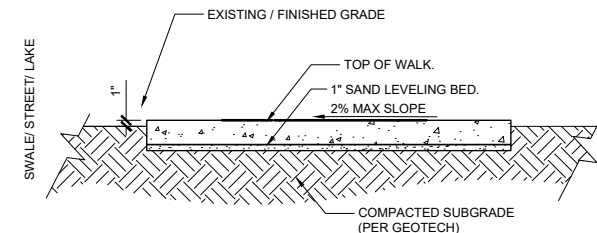

NOTES:

- 1) ALL CROSS SLOPES ON CONCRETE WALKS SHALL NOT EXCEED 2%.
- 2) ALL CONCRETE WORK SHALL BE IN COMPLIANCE WITH CURRENT ADA REGULATIONS.
- 3) ALL CROSS SLOPES SHALL PITCH TOWARD THE STREET.
- 4) ALL TIE-INS TO CURB SHALL UTILIZE DOWEL CONNECTION.
- 5) REFER TO PARKLAND VILLAGE DESIGN GUIDELINES FOR TECHNICAL DETAILS

SITE IMPROVEMENTS

Patios



Construct decks of similar materials and colors as that of the architecture



Cap garden walls with concrete coping, cut stone, or brick masonry



Integrate terraces and low garden patio walls with the house, composed of similar materials



Design decks and patios to be a natural extension of the house.

SITE IMPROVEMENTS

Design Intent

Emerald Heights has two fence styles: Standard/Interior fences and Enhanced Fences. These two styles only differ in the horizontal slat pattern. Overall, fences shall be five feet tall with horizontal wood slats and stained (Sikkens 058-Oxford Brown). The joints shall be constructed in such a way that neither neighbor will have exposed joints and hardware.

General Notes

1. All wood shall be rough sawn cedar. Stain shall be Sikkens 058-Oxford Brown and shall be approved by the ARC prior to use. All fencing within the community shall be stained the same color.
2. All gate hardware shall be black.
3. Provide minimum 2" clear (4" maximum) between bottom rail of fence and finish grade.
4. Post spacing shall be 6'-0" O.C.
5. Fasteners shall be galvanized screws/nails.



Design Requirements

Enhanced Fencing

The fencing that encompasses front facades and corner side lots has larger spacing between slats to give a more open appearance.

Enhanced Fence Requirements:

- Height: 5'
- Horizontal Slat Pattern (See Exhibit):
- 6" Slat-2" Space-4" Slat-2" Space-4" Slat
- Ground Clearance: 2"-4"
- Fence/Post Cap: 2" Lateral Slat (1" overhang)
- Post Spacing: 6'-0" O.C.

Standard Fencing

While similar to the corner side lot fence, the standard fence provides more privacy with narrower spacing between slats.

Standard Fence Requirements:

- Height: 5'
- Horizontal Slat Pattern (See Exhibit):
- 6" Slat-1" Space-4" Slat-1" Space-4" Slat
- Ground Clearance: 2"-4"
- Fence/Post Cap: 2" Lateral Slat (1" overhang)
- Post Spacing: 6'-0" O.C.

Alley Fencing Requirements:

- Fences must be offset (setback) a minimum of 2' from the garage face
- No fence shall be allowed within 5' from alley R.O.W. or access easement to provide landscape screening
- For lots less than 40' wide, all fences shall be recessed 2' from the garage facade

Post Footing

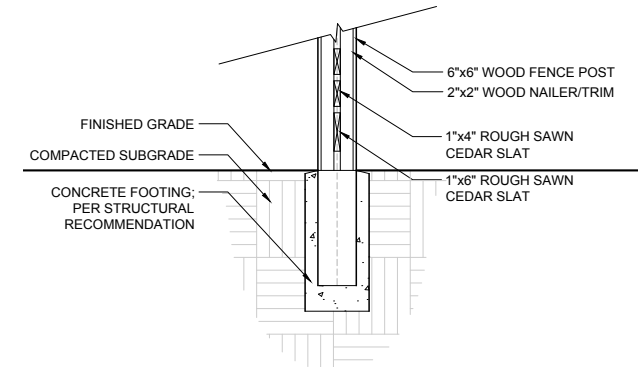

Post Swale Footing

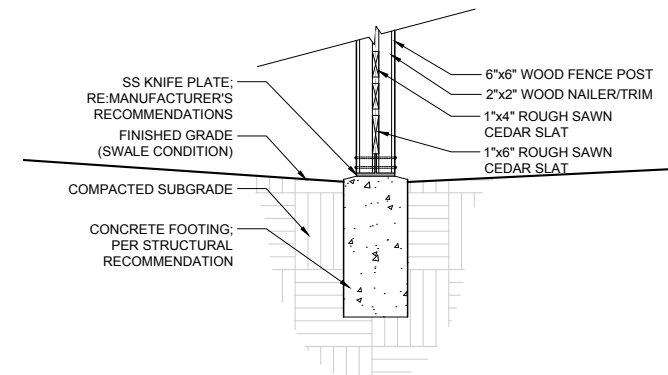

Post

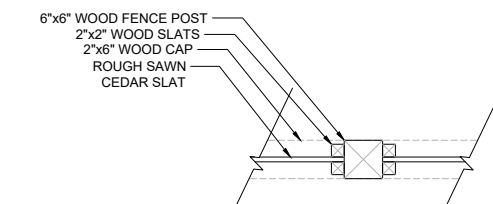

SITE IMPROVEMENTS

Standard Wood Fence

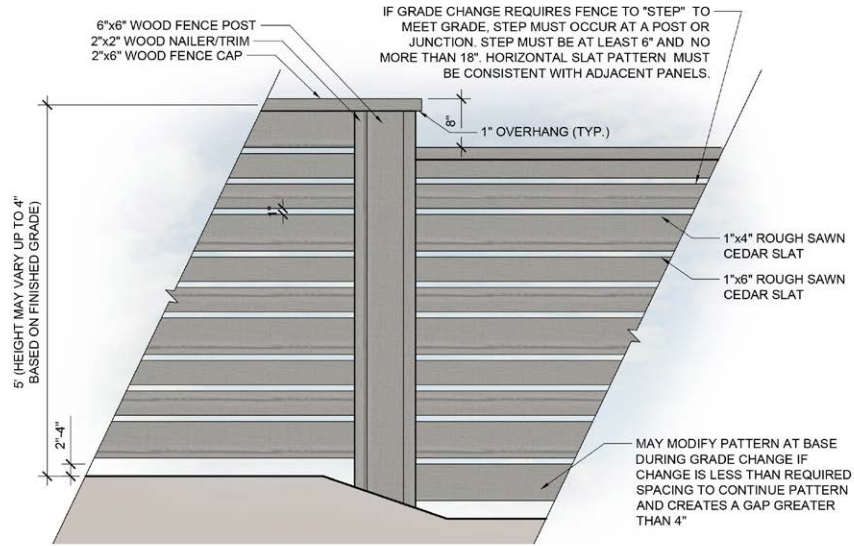

Wood Fence Gate

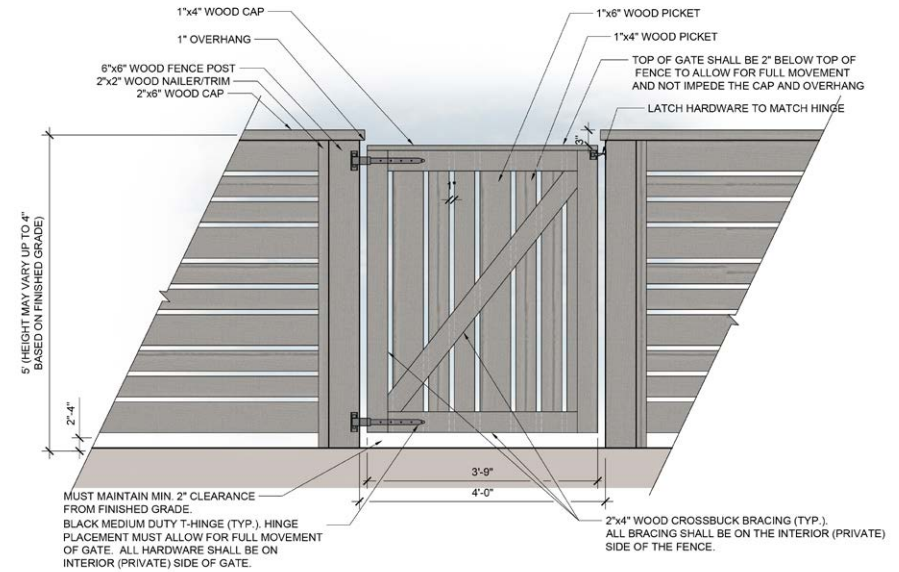

Enhanced Wood Fence (Corner-Side Lot, Side-Alley, Visual Terminus)

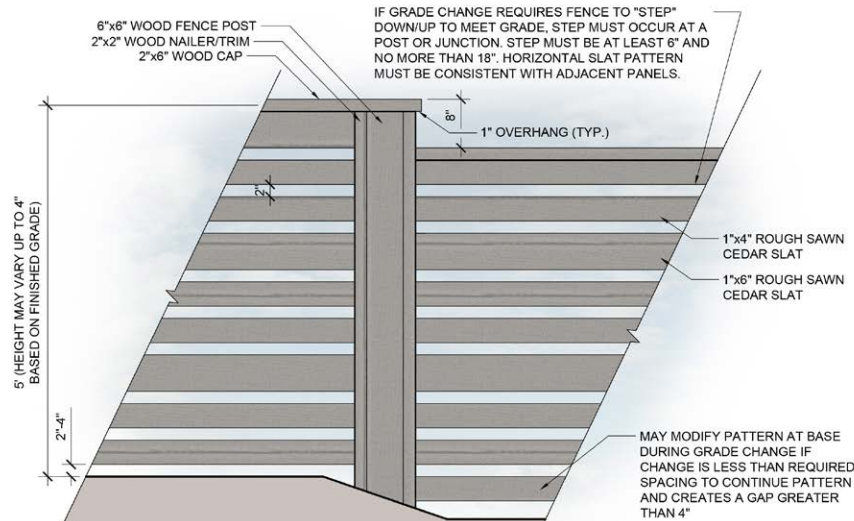

PLANTING LIST



Botanical Name

Common Name

Min. Size

Shade Trees

Platanus mexicana
Quercus muehlenbergii
Quercus polymorpha

Mexican Sycamore
Chinkapin Oak
Monterrey Oak/
Mexican White Oak

65 gal./2.5-3" cal.
65 gal./2.5-3" cal.
65 gal./2.5-3" cal.

Quercus virginiana

Live Oak (varieties include
Cathedral, High Rise)

65 gal./2.5-3" cal.

Quercus lyrata
Ulmus crassifolia

High Beam Overcup Oak
Cedar Elm

65 gal./2.5-3" cal.
65 gal./2.5-3" cal.

Ornamental Trees

Cercis canadensis

Redbud (varieties include
Oklahoma, Texas)

30 gal.

Ilex x Attenuata 'Savannah'

Savannah Holly

15 gal.

Lagerstroemia indica 'Natchez'

Natchez White Crape Myrtle
(3-cane min.)

30 gal.

Magnolia grandiflora

Magnolia (varieties include
Little Gem, D.D. Blanchard,
Sweetbay)

30 gal.

Vitex Agnus-Castus

Chaste Tree (3-cane min.)

30 gal.

Screening Planting

Feijoa sellowiana

Pineapple Guava

15 gal.

Ilex x attenuata

Holly (shrub form)

15 gal.

varieties include Eaglestone
East Palatka

15 gal.

Ilex vomitoria

Yaupon Holly (shrub form)
varieties include Pride of
Houston

15 gal.

Myrica cerifera

Wax Myrtle (shrub form)
varieties include Nana

15 gal.

Pinus taeda

Loblolly Pine (trees to be
mixed with shrubs)

30 gal.

Podocarpus macrophyllus

Japanese Yew

30 gal.

Prunus laurocerasus

Cherry Laurel

15 gal.

Viburnum suspensum

Sandankwa Viburnum

10 gal.



PLANTING LIST

Botanical Name	Common Name	Min. Size	Spacing
Shrubs			
Anisacanthus quadrifidus Wrightii	Flame Acanthus	3 gal.	30" on center
Buddleia davidii 'Dubonett'	Dubonett Butterfly Bush	3 gal.	30" on center
Buxus microphylla	Boxwood	3 gal.	24" on center
Callicarpus americana	American Beautyberry	3 gal.	30" on center
Callistemon citrinus 'Little John'	Dwarf Bottlebrush	3 gal.	24" on center
Cephalanthus occidentalis	Buttonbush	3 gal.	30" on center
Feijoa sellowiana	Pineapple Guava (shrub form)	5 gal.	36" on center
Ilex cornuta 'Carissa'	Carissa Holly	5 gal.	30" on center
Itea virginica	Virginia Sweetspire	3 gal.	24" on center
Malvaviscus arboreus var. Drummondii	Turk's Cap	3 gal.	30" on center
Myrica cerifera	Dwarf Wax Myrtle	5 gal.	24" on center
Podocarpus microphyllus	Japanese Yew var. 'Pringles'	5 gal.	30" on center
Sabal minor (rear yard, massing only)	Dwarf Palmetto	3 gal.	36" on center
Viburnum suspensum	Sandankwa Viburnum	5 gal.	30" on center
Viburnum obovatum	Walter Viburnum	5 gal.	30" on center



PLANTING LIST



Botanical Name

Common Name

Min. Size

Spacing

Perennials

- Agapanthus
- Asclepias incarnata
- Asparagus densiflorus
- Dianella tasmanica
- Dietes bicolor
- Eupatorium greggi
- Hesperaloe parviflora
- Liriope gigantea
- Plumbago auriculata
- Rudbeckia hirta
- Salvia

- Lily of the Nile
- Swamp Milkweed
- Foxtail Fern
- Flax Lily
- Bicolor Iris
- Greggii Mistflower
- Red Yucca
- Giant Liriope
- Plumbago
- Black-Eyed Susan
- Salvia, varieties include Indigo Spires

- 3 gal. 18" on center
- 3 gal. 18" on center
- 3 gal. 18" on center
- 3 gal. 18" on center
- 3 gal. 18" on center
- 3 gal. 18" on center
- 3 gal. 30" on center
- 3 gal. 18" on center
- 3 gal. 24" on center
- 3 gal. 18" on center
- 3 gal. 24" on center

Salvia leucantha 'Santa Barbara'

Santa Barbara Mexican Bush Sage

3 gal. 24" on center

Tagetes lucida

Mexican Mint Marigold

3 gal. 18" on center

Ornamental Grasses

- Muhlenbergia capillaris
- Muhlenbergia lindheimeri
- Panicum virgatum

- Gulf Coast Muhly
- Lindheimer Muhly
- Switch Grass, varieties include Shenandoah, Heavy Metal, Northwind

- 3 gal. 24" on center
- 3 gal. 36" on center
- 3 gal. 24" on center

PLANTING LIST

Botanical Name	Common Name	Min. Size	Spacing
Ground Cover			
<i>Ficus tikoua</i>	Sandi-Leaf Fig	1 gal.	12" on center
<i>Lantana montevidensis</i>	Purple Trailing Lantana	1 gal.	12" on center
<i>Lantana</i>	Lantana	1 gal.	12" on center
<i>Ruellia</i>	Mexican Petunia	1 gal.	12" on center
<i>Trachelospermum asiaticum</i>	Asian Jasmine	1 gal.	12" on center
<i>Wedelia trilobata</i>	Wedelia	1 gal.	12" on center

Turf Grass

TifTuf Bermuda (Sod only)

Vines

<i>Ficus pumila</i>	Fig Ivy	1 gal.	12" on center
<i>Gelsemium sempervirens</i>	Carolina jessamine	1 gal.	12" on center
<i>Lonicera sempervirens</i>	Coral Honeysuckle	5 gal.	4' on center
Rose	Rose, varieties include Madame Alfred Carriere (nearly thornfree), New Dawn, Lady Banks White	5 gal.	6' on center
<i>Trachelospermum jasminoides</i>	Confederate Jasmine	1 gal.	12" on center







DESIGN REVIEW PROCESS

BRIDGELAND CENTRAL TND



PROCEDURES & SUBMISSIONS

The Following Design Review Process text is extracted from the "Bridgeland Residential New Development Standards - Parkland" (3/16/2018). The full text is available online at: <<http://www.kenanderson.com/res-bridgeland>>

General

The process of submitting plans, specifications and samples to the Bridgeland Architectural Review Committee ("ARC.") is explained in this section. This process is intended as an instrument for insuring that builders maintain uniform conformance to the guidelines, which have been established to create a new town consistent with the Bridgeland Mission Statement. Within the stated time-period for review, a clear and direct statement as to acceptability of construction plans will be made to builders who make submissions in accordance with the standards.

The builder is solely responsible and liable for following the requirements of these Standards regardless of whether detail(s) of items are noted/called out on reviews/documentation including, but not limited to plans, permits, applications and inspections.

Scope of This Document

All new construction, subsequent construction, remodeling with exterior exposure, expansion, and demolition of structures within Bridgeland shall be reviewed and approved by the ARC, prior to commencement of any on-site building or construction activity. The ARC may consider any and all exterior elements of design including, but not limited to, size, massing, architectural style, colors, materials, harmony of design and other factors that, in the opinion of the ARC, affect the appearance of the improvement(s) and/or their compatibility with surrounding development.

This document specifically applies to the activities of Builders constructing new homes on lots on which there are no existing structures. A separate yet similar document will govern subsequent activities by homeowners or builders on lots once the initial construction activities have been completed.

PROCEDURES & SUBMISSIONS

Procedure

The review process begins when a Builder submits an online application including a set of plans, drawings, specifications and other required information to the ARC for processing. Submissions shall be made using the website below:

www.KenAnderson.com

Office: 281-367-5430

Required Submission Information

The builder is required to submit the following information to be reviewed by the ARC.

A. Architectural

- Floor plans and (all) exterior elevations.
- Outline specifications with materials/ colors list clearly referenced to location.
- Statement of House Square Footage. Note that ALL air-conditioned interior space, including, but not limited to, granny flats, shall be measured from interior stud to interior stud and be included in the house square footage.

B. Site plot plan drawing including the following information:

- Village Name, Neighborhood Name, Section Number, Block Number, Lot Number.
- Right of way, minimum setbacks & easements.
- Actual footprint of house and garage, with dimensions of main elements from property line

- Driveway, patios, walls and any other flatwork, fully dimensioned
- Utility service locations
- Total area of all footprint areas of impervious cover including house and garage footprint
- Location, height and material of each exterior fence or wall
- Any proposed freestanding exterior lighting, including fixture cuts including locations, mounting heights and manufacturer's catalog photographs of proposed fixtures.
- Any temporary construction facilities such as trailers, storage locations, fences, temporary signs, lights, model home parking lots, etc.

C. Master Plans

- In order to provide the shortest turnaround time for reviews the following shall be required. When submitting Master Plans for review, builders will submit each elevation as a separate submission. Each Master Plan (elevation) submission shall only include the plans, elevation, option, etc. sheets that pertain to that particular Master Plan (elevation).

PROCEDURES & SUBMISSIONS

Quality of Submission Content

It is in the interest of both the Builders and the Developer that this process be a smooth and timely one. Towards that end, the approvals can be facilitated if complete and high-quality documentation is provided to the ARC. When an Application is received, it is reviewed for completeness. An Application that is not complete and/or not clearly readable will be returned with an explanation of the reasons for this action. A complete Application will be processed and reviewed by the ARC.

Submission Timing

Submissions to the ARC for approval may be made at any time. Responses will generally be made within seven (7) business days from receipt of a completed online application (including all applicable supporting and required documents in electronic format), however there is no time restriction and lack of response shall be deemed a rejection.

Submission Fees

Nominal fees may be established by the Developer in the future to help defray the expenses associated with the review of improvements. The fees are adjusted from time to time and are based on the complexity of the project proposed. A list of current fees can be obtained from the Developer's office.

ARC Action on Submittals

The approval process is intended to minimize hardship or undue delays, while facilitating the common goals of the Builders and the Developer. Every effort will be made to review and act upon applications as soon as possible after they are received.

Notice of Approval, Conditional Approval or Disapproval of each submission will be returned to the Applicant via email or other electronic means which the ARC deems appropriate. Construction may proceed immediately following receipt of written Final Building Permit Approval from the ARC.

Expiration of Permits

All approved or conditionally approved permits shall be exercised within one (1) year from the date of approval, or the permit shall be null and void.

Variations

Variations to these Standards may be granted by the ARC. Any variance granted will only be applicable to the specified site and conditions for which the variance was granted, only if it has been identified in writing on the submitted plan and specifically approved in writing by the ARC. Granting of such a variance will not modify or change any standards as they apply to other lots or conditions.

PROCEDURES & SUBMISSIONS

All variances shall be exercised within one (1) year from the date of approval, or the variance shall be null and void. Upon an application, which must be submitted in writing thirty (30) days prior to the expiration and for good cause, the ARC may grant an extension of time not to exceed one (1) year.

Appeals

Every aspect of a proposal is carefully weighed and most projects are approved. If a proposed submission is not approved by the ARC, the applicant may appeal the decision to the ARC in writing within ten (10) days of receipt of the ARC decision. Appeal can be made by addressing a letter to the ARC stating the decision being appealed and the specific objection to the decision. The ARC then hears and rules on appeal as promptly as possible. All decisions of the ARC are final.

Construction Timeline

Construction of dwellings, which have received prior written approval or conditional approval by the ARC, shall commence within one (1) year of the permit date and shall be completed within:

- Production Home - One (1) Year
- Custom Home - Two (2) Years

The ARC may grant an extension for construction on a case-by-case basis, but the request for an extension must be made at least thirty (30) business days prior to the conclusion of the completion deadlines noted above.

Failure to complete a home within the designated time period may result in a penalty or fine to be drawn from the builder's construction deposit and/or damage deposit.

Final Compliance Inspection Procedures, Penalties, and Variances

A representative of the ARC must inspect the improvements to verify that they have been constructed in conformance with the Covenants, the approved plans and these Development Standards. The Final Compliance Inspection represents a selected portion of these Development Standards; it should not be considered as a total approval of these Development Standards. Inspections conducted by Bridgeland, the ARC and/or Ken Anderson & Associates are aesthetically based only and in no way, include inspections pertaining to code compliance or to the integrity of the home and/or improvements. Builders are solely responsible and liable for ensuring that all construction and/or improvements meet or exceed all applicable codes, good building practices and comply with all local and federal regulations, laws, etc. Each builder is ultimately responsible to make sure every home is built to be in full compliance with these Development Standards.

PROCEDURES & SUBMISSIONS

A. Inspection Procedures and Penalties

- Request for Initial Final Compliance Inspection

Once a home is completed, each Builder is responsible for making a request to the ARC for a Final Compliance Inspection, using the online request services at www.KenAnderson.com. Request for a Final Compliance Inspection must be made at least seven (7) days before the home closes.

A final survey (including all fences, pools and other installed improvements) must be submitted to the ARC at the time the Final Compliance Inspection request is made. Anyone who fails to meet the requirements will be subject to a five-hundred (\$500.00) dollar fine, which may be deducted from the Builder's construction deposit and/or damage deposit.

If the property does not pass its initial Final Compliance Inspection, the builder will have ten (10) working days to correct all items listed on the Final Compliance Inspection report. It is the builder's responsibility to request a re-inspection once the necessary corrections have been completed otherwise a re-inspection will be conducted automatically after the ten (10) working days have expired.

- 2nd Final Compliance Inspection (Re-Inspection)

If the property does not pass its 2nd Final Compliance Inspection, the builder will have ten (10) working days to correct all items listed on the Final

Compliance Inspection report. It is the builder's responsibility to request a re-inspection once the necessary corrections have been completed otherwise a re-inspection will be conducted automatically after the ten (10) working days have expired.

- 3rd Final Compliance Inspection (Re-Inspection)

The property will be inspected one final time. If all outstanding items have not been corrected, the following will occur:

- The builder will be issued a Final Compliance Inspection verdict of "Closed Non-Compliant" and a copy will be sent to the Bridgeland HOA.
- All New Construction Submittals/ Building Permits (starts) will be put on hold company-wide until all outstanding inspection items are brought into compliance.
- Responsibility for bringing all outstanding items into compliance will be transferred from the builder to the Homeowner and resolution may be enforced through the HOA as a request to comply with the New Construction Development Standards.
- When necessary the HOA will inform the Homeowners that the home was inspected multiple times to allow the builder to bring the outstanding items into compliance, and that it was the Builders responsibility to make sure that all construction requirements were met before the home closed.

PROCEDURES & SUBMISSIONS

Remedies

Additional remedies and enforcement rights exist under the Covenants. The ARC may file suit to obtain an injunction mandating compliance with the Covenants and the Standards. The ARC has the further right, after proper notice to the Owner, to go onto the property where a violation exists, fix or remove the violation, and collect any costs incurred from the Owner.

Changes in Review Process

The ARC reserves the right to alter the review process in order to ensure an adequate review of all submissions while reasonably accommodating the needs of Builders.

Governmental Regulations

The Covenants and these Development Standards are not intended to permit any action prohibited by applicable laws, rules, or regulations of any governmental authority. Where these Standards contain requirements in addition to or more restrictive than applicable governmental laws or regulations, the provisions of these Standards are binding and enforceable, and prevail over the requirements of such laws or regulations unless these Standards are expressly made unenforceable by law or judicial decisions.