

BRIDGELAND CENTRAL

EASTHAVEN

DESIGN
GUIDELINES
FEB | 2026

Howard Hughes[®]

Howard Hughes Holdings
Bridgeland
23720 House Hahl Road
Cypress, TX 77433
281.213.1100



DTJ Design
3101 Iris Avenue, Suite 130
Boulder, Colorado 80301
303.443.7533
www.dtjdesign.com



These design guidelines are intended to help direct qualified architects, owners, builders, and their representatives towards a unified community and architectural character defined as "Adaptive Re-Use". These guidelines describe a framework and design aesthetic that promotes a consistent and recognizable solution. Creativity is encouraged to create a customized solution as long as it reflects the ideas and character described within the following pages.

These guidelines do not represent an exhaustive design methodology but rather are meant to be an inspiration for quality, thoughtful and innovative approaches to architectural styles within the boundaries of a consistent and recognizable "Adaptive Re-Use" character.

No part of this document may be reproduced, stored in or introduced into a retrieval system, or transmitted, in any form, or by any means (electronic, mechanical, photocopying, recording, or otherwise) without prior written permission of the owner and designer (DTJ DESIGN Inc.)





TABLE OF CONTENTS

1.5

[I.] Introduction

- How to Use These Guidelines
- How These Guidelines are Organized
- General Provisions
- Site Overview
- Architectural Character

[II.] Architecture Design Criteria

- Adaptive Reuse Style
- Universal Architectural Criteria
- Unified Diversity

[III.] Site Plan & Lot Criteria

- Unique Site Conditions
- Lot Requirements
- Streetscape

[IV.] Landscape Design Criteria

- Overall Design Intent
- Site Improvements
- Landscape Requirements
- Fencing + Gates
- Fundamentals + Water Conservation
- Lighting

[V.] Design Review Process

- Procedures & Submissions

HOW THESE GUIDELINES ARE ORGANIZED

Introduction

The introduction component provides the purpose and focus of Bridgeland Central Easthaven Design Guidelines. This section is the foundation of the document and contains information related to design intent and character.

Architecture Design Criteria

This section describes the architectural image for Easthaven, derived in direct response to physical and climatic influences that reflect an urban environment. Architectural guidelines have been drafted to assist architects and builders in designing architecture in which the building mass, roof form, architectural elements, materials, and colors are appropriate for Bridgeland Central Easthaven.

Site Plan & Lot Design Criteria

Site planning guidelines for Easthaven are designed to promote a vibrant and interesting character and ambiance for this planned community through the intentional siting and orchestration of homes within this unique environment. The site planning section includes creative design criteria while balancing new development and the creation of an interesting community fabric.

Landscape Design Criteria

This section provides specific guidelines that have been established to promote planting designs that are well adapted to the region, resulting in indigenous landscapes that grow and function utilizing less energy, water, fertilizer, and maintenance. Another major objective of this section is to assure that individual lot landscapes harmonize with adjacent lots and open space areas, promoting a cohesive and flowing relationship.

Landscaping requirements are extensive and larger plantings may be required at specific locations fronting the master developer rights of way, open space reserves and spine roads. Lot owners are strongly advised to review these requirements in advance of construction of their parcel(s) and to budget approximately 5% or more of their total construction budget to landscaping costs.

Additionally, within the landscape section, these design guidelines provide prototype options for interior yard designs the builder(s) may chose to offer as upgrades for individual units.

Design Review Process

The Design Review Process is an integral part of ensuring that Bridgeland Central Easthaven is developed as a comprehensive and intuitive community. This section outlines the process and any requirements for builders within Easthaven.

Who uses These Guidelines

We believe that the physical appearance of the site, architecture, and landscape is critical to the success of any community. Achieving a healthy and vibrant image is the goal of these guidelines. These guidelines advocate a strong and consistent community design vision at Bridgeland, with architecture and landscaping both fresh and timeless. To that end, we have established this Design Guideline document to assist the architects, owners, builders, and their representatives in creating residential homes and landscapes that are consistent with this goal.

Amendments & Supplements

This Bridgeland Central Easthaven Design Guideline document may, from time to time, be amended or supplemented by the Master Developer at its sole discretion. Any such amendments shall be applicable to all development plans that are subsequently submitted for review and approval to the Master Developer and Architecture Review Committee ("ARC").

Approvals

Unless otherwise explicitly provided herein to the contrary, all approvals shall be in writing and may be granted or withheld at the sole discretion of the Master Developer or ARC. Any approval pursuant to these Design Guidelines does not constitute a warranty, assurance, or representation by the approving party; and the approving party shall have no liability as a result of such approval.

Waivers

The Master Developer (Howard Hughes Holdings Inc.) or the ARC shall have the right, from time to time, to waive, at its sole discretion, any provisions of this Design Guideline document as may be applied to any specific site, architectural, or landscape plan. No such waiver shall be construed or held to be a waiver of any provisions of this Bridgeland Central Easthaven Design Guideline document, or of the same provisions as to any other party.

Regulation Compliance

In addition to these Guidelines, builders and lot purchasers (and their consultants) at Bridgeland Central are expected to meet all the criteria established by both the overall Bridgeland Community and the City of Cypress, Texas.

All development within the Bridgeland Central Easthaven shall comply with the codes and regulations of all Local, State, and Federal bodies and agencies, including, but not limited to, Bridgeland Guidelines, as well as the City of Cypress, Texas building codes. All development shall also comply with the Declaration of Covenants, Conditions, and Restrictions (CC&R's) adopted for Bridgeland.

The Bridgeland Central Easthaven Design Guideline document may be more restrictive than, but does not supersede or modify any existing City, County, or State codes or ordinances. In the event of conflict or discrepancy, or for subjects not addressed herein, the most restrictive standards shall apply.

SITE OVERVIEW

Bridgeland Master Plan

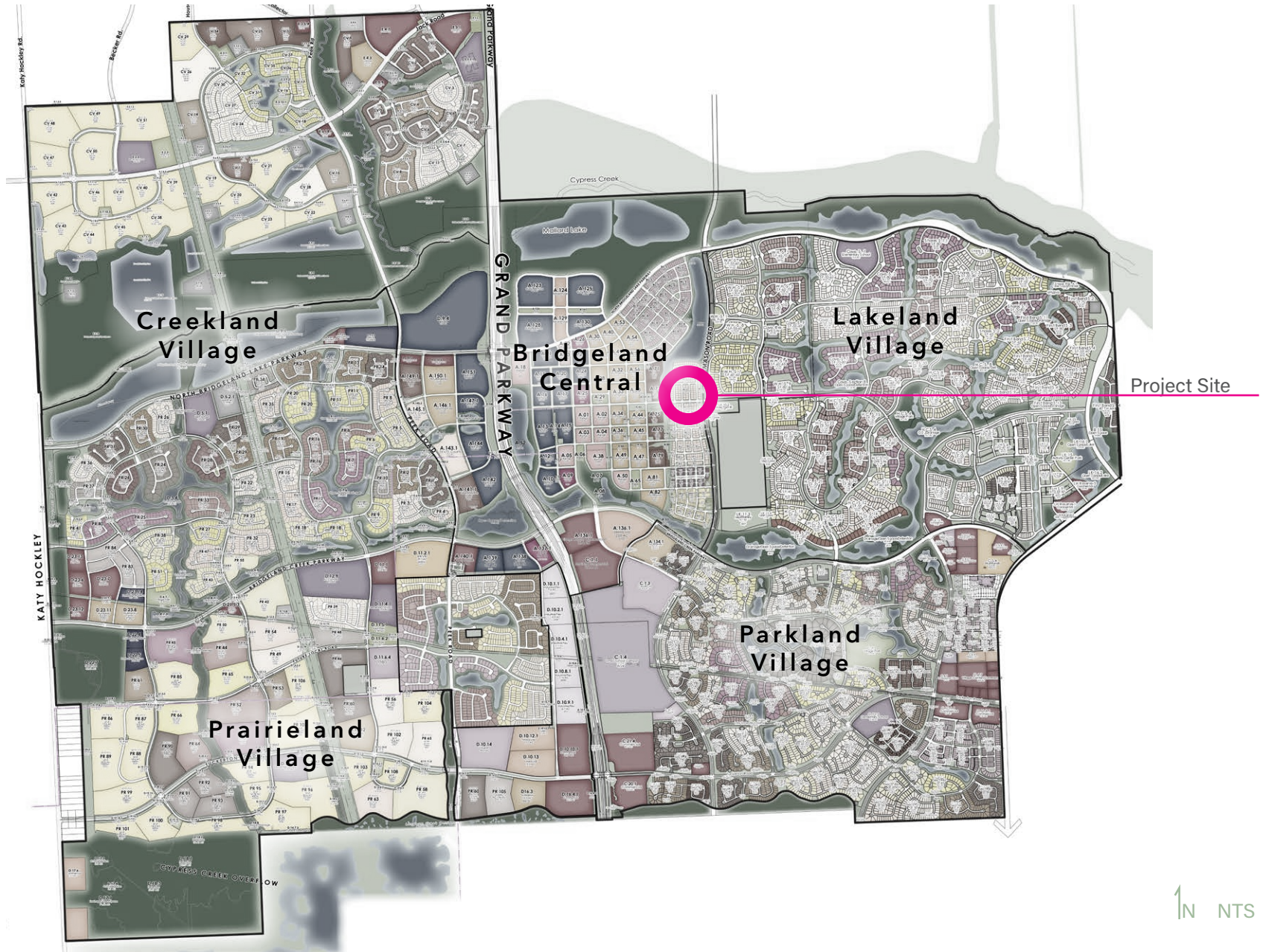

EASTHAVEN SITE PLAN

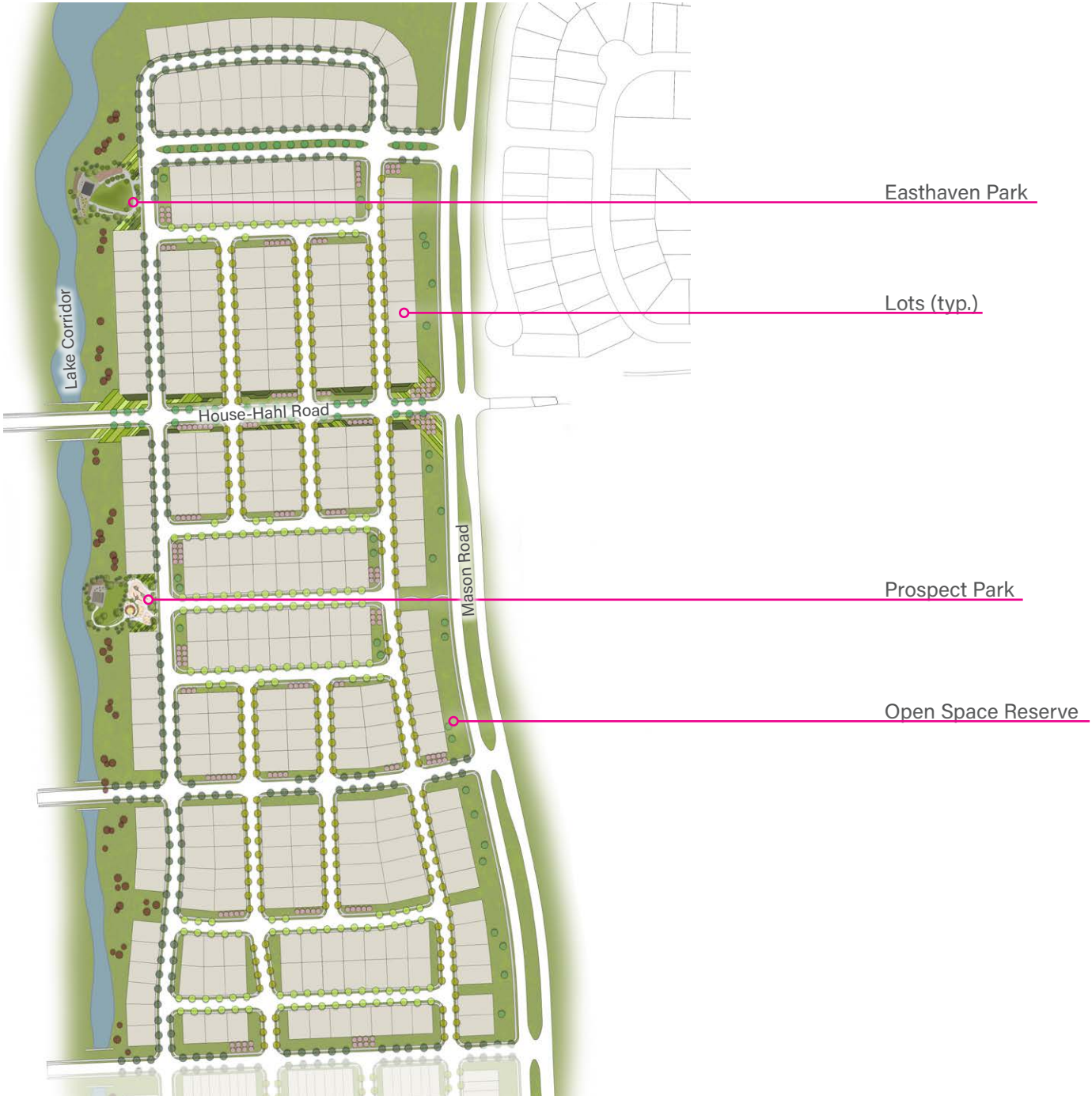

ARCHITECTURAL CHARACTER: ADAPTIVE RE-USE



CHARACTERISTICS OF ADAPTIVE RE-USE

Similar to the charming brick storefront architecture of the early 1900s, the Adaptive Re-use style integrates town-center materials with familiar architecture forms. Building projections, window patterns and materials create hierarchy and rhythm to unify Bridgeland Central. The style is meant to reflect a “built over time” quality. Unique projections, window patterns, and materials reflect modern materials and styling to appear as “renovations” or “additions” to otherwise simple and traditional forms that appear as though from a different time; in this manner, an adaptive re-use language is created that reflects a visually juxtaposition of elements in new construction.

Key Elements:

- 1 Masonry bases ground the buildings and provide continuity at street level.
- 2 Building projections vary and create interest within the composition.
- 3 Window packages and arrangements are repeated for consistency.
- 4 Unit entries are expressed with urban design elements like recessed entries, window awnings or small stoop roof forms.
- 5 Roof forms incorporate some pitched or flat elements that reflect re-use character.
- 6 Style appropriate door is painted an accent color.
- 7 Grouped windows are encouraged for a more urban character - this can be achieved with trim, accent siding or color blocking.

ADAPTIVE RE-USE DESIGN SPECTRUM

In order to enhance the Bridgeland Core context, which will be urban in nature, the Adaptive Re-use style may be expressed in various ways to relate to a parcel's immediate context.



TRADITIONAL

The overall form and massing is familiar, and includes roof pitches and design elements similar to conventional styles, but **windows packages** are grouped together to become strong visual components at key “renovated” areas. Similarly, some **materials** have been “re-sided” to reflect today’s preferences and become strong focal points, while the “original” siding creates a more subdued background material.

TRANSITIONAL

The overall form incorporates flat roofs for a more urban look and feel. Colors and materials are more **muted** and create a consistent streetscape. Windows are more **atypical** in size and proportion. Building projections appear as “additions”, along with other building elements which interrupt the traditional streetscape look and feel.

STYLE IMPLEMENTATION: ATTACHED

I.13



Example above illustrates an attached product featuring key elements. The forms and materials reflect a [transitional](#) style interpretation for reference. In addition to the key elements found on the "Characteristics" page for this style, attached homes must also incorporate the following key elements:

1 Single family home entrances are clearly defined.

2 Single family home articulation occurs in plane depth, roof forms, and window patterns.

3 Single family home reflect consistent materials and detailing.

4 Windows are thoughtfully placed and grouped together for a more modern appearance.

VISION IMAGERY: ADAPTIVE RE-USE



All images are for inspiration purposes only and are meant to represent different design elements and components for each style & interpretation.

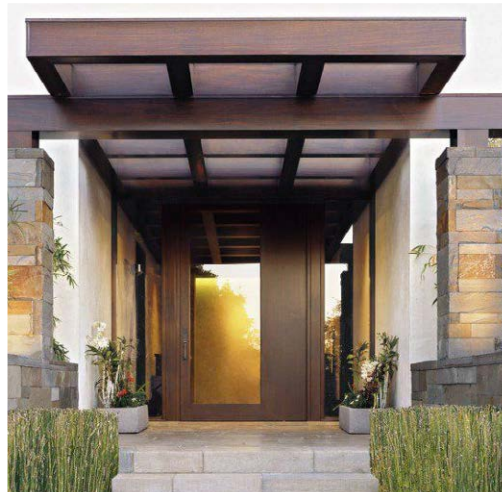

All images are for inspiration purposes only and are meant to represent different design elements and components for each style & interpretation.





ARCHITECTURE DESIGN CRITERIA

BRIDGELAND CENTRAL EASTHAVEN

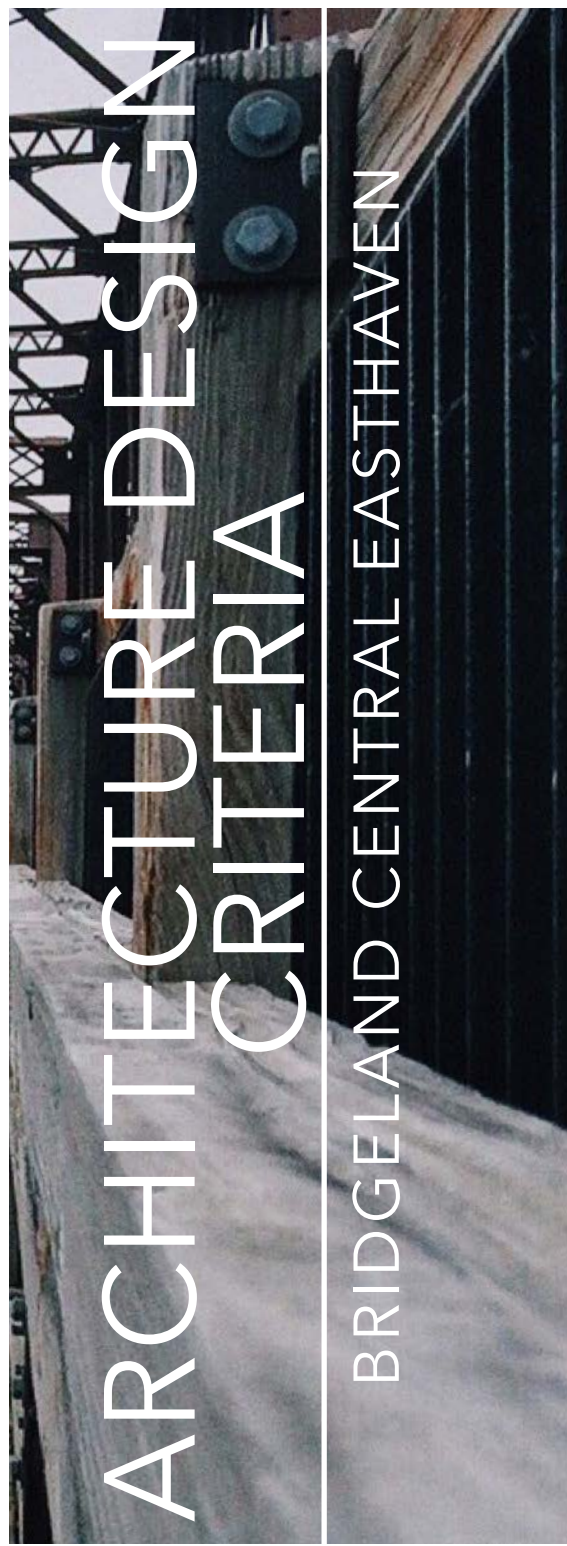

STYLE: ADAPTIVE RE-USE

Image + Character

As a transitional neighborhood near the Birdgeland Central Core, Adaptive Re-Use style is intended to create the impression of a neighborhood developing over time. The clean, simple, light-weight, contemporary designs of industrial architecture strengthen the sense of a cutting-edge community.

This style is signified by strong, simple geometries, exposed (and often highlighted) details and structural supports, and cool, austere color palettes. Contemporary Adaptive Re-Use architecture uses large groups of windows, centered on a mass, to bring in light and accentuate large volumes.

Inspired by historic architecture, Adaptive Re-Use style should feel “light.” Soaring roof lines lifted by slender steel supports bring the viewers’ eyes skyward, emphasizing the historic precedent and context.

Identifying Elements

Adaptive Re-use style trends toward utilitarian. Strong, durable, stable materials and massing. Use of clean, simple geometry helps to enhance utilitarian materials.

Common Adaptive Re-Use elements include:

- 1 Large groups of windows centered on a mass
- 2 Metal accents and Paneled Siding
- 3 Wedge or Flat roofs to highlight form
- 4 Exposed structural elements
- 5 Awnings with tie rods
- 6 Color Blocking
- 7 High Contrast with vibrant color accents



Wedge or Flat Roof



Large clean windows with sleek lines



Metal Details and Brackets



Clean, modern columns

ADAPTIVE REUSE

11.19



Exposed beams with modern downspouts & metal trim.

FORM: ADAPTIVE RE-USE

Roof Forms + Massing

Adaptive Re-Use massing tends to be efficient to create usable interior volumes. Facade breaks, material changes, and secondary masses are required to create visual movement on the exterior architecture. Upper story masses shall appear lighter (with less bulk) than the lower story. Flat, barrel, hip, or butterfly roof forms are required for this style.

A visible main-body roof form shall be used in conjunction with complementary minor roof forms and elements. Minor roof elements such as gable ends and dormers shall be proportional to the spaces they cover and to the overall roof size and form.

The use of building projections, one story building elements, roof skirts, decks, and covered porches to soften facades is required on corner and enhanced elevations and is encouraged on rear elevations.

Roof + Overhang Details

Adaptive Re-Use roof forms may take their inspiration from pragmatic industrial buildings (emphasizing efficiency and maximizing volume) or more contemporary forms (focusing on “light weight” appearance and “soaring” aesthetics). In both conditions, it is important to ensure that the roof form reflects the overall massing of the building (soaring roof forms on single-story elements may be in visual conflict with the massing).

Use closed soffits for Adaptive Re-Use style buildings. Rafter tails are inappropriate on this style but structural support beams may provide visual interest to an otherwise monolithic form. Additionally, exposed materials on the underside of the soffit are appropriate for the style. On an Adaptive Re-Use style building, the underside of the soffit may be used as an accent element by using a contrasting material or color.

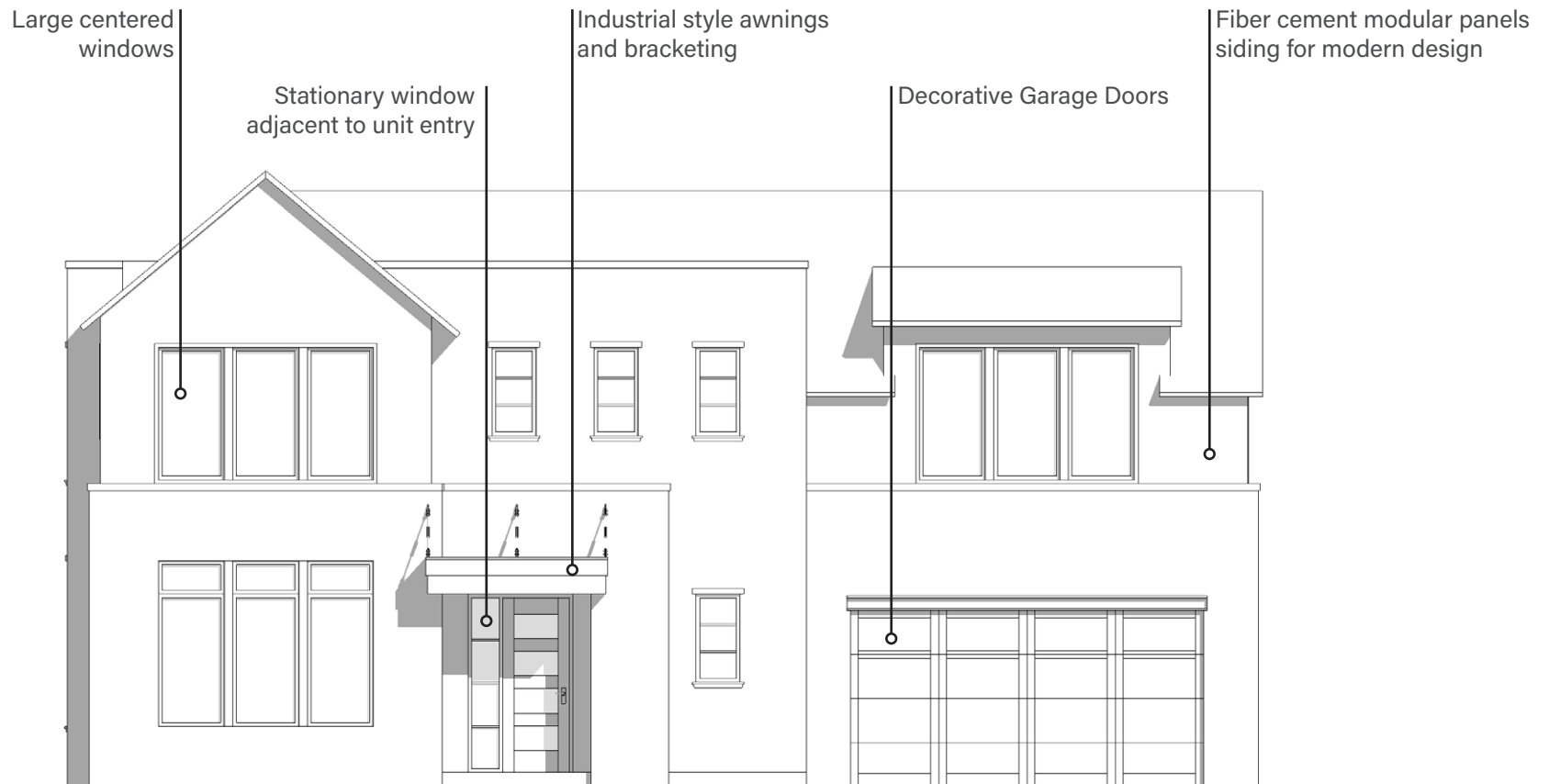

Technical Requirements:

Roof Slope(s):

Hip (2:12-4:12); Flat, Barrel, and butterfly roofs have no minimum slope requirements but shall be applied in consideration of overall massing and proportion;

Roof Overhangs:

2' maximum (unless utilized to cover an outdoor space).

FENESTRATION: ADAPTIVE RE-USE

Fenestration, Windows & Trim

Adaptive Re-Use style elevations should employ large window packages and group windows centrally on masses. Accent windows may wrap corners to bring attention to an important mass or architectural detail. Shape and orientation of windows (composition and orientation of mullions and muntins) should emphasize form and mass of the building. Windows shall have minimal framing (white vinyl may not be appropriate for this style unless approved as part of the color scheme). Muntins may be asymmetrical but should have pattern and rhythm. Operable windows shall be single-hung, with exceptions for windows above kitchen sinks, bathtubs, and showers.

Entryways

The treatment of the main entry is important to the success of the design. The entry should be highlighted with architectural elements to draw attention. Front doors should employ bright colors, industrial materials, and simple designs to accentuate the entries of a building. Bright color may be used to contrast with the architecture to imply that the door is a focal point without additional ornamentation. Front doors have windows unless accompanied by a side light.

Address markers should be bold, modern, strong markers that accent the Adaptive Re-Use style and shall be mounted to the front facade of these homes. Only painted, electroplated or weathered metal markers are permitted.

ADAPTIVE REUSE



Fenestration



Entryways



STRUCTURE AND ACCENTS: ADAPTIVE RE-USE

Building Projections

Buildings shall be articulated with appropriate projections that emphasize the style. Decks, balconies, bay windows, and other projections shall use industrial materials, details, and supports to accentuate the architecture and create focal points. Where appropriate, provide shade or overhead covering.

Structural Accents

In many ways the Adaptive Re-Use style is defined by the details more than material applications and form. Beyond the details and elements previously discussed, it is important that all exposed details be style appropriate. Connections between differing materials should be celebrated and, where appropriate, over-sized. Overall, details shall be clean and functional.

Columns & Beams

The Adaptive Re-Use style building are intended to appear light-weight; therefore, cantilevers are an appropriate alternative to columns and beams in some applications. The appearance of columns and beams should never be bulky. Use low profile materials, such as metal, to achieve stability while maintaining the light-weight nature of Adaptive Re-Use style. Additionally, columns and beams may be used as accent elements by elongating or otherwise exaggerating the proportions to draw attention to the structure.



Building Projections



Structural Elements



Column & Beams



OUTDOOR AREAS, RAILINGS, + FENCES: ADAPTIVE RE-USE

Decks, Porches, & Patios

Adaptive Re-Use allows for the most flexibility for outdoor space integration. Primarily, porches and patios are covered by an extension of the existing roof, by a secondary roof that mimics the building's roof form and proportion, or by an accent projection. Generally, decks, porches and patios should be located and designed to be an extension of the interior of the building, creating ease of access and visual continuity. Materials, colors, and details should be consistent with the architecture of the building. See universal architectural requirements (end of this chapter) for additional dimensional requirements.

Railings & Posts

Railings and posts shall reflect the style of the building. In Adaptive Re-Use applications, post and railings shall be made of metal or masonry and shall have minimal ornamentation. Details shall be clean and functional. Horizontal or vertical cable and steel mesh patterns are appropriate for Adaptive Re-Use style. Additional details, like tie rods and other connection systems may be used as part of the overall composition.

Fences

There are two primary types of fences:

Standard Fences (Wood), and Open View Fences (Steel). (see landscape design criteria chapter of these design guidelines regarding fence details, dimensions, and specifications). The standard fences are wood with a horizontal slat pattern. Open view fences are used at the side and rear of lots adjacent to the Lake Corridor.



Railings | Posts

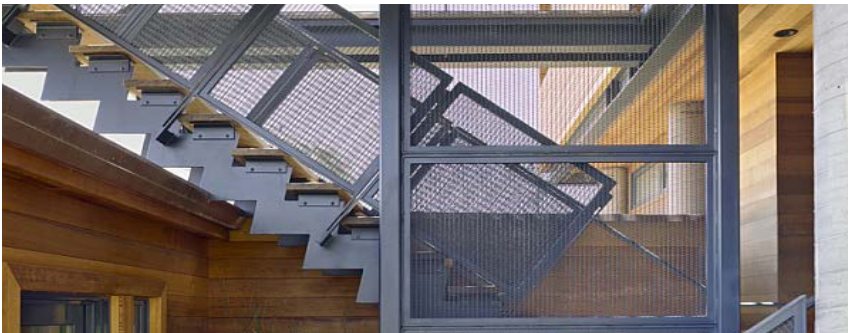

Fences



All standard fences shall adhere to the below requirements:

- Height: 48" average height (height may fluctuate up to 3" based on finished grade).
- Post Spacing: 72" O.C. (maximum). Distance between posts shall be consistent along a plane.

When transitioning between grades greater than 4", fences shall step (rather than slope). If more than one step is required, steps shall be consistent. Step height shall not create an interruption in the pattern or design of the fence (patterns shall be visually consistent).

The aesthetic fences shall reflect the architectural style of the building(s) with which they are associated.

All fences are subject to ARC approval.

MATERIALS + COLORS: ADAPTIVE RE-USE

Fascia Application

Material application can drastically affect the appearance and authenticity of a style. For Adaptive Re-Use style buildings, while structural elements and detail should be highlighted and exposed, the application of fascia materials should have minimal ornamentation. Fasteners and other material anchoring details should be concealed where possible. Exceptions to this rule can be made in instances where the fasteners are part of an architectural enhancement (all exceptions are subject to review by the ARC).

Colors:

The strategy for color application on Adaptive Re-Use is to employ high-contrast hues (black/gray/beige/white) with cool colors and natural textures to add accents and break up massing. Bright colors and warm colors should only be used to highlight significant elements, such as doors.

Appropriate Materials:

Siding:

- CMU Block (Smooth face)
- Cut Stone (Smooth face)
- Concrete (Board-form)
- Concrete (Smooth)
- Fiber Cement Panel
- Metal Panel (neutral color)
- Stucco
- Brick

Roofing:

- Composite Shingles
- Standing Seam Metal
- Corrugated Metal
- Light-Color TPO

Columns:

- Steel
- Masonry
- Concrete

Inappropriate Materials:

Siding:

- Lap Siding
- Metal Panel (bright color)
- Vinyl

Roofing:

- Tile
- Wood Shake

Columns:

- Exposed Wood

ADAPTIVE REUSE

Industrial and clean materials

Material Application



Metal Roof Overhang



Corrugated Metal (Painted)



Accent Trim



Stucco

Color Application



Matching complementary muted tones



Trim color



Secondary color



Accent material color



Primary color

Technical Requirements:

- No material shall terminate on an outside corner. Materials on a public facade shall terminate on an interior corner.
- For enhanced elevations, additional accent materials architectural features, and details contributing to the overall aesthetic are required. Enhanced elevations shall be subject to approval by the ARC.
- Use of materials not listed in "approved materials" list is at the discretion of the ARC.

UNIVERSAL ARCHITECTURAL CRITERIA

■ Side Architecture

- Side Architecture shall reflect continuity of style and avoid large blank walls
- Changes in facade materials shall be accompanied by changes in wall planes
- Wrap window treatments around corners

■ Side Entries

- When using side entries, tailor towards interior courtyard entries.
- The side elevation should be composed to reflect the architectural style and seamlessly accommodate the entry.

■ Facade Enhancements

- Wrap corner with overhangs/awnings to pull style from the front elevation to side elevation
- Decorative railing and window trim should be apparent and match style

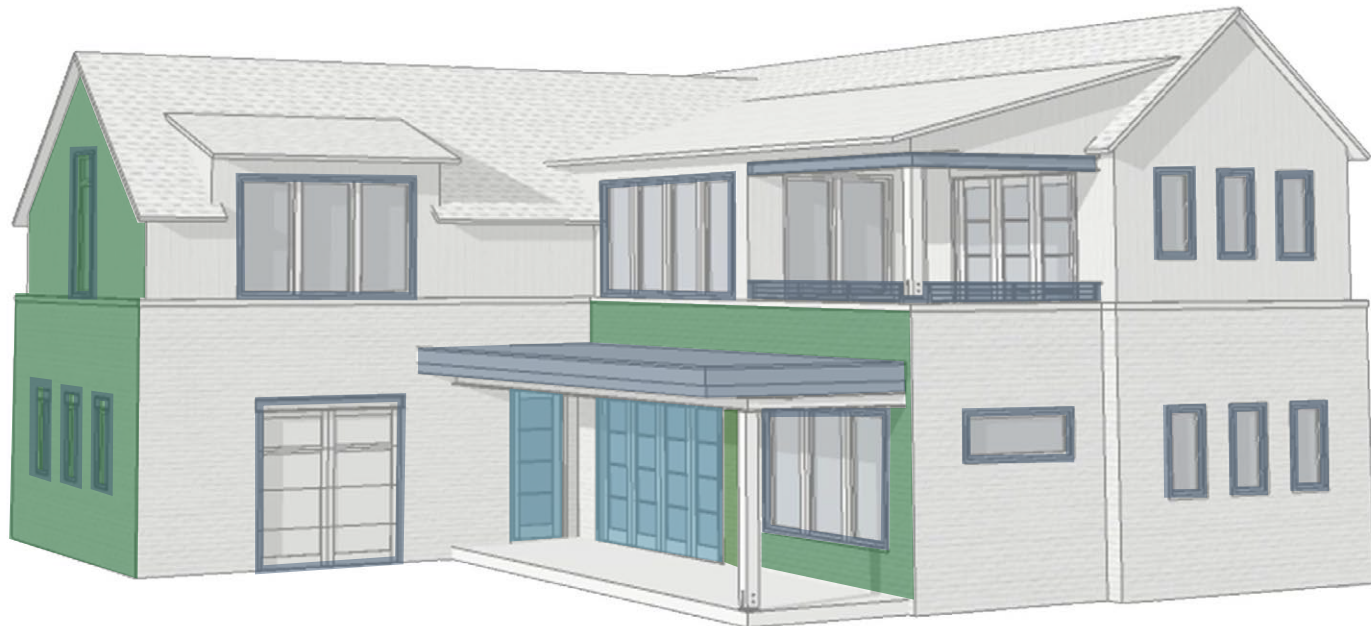

Integrating Front Porches & Entries

- Integrate steps and site walls to create interesting site elements. Return steps to a site wall where possible.
- Integrating stairs into planting beds or site walls will create an entry closer to the street blending private space and public space.
- If porch to adjacent grade is greater than 14", steps are required to be integrated (no "tack-ons").

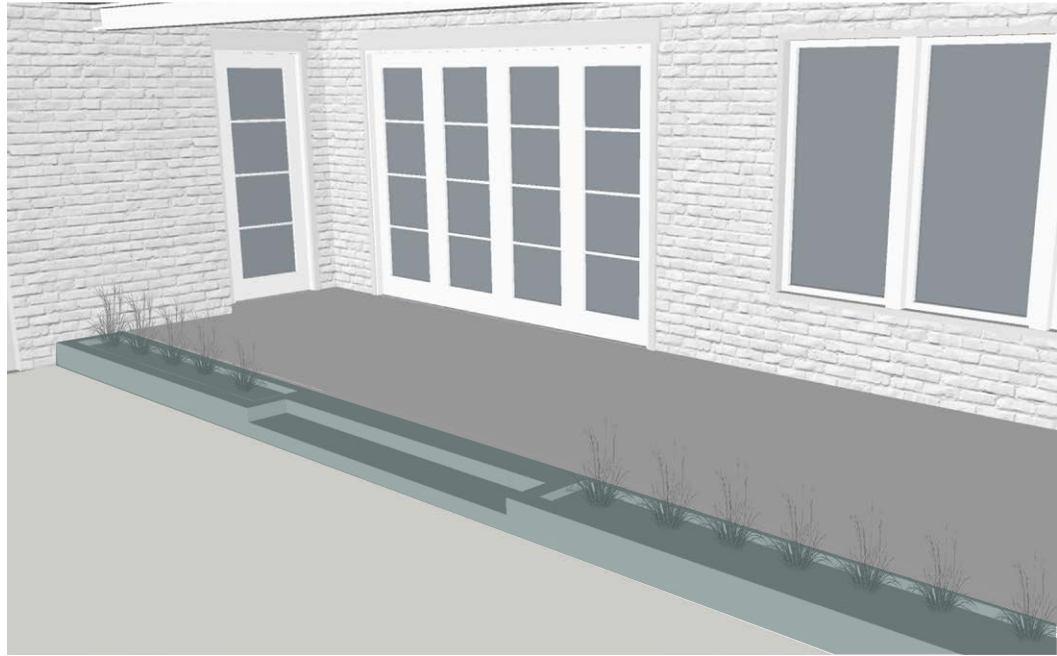

UNIVERSAL ARCHITECTURAL CRITERIA

■ Facade Articulation

(on Publically-visible elevations) :

- Facade breaks at least 2' offset from the adjacent plane are required a minimum of twice on any given facade or once every 15' (whichever is more); facade breaks are required at all entrances.
- A minimum of one window on each elevation shall be encouraged.
- Where materials occur at a corner of front elevation, they shall wrap the corner and terminate at an inside corner on the side elevation.
- All buildings shall require facade articulation on front and rear elevations to discourage a box-like appearance (side elevation articulation is encouraged).

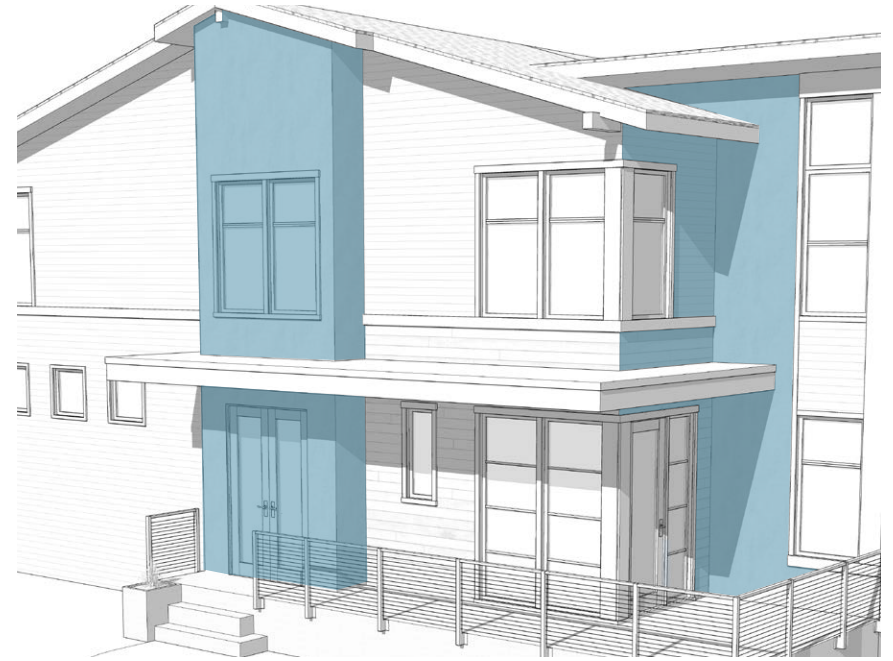

■ Building Materials:

- All homes shall be constructed with a secondary facade material. Example: Bead Board (primary material), brick base (secondary material).
- Cladding dimensions from the front elevation shall be consistent for all elevations

■ Building Projections:

- Projected elements, such as bay windows, shall be integrated with the main mass of the building in terms of materials, textures, proportions, and colors. Alternatively, elements designed to reflect a specific re-use character may be contrasting in color and/or materials.



UNIVERSAL ARCHITECTURAL CRITERIA

■ Front Porches and Covered Entries:

- A covered porch or covered entry compatible with the architectural style of the home shall be required.
- Covered porches (80 square feet or greater) shall be a minimum of eight feet deep.
- Covered entries are mandatory and shall be a minimum of 36 square feet and six feet deep.

■ Decks:

- Decks shall be integral to the architecture of the house through column and railing details.
- Covered decks shall have roof forms consistent with the house.

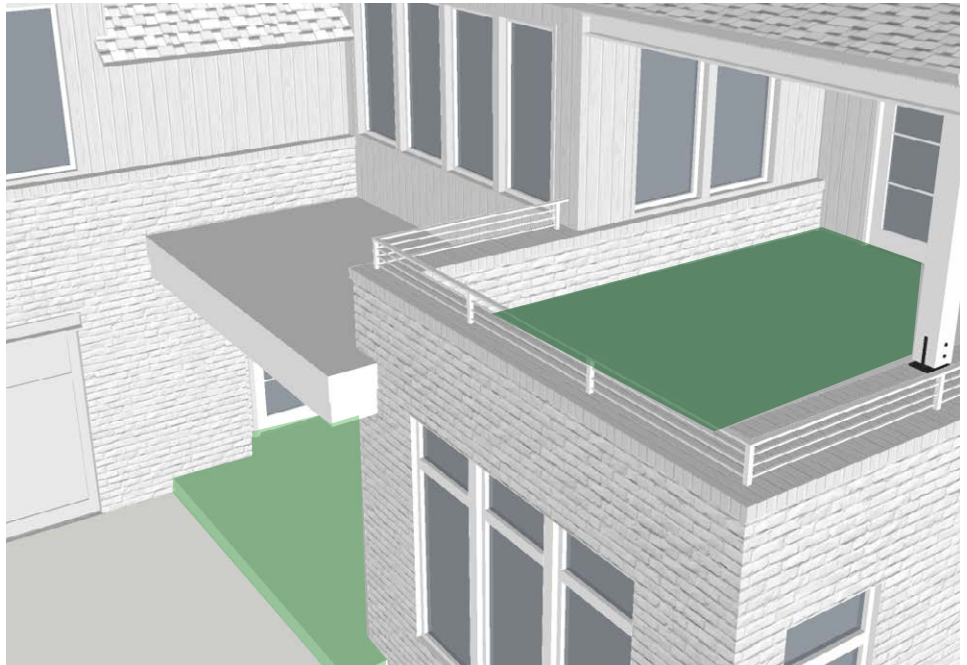

■ Color:

- On any structure, color variety shall relate to changes of materials, such as building base, facade, and roof. This creates a varied palette of colors
- When compatible with the architectural style of the home, window sash, mullions, and trim shall receive accent colors to emphasize details



UNIFIED DIVERSITY

Plan Repetition

A home shall promote unified diversity by being compatible with neighboring houses. A combination of one and two story homes shall be mixed together along the streetscape, creating variety and visual interest. A color or material change does not constitute a change in elevation.

Building footprints and elevations shall be varied based upon the following requirements:

- If the plan is to be repeated with the same front elevation design on either the same side or opposite side of the street, it shall not occur more frequently than every third (3rd) consecutive lot. Thus, where this situation exists, at least two (2) other homes shall occur between the next repeated front elevations. Brick and trim color in this situation shall be different.
- If a plan is to be repeated with a different front elevation design on the same or opposite side of the street, it shall not occur more frequently than every second (2nd) consecutive lot. Thus, where this situation exists, at least one (1) other home shall occur between the next repeated floor plan with a different front elevation design. Brick and trim color in this situation shall be different.

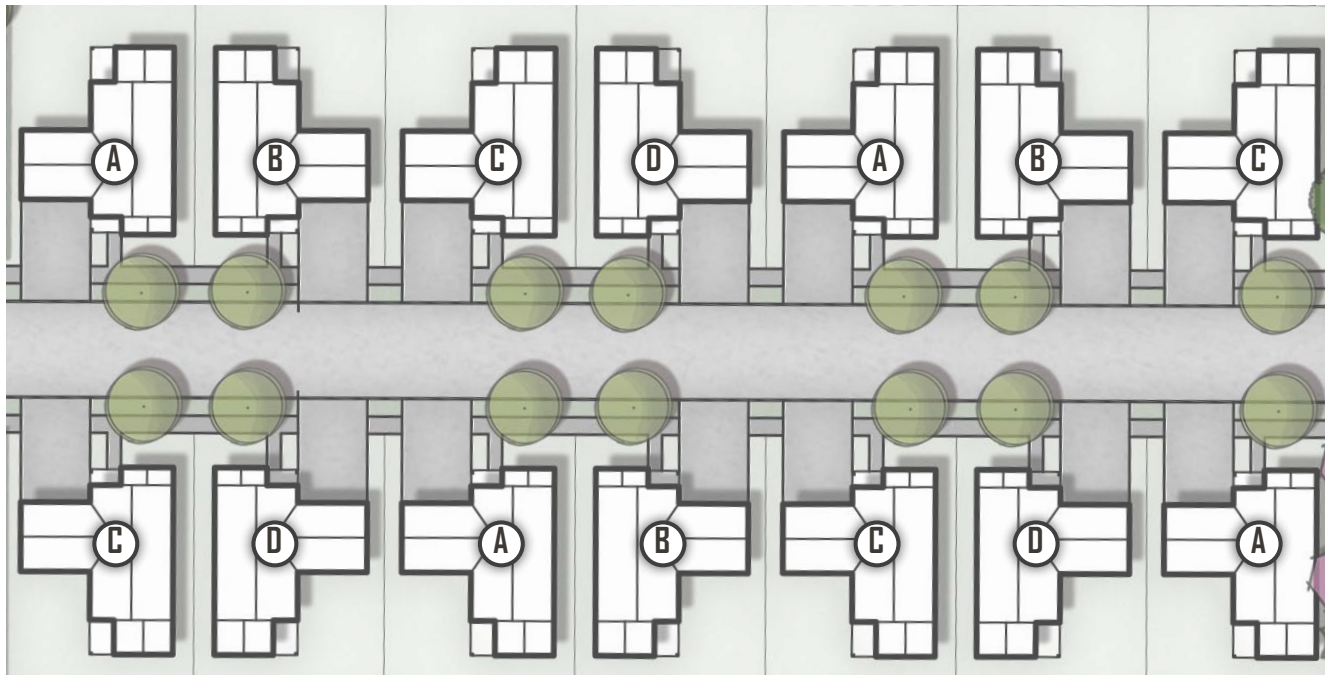



In order to create variety along a street without requiring additional floorplans, use a mix-and-match approach including enhancements and alternative elevation styles.





SITE PLAN AND LOT CRITERIA

BRIDGELAND CENTRAL EASTHAVEN

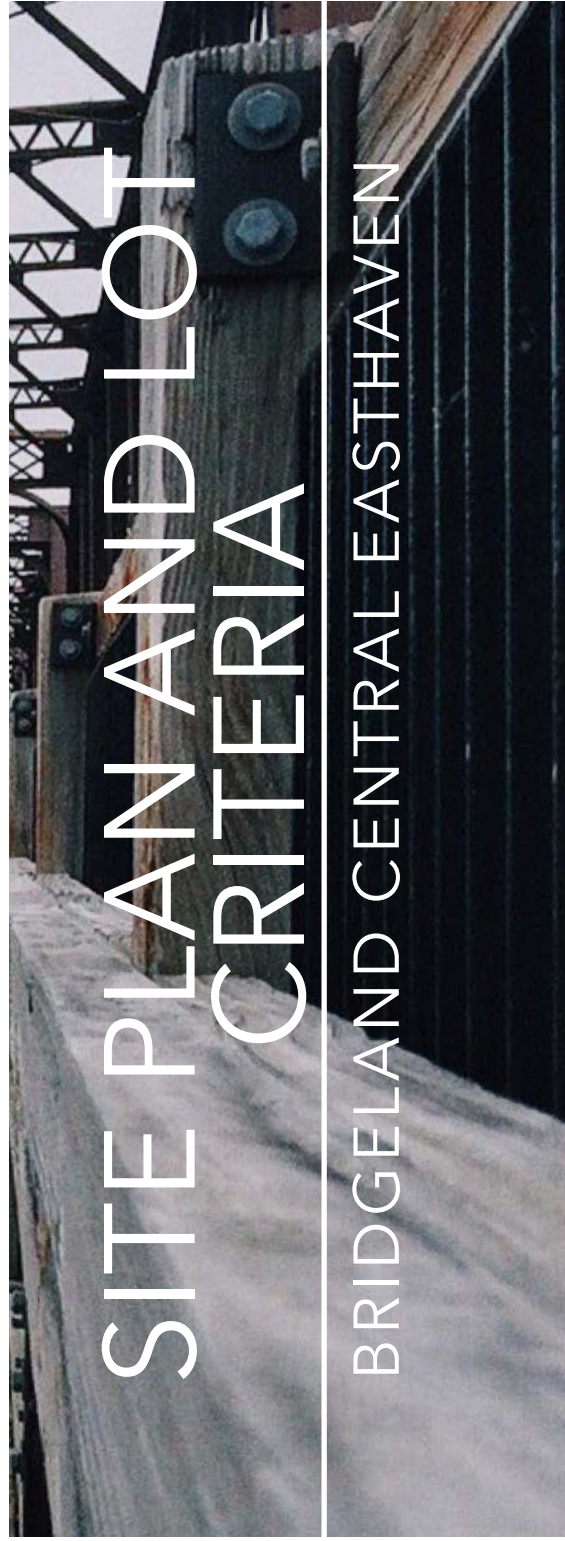

SITE DESIGN INTENT

Bridgeland Central Easthaven is a neighborhood located within the overall Bridgeland Community. Easthaven offers many amenities including a two neighborhood parks and connections to the lake extension corridor. The project site which these guidelines specifically address is in the east portion of Bridgeland Central. The unique “court” style product offering creates easily amenitized private recreational space while maintaining a traditional street scene. This site leverages straight-forward planning and traditional neighborhood design to create an intimate character that links into the overall Bridgeland Central vision.

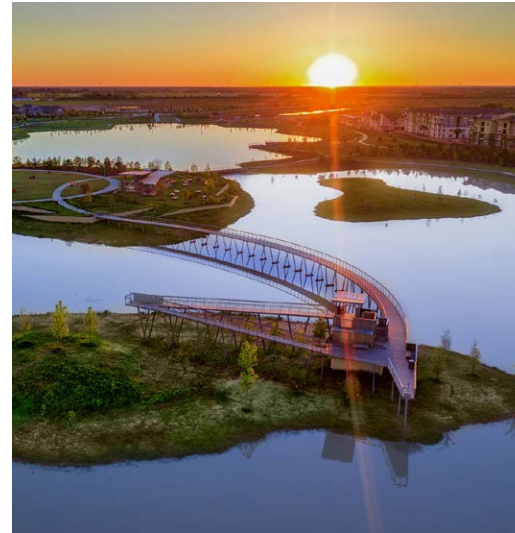

BRIDGELAND MASTER PLAN

III.39



UNIQUE SITE CONDITIONS

P

R

Side and Rear Architecture:

For locations where side or rear architecture will be highly visible from the street or open space, design and aesthetic considerations should be made to ensure consistent appearance throughout the community. In these locations enhanced facade will be required.

R - "required" to meet enhanced side and rear architecture.

P - "preferred" to meet enhanced side architecture requirements

Side Architecture and Open Space:

For locations where side architecture will be adjacent to open space, the interface and aesthetic should be made to ensure privacy but also contribute to the quality of the space. In addition to augmented screening, in these locations enhanced facade and landscape treatments will be required.

!

Visual Terminus:

The street pattern creates visual corridors that guide the sight lines. Certain locations will implicitly become the focal points at the terminus of a street. In these locations enhanced facade and landscape treatments will be required and driveway/garage door locations should be located to the far side of the visual terminus.

Front Loaded Units on Corners:

The extra width in a corner lot creates opportunities to wrap the architecture around the corner. In these locations enhanced facade and landscape treatments will be required.

Linear and Public Open Space:

Where units front or side onto public open space, clear transitions between public open space and private yards should occur. Use of low walls, hedges, steps, decorative front yard fences or grade change are encouraged.

Builders are required to coordinate front access location with the Master Developer and receive approval from the ARC when designing front access walks along public open spaces.

Street Trees:

Each street shall be planted with a specific street tree species to help distinguish the streets within the neighborhood. For street tree specifications, refer to exhibit IV.56.

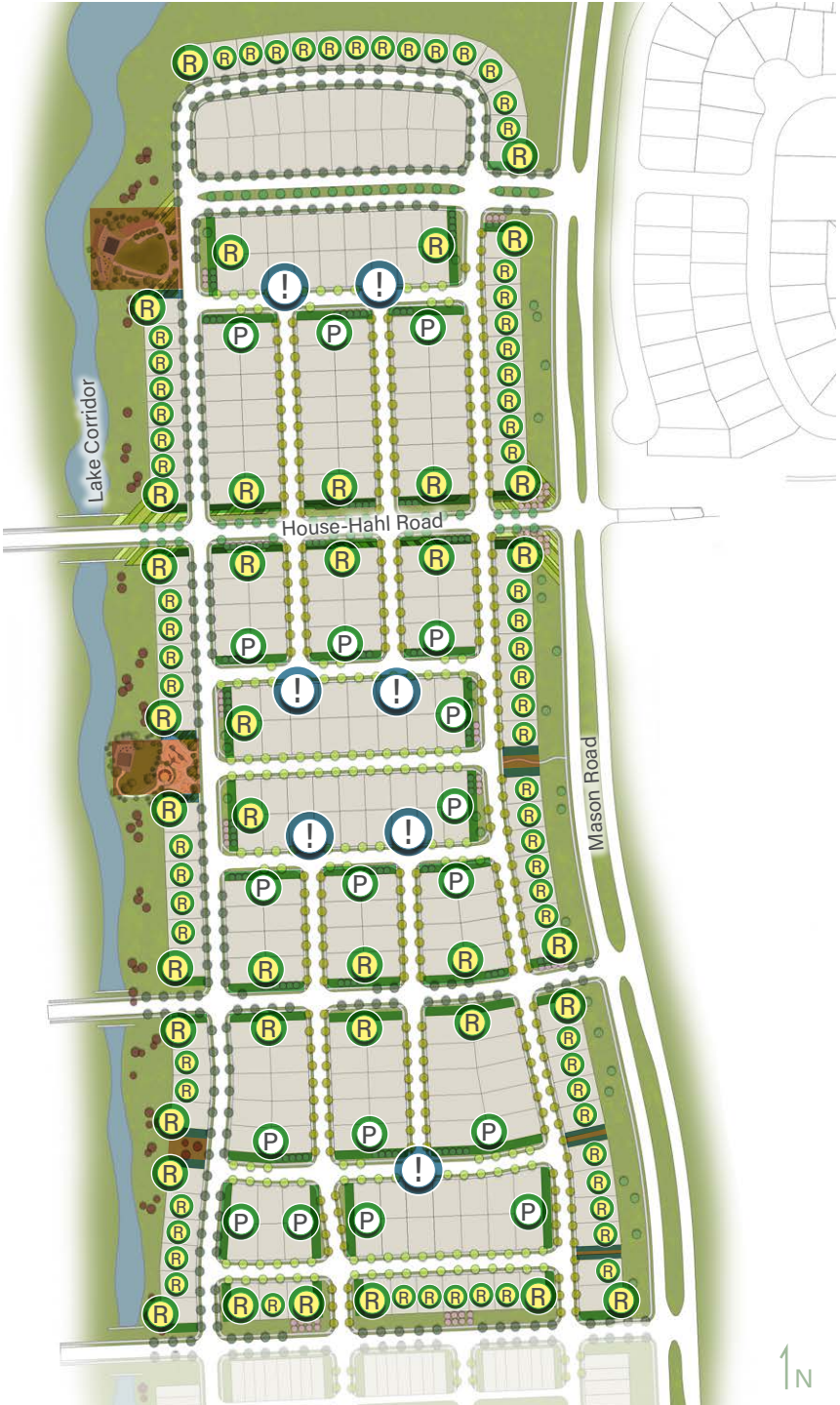

↑ N NTS

LOT REQUIREMENTS 55' + 62' LOTS

Streetscape:

The design intent of Easthaven is to encourage residents to “live to the street.” By requiring larger porches, and minimizing front setbacks, the houses engage the street directly.

Building Orientation:

Building orientation is required to address the primary street with which it is associated. In the case of corner lots, the primary street is that with which the adjacent, similarly-oriented lot addresses.

Paving:

All entry walks and driveways shall be composed of concrete. Driveway paving shall be consistent with front walk (see landscape design criteria for pavement finish requirements).

Utility/Equipment:

In the case that utility meters, A/C compressors, and any other mechanical equipment which cannot be located and/or screened by architecture, landscape elements and fences shall be used to screen such implements from public view and to minimize visual impact. Dry utility meters and equipment shall be located in predetermined areas within rear setback.

Refuse/Storage:

No trash, recycling, compost, wood piles, etc. shall be stored in publicly visible location. Appropriate enclosures, fencing, walls, or landscape screen will be employed to minimize visual impact.

Driveway Tapering:

1. If $\leq 20'$ from Face of Garage Door (FOG) to Back of Curb (BOC) then no taper required at connection point
2. If 20-24'11 from Face of Garage Door (FOG) to Back of Curb (BOC) then taper to $\geq 23'$ at connection point
3. If $\geq 25'$ from Face of Garage Door (FOG) to Back of Curb (BOC) then taper to $\leq 20'$ at connection point

Setbacks

Front

- 10' Setback
- 20' Garage Setback

Rear

- 8' Setback

Dry Utility Easement

- 7' Setback off Rear Lot Line

Passive Side

- 5' minimum

Active Sides (Alt. Suggestion)

- 20' (House/Residence)
- 5' (Garage)

Minimum Porch Dimensions

- 8' Depth
- 8' Width

- Lot Dimensions- 55' x 75' and 62' x 75'
- Mandatory Open Space/ Court- 20' x 20'
- Garage to be 20' x 20' min. (or 2-5' deeper to accommodate 2 garage doors)
- Garages must have door or second garage that opens to rear Open Space
- Driveways must be 18' wide

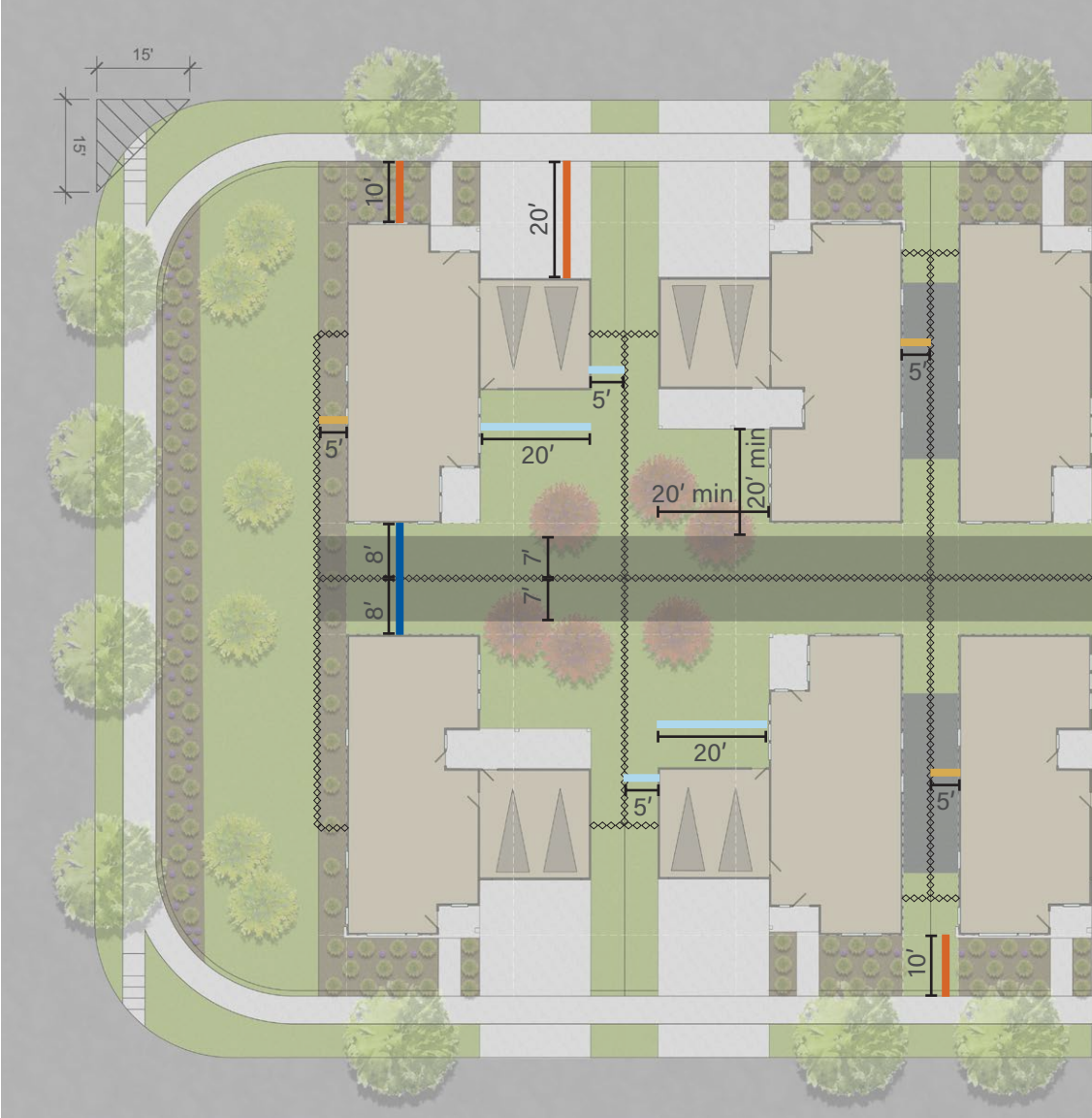

BACKYARD ORIENTATION

Lot Greenspace

Yards shall be oriented as outlined below. This will ensure the integrity of the intended green spaces on individual lots. Changing backyard location is prohibited.

- 4 Yards Facing Towards Each Other.
- 2 Yards Facing Towards Each Other.
- 1 Yard Facing Towards Community Open Space.



STREET SECTIONS

Streetscape:

Street sections include two 5' sidewalks and two 7' tree lawns. One street tree shall be planted per lot, spaced evenly between driveway and far side property line (refer to exhibit IV.56).

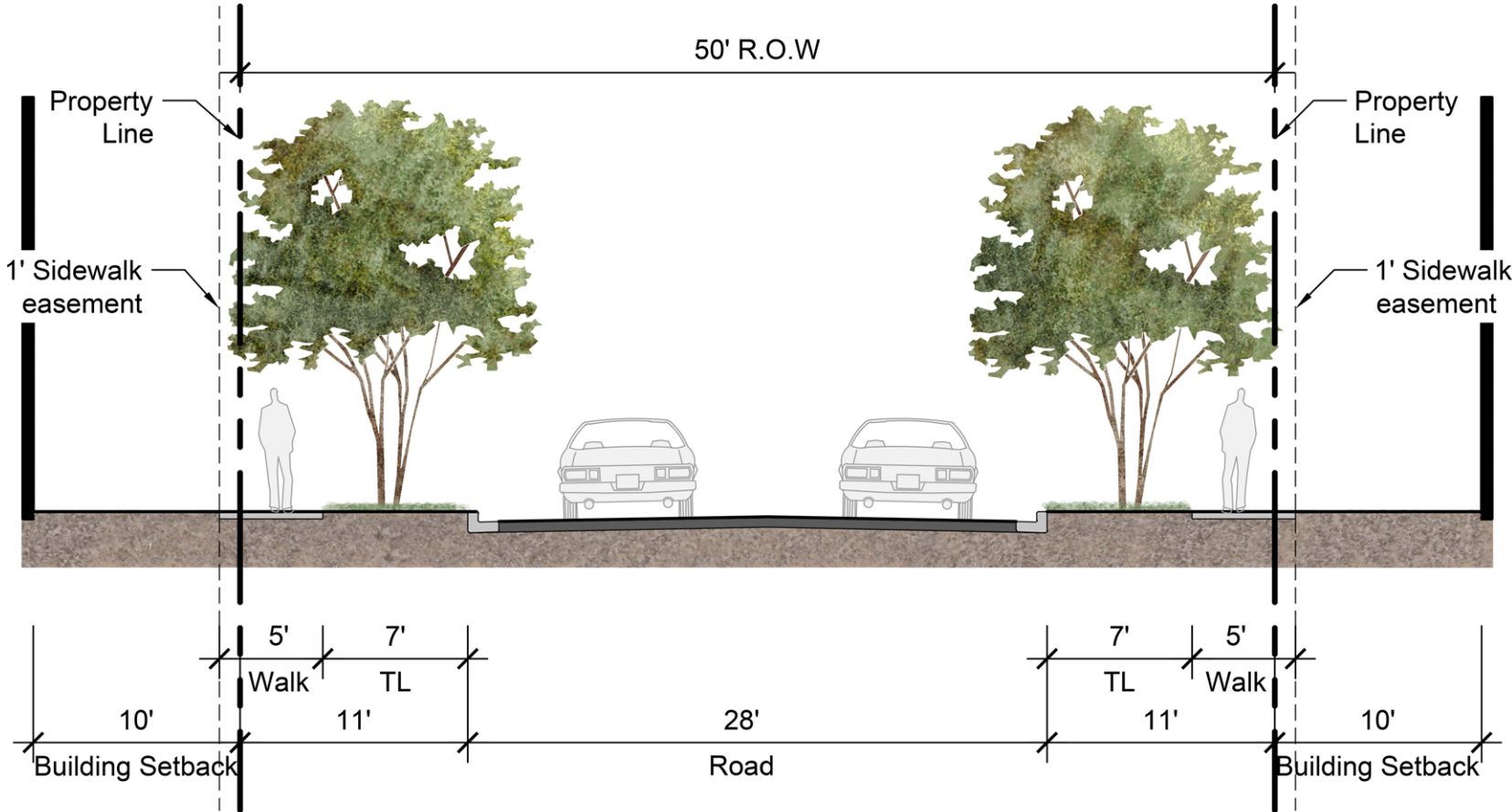





LANDSCAPE DESIGN CRITERIA

BRIDGELAND CENTRAL EASTHAVEN

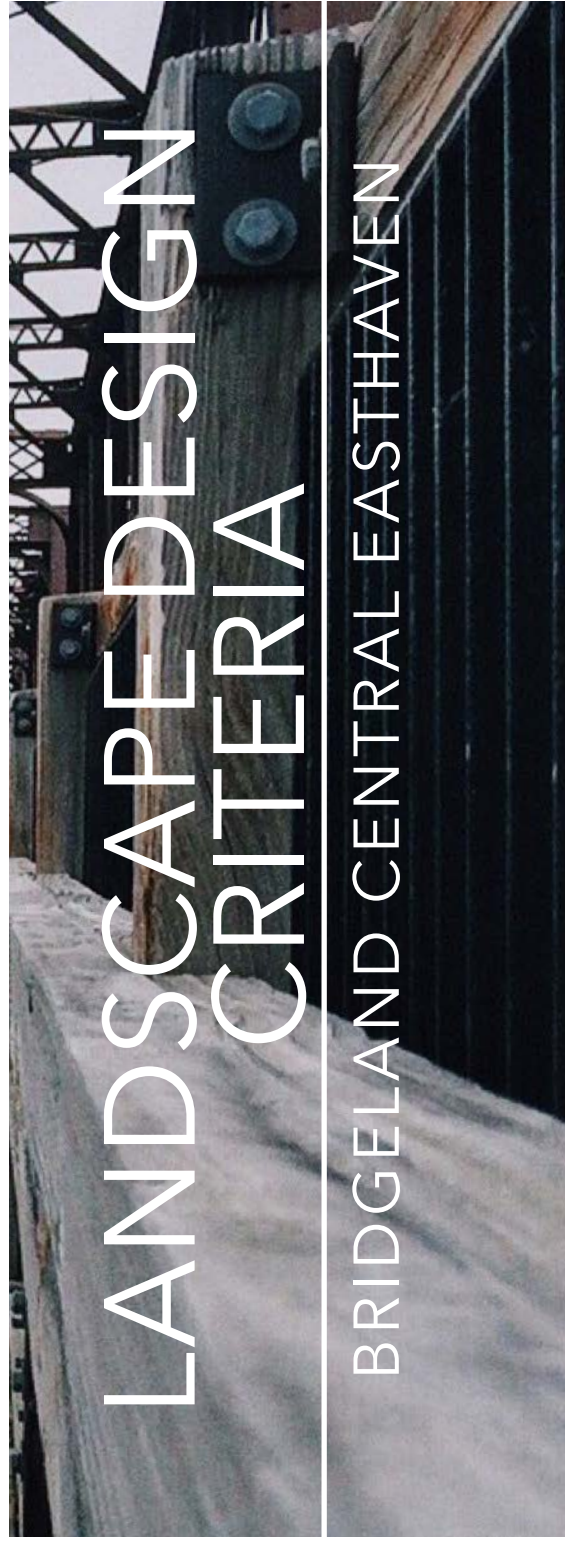

OVERALL INTENT

Bridgeland Central is characterized by a network of linear parks and open space connections. The parks are further connected to the Bridgeland Central - Easthaven open space network through a series of trails, linear parks, and paseos.

Individual landscapes within Easthaven are expected to support the overall open space concept. This can be accomplished through several avenues such as plant selection, material selection, planting bed location and design, and integration between public and private landscapes. In the following section of the Design Guidelines for Bridgeland Central - Easthaven, strategies and requirements are discussed to enumerate the intended landscape approach. Adherence to these Guidelines is the first step toward creating a cohesive landscape character throughout Easthaven.

In addition to minimum landscape requirements, these design guidelines provide optional landscape upgrade programs that may be used instead of meeting minimum landscape requirements. In the case of using a landscape upgrade in lieu of meeting minimum requirements, builders, homeowners, architecture and their respective agents shall use pre-approved designs or get approval from the ARC.

The purpose of these landscape guidelines is to support builders, homeowners, architects and their respective agents and representatives in producing landscapes that achieve the desired results while allowing flexibility and creativity. Any variances from these guidelines shall be a subject to approval by the ARC.

OVERALL INTENT

IV.49



OVERALL INTENT

Plant Selection

The landscape selection should bring together a cohesive community identity. It should reflect the design of the architecture. A limited variety of plants, selected for seasonal interest and textural contrast is ideal for creating a cohesive aesthetic throughout the community.

Massing

Along with plant selection, massing strategies offer another avenue to creating a unifying affect through the landscape. While it is not required to match plant species between lots and public areas, simulating similar massing and organizational patterns will foster a cohesive community character. Typical massing may incorporate swathes of species with specimen plantings to highlight key landscape areas.

Grading

Grading design for Easthaven should feel natural and flowing. Rigid, highly engineered topography shall be discouraged. When using berms, undulate the ridgeline to create visual interest and avoid straight barriers. If employing site retaining walls, grade changes shall be less than 30 inches from top of wall to base of wall. Where possible, builders should opt for naturalized grading solutions instead of site walls. Aesthetic grading strategies shall comply with all applicable building codes.

OVERALL INTENT

IV.51



Choose a limited variety of plants that create dynamic contrast. Use high-impact plantings to create visual interest and subtle background plants to highlight architectural and site elements



Formal groupings of plants create a sense of order while contrasting textures and colors create visual interest



Simple background colors should be used to highlight the unique form and color of accent plant materials.

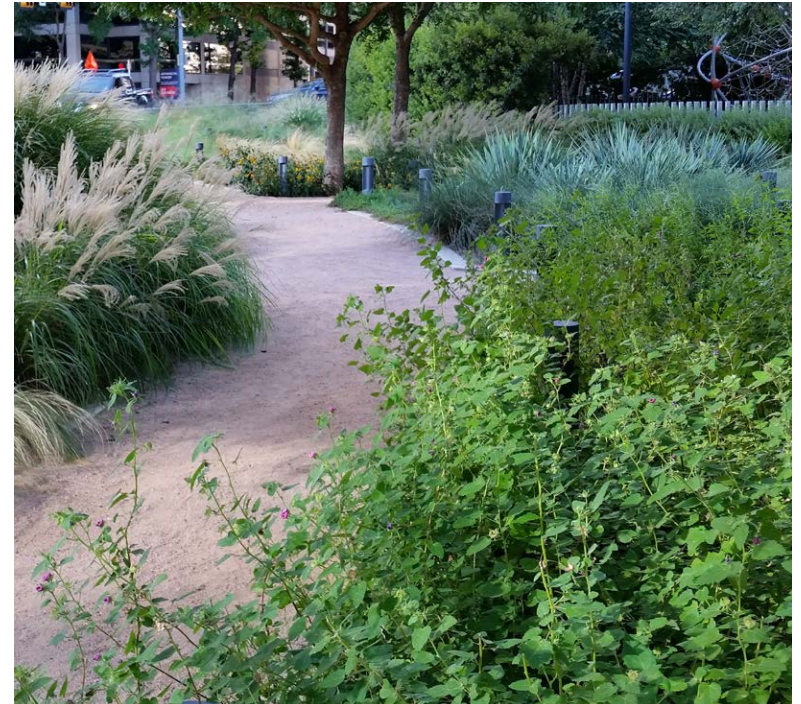
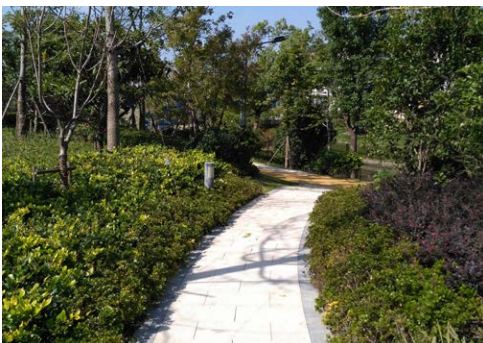

SITE IMPROVEMENTS

All site improvements shall be reflective of the contextual architectural styles and landscape elements. Features that may be seen by the public or from the primary street must be respectful of the aesthetic character of the associated house. Elements that may be considered eyesores shall be screened to appropriately hide them from public view. In the case that screening is not possible, such elements shall be subject to review by the ARC.

Reasonable effort shall be made to match materials and treatments of all site improvements to the architectural style of the house and to act as an extension of the architecture.

Utility Screening

Hedges, fences and low enclosures are required for the purpose of screening miscellaneous equipment, trash receptacles and other functional equipment that may be deemed an eyesore. Efforts shall be made to locate such equipment in areas not visible from adjacent streets. Equipment to be screened by a minimum of a three (3) foot tall shrub or installed screening shall be half the height of the unit to be screened, whichever is greater.

Other elements such as play structures, pool, pergolas, arbors and trampolines shall be subject to approval by the ARC.

SITE IMPROVEMENTS

IV.53

Front Walk Standards:

- Minimum width: 5'-0"
- Must meet public sidewalk at right angle
- Concrete shall have a broom finish (must be consistent throughout lot).

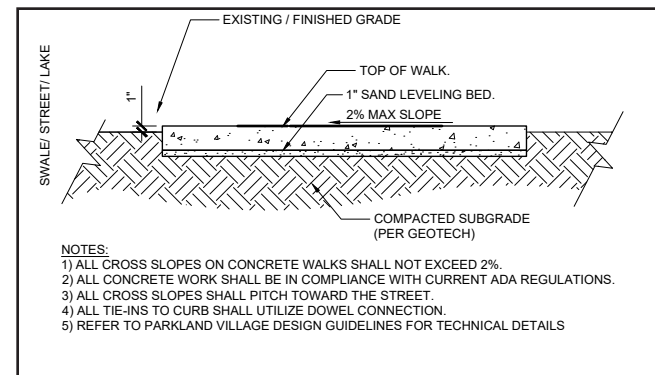
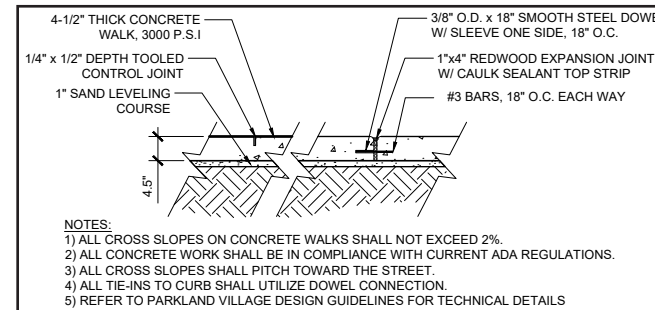
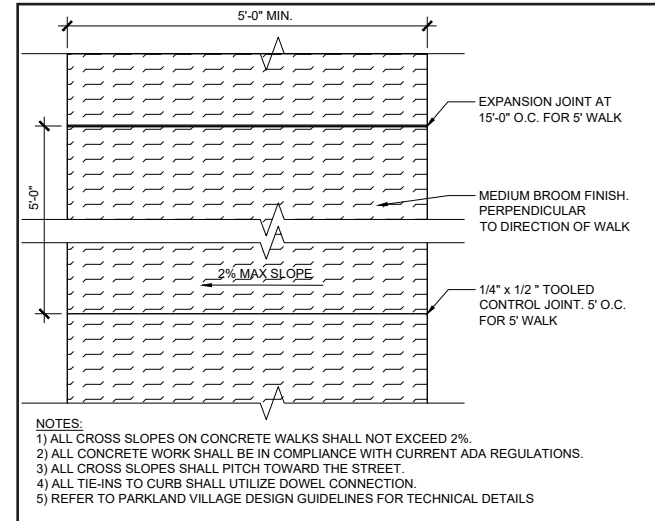

Decks + Patios



Construct decks of similar materials and colors as that of the architecture



Cap garden walls with concrete coping, cut stone, or brick masonry



Integrate terraces and low garden patio walls with the house, composed of similar materials



Design decks and patios to be a natural extension of the house.

Design Requirements

Paver Product: CityStone by Keystone Hardscapes
 Size: 12x24, 60mm (2.36") thick
 Color: Charcoal

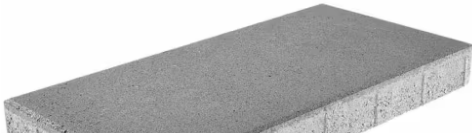

Design Intent:

Step pavers are intended to provide access for the front entry of homes. They are to be used only in the front of homes without open space.

(3) 12x24 step pavers, typ.
 Pavers are to be spaced with gaps as shown – 3 pavers only per 5'-6" wide area. Turf grass is to continue between pavers. Centerline of pavers shall align with centerline of walk to unit

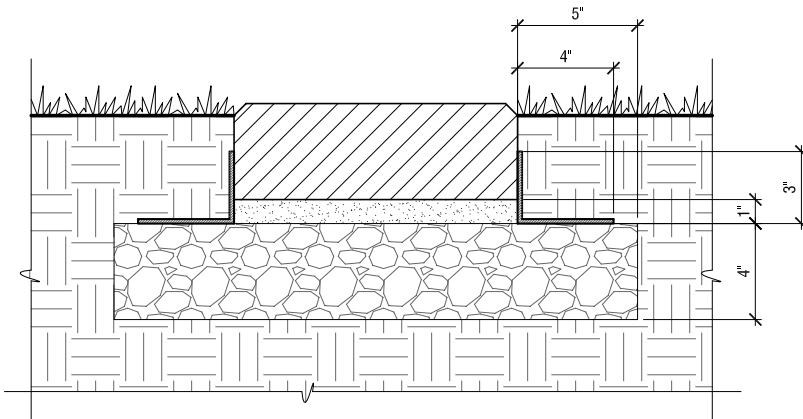

General Notes

1. Only one set of step pavers are allowed per lot.
2. Pavers are to be set flushed with adjacent grades.
3. Pavers are to be set directly on compacted subbase. Irrigation line will continue run under pavers.

Step Paver Plan

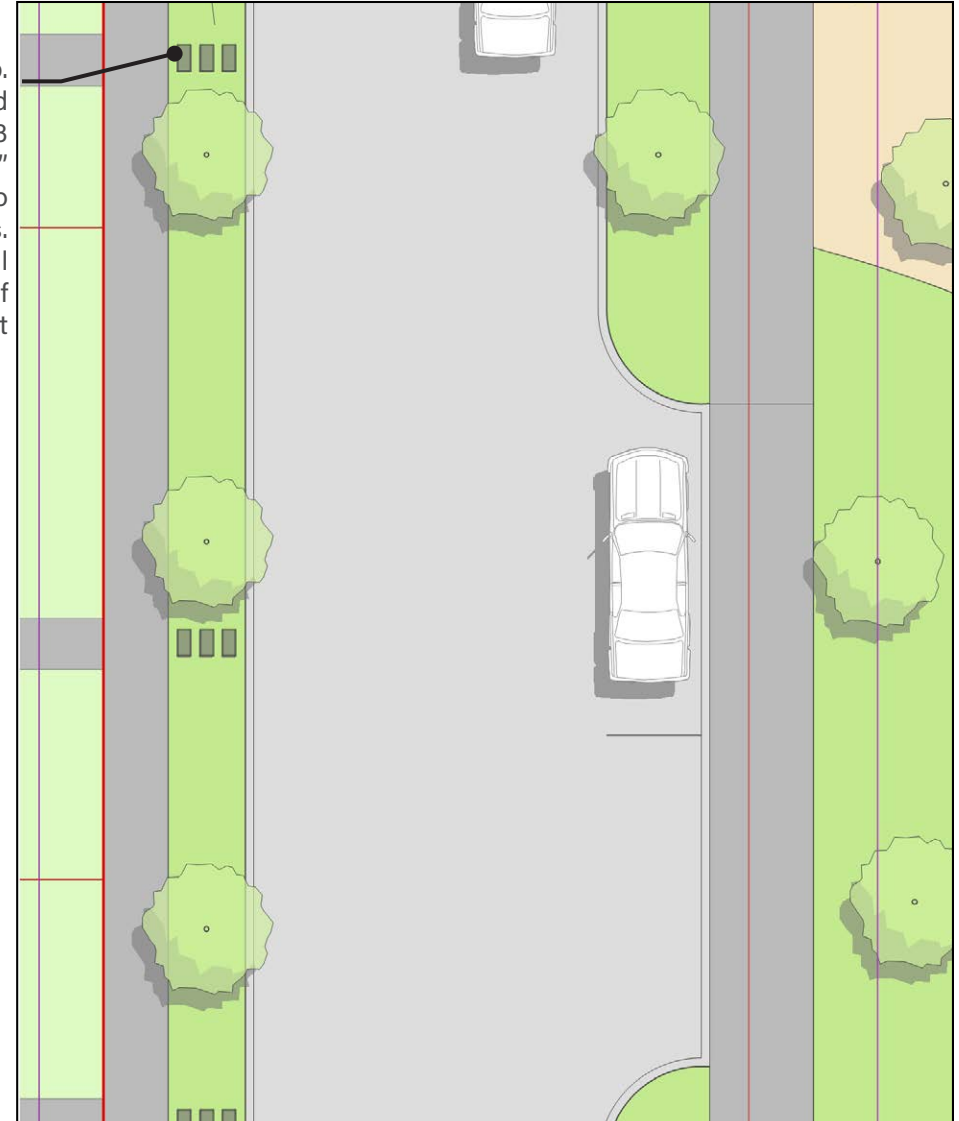

LANDSCAPE REQUIREMENTS

Tree Standards Diagram

Area A

- LIVE OAK (*Quercus virginiana*)

Area B

- SHUMARD OAK (*Quercus shumardii*)

Developer Responsible

Builder Responsible

Area C

- DRAKE ELM (*Ulmus parvifolia* 'Drake')

Area D

- NATCHEZ CRAPE MYRTLE (*Lagerstroemia indica* x *fauriei* 'Natchez')
- ARAPAHO CRAPE MYRTLE (*Lagerstroemia* 'Arapaho')
- EAGLESTON HOLLY (*Ilex* x *attenuata* 'Eagleston')
- LITTLE GEM MAGNOLIA (*Magnolia grandiflora* 'Little Gem')

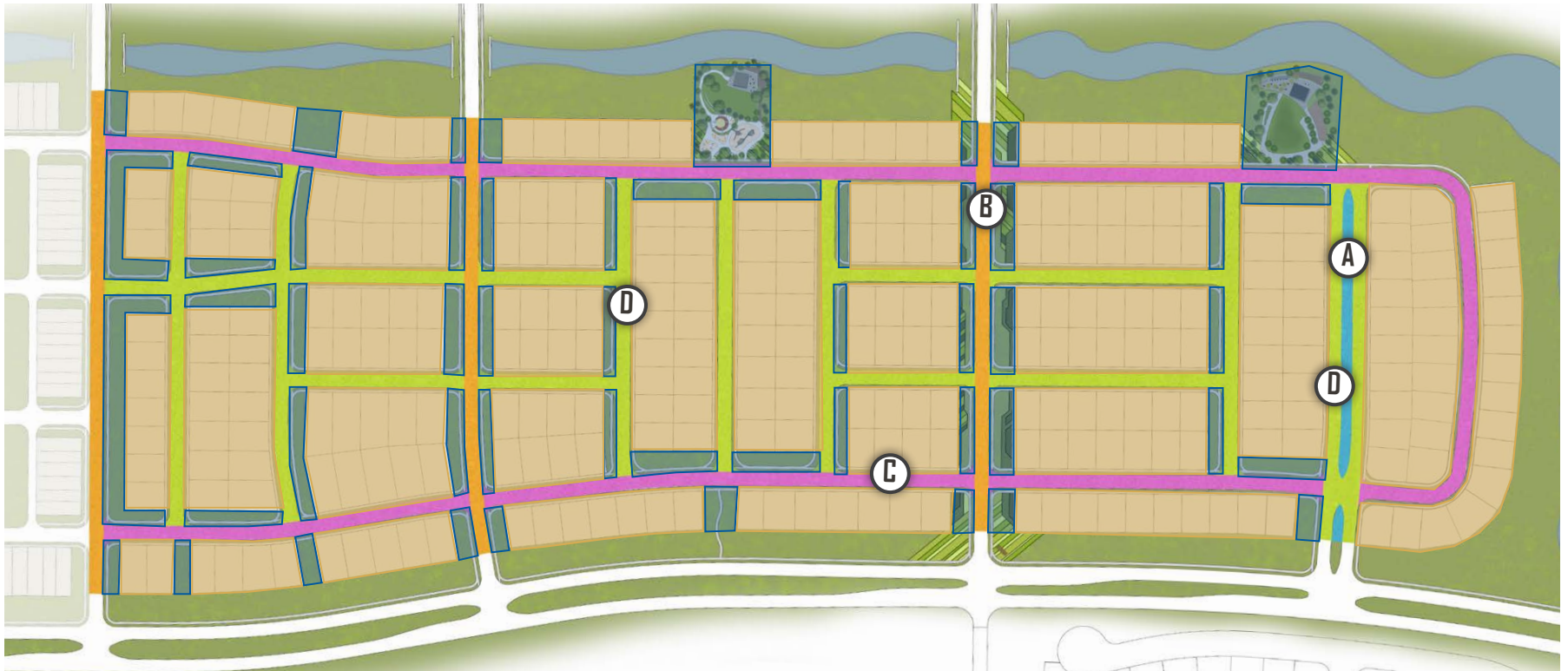

Tree Standards Diagram

Builder Responsible

The Builder is responsible for tree placement in front of home. That includes areas that extend in to the Right-of-Way.

Tree Lawn (Street Trees)

Trees within tree lawn should be selected based on Exhibit IV.56.

Tree shall be centered within the tree lawn between edge of driveway and property line.

In order to create variety along a street, builders are required to use a mix-and-match approach for tree species on areas that have multiple street tree options.

The same species cannot occur along the same side of the street within three (3) consecutive lots on areas that have multiple street tree options.

Developer Responsible

The Developer is responsible for tree placement in designated open space and park areas.

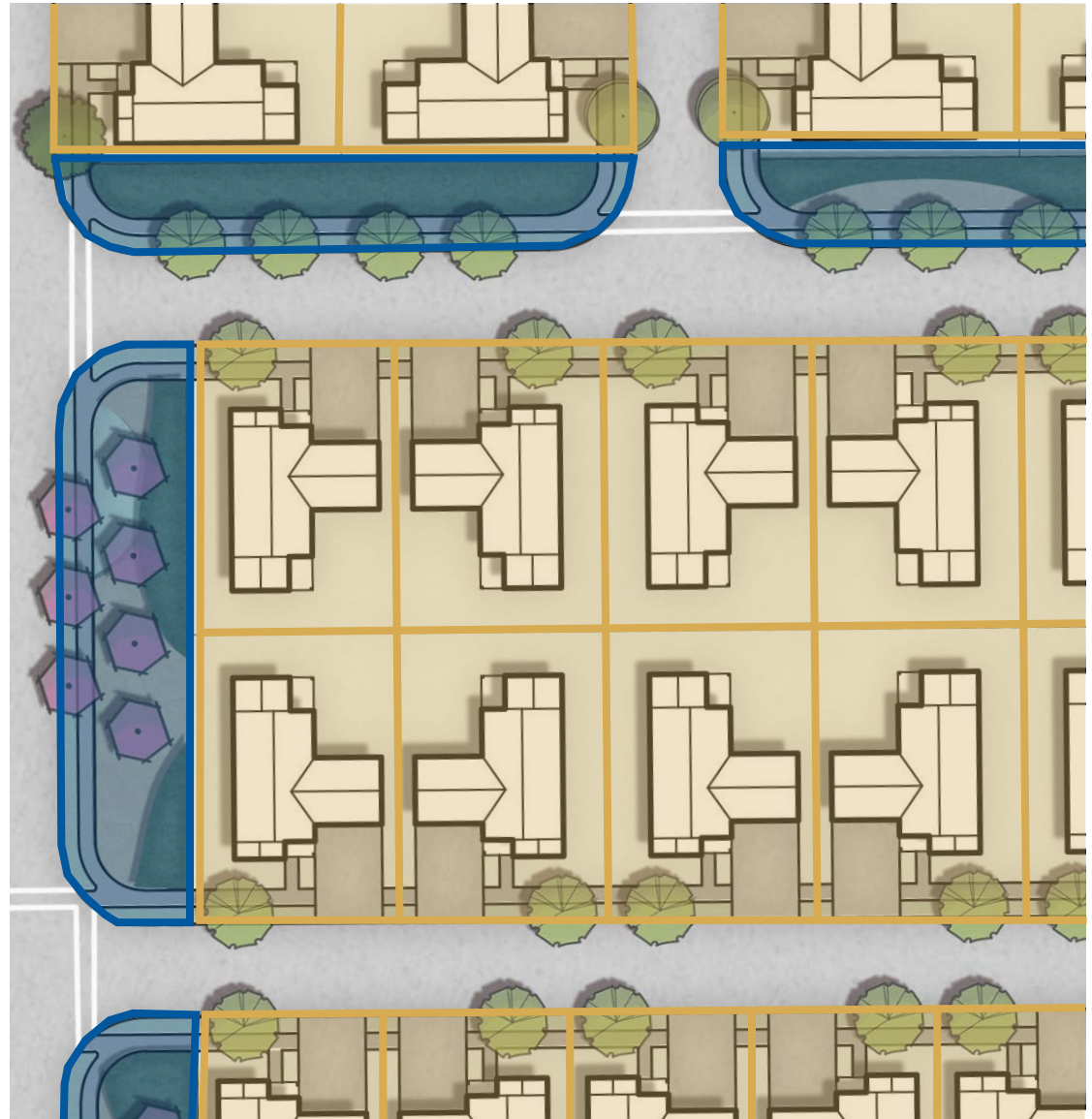

LANDSCAPE REQUIREMENTS 55' + 62' LOTS

Front Yards

Shrub beds and other landscape improvements are preferred over turf/sod. Shrub beds shall incorporate larger shrubs closer to the building, gradually stepping down as the landscape approaches the street.

Rear Yard

Rear yard landscaping should be planted and maintained to provide shade and usable space. Landscape character should be consistent throughout the lot. Additionally, sustainable practices are encouraged in the rear yards. These practices may include but are not limited to: fruit trees, vegetable gardens, mosquito repellent plants, native plants, minimized lawn area, rain water collection for irrigation, rain gardens, and composting.

Enhanced Conditions

For lots identified in the Site Plan + Lot Criteria Section of these design guidelines as "enhanced," additional landscape requirements shall be required. Enhanced condition lots should be heavily planted to increase privacy and aesthetic value.

Planting Details

Shrub beds may include any of the following: Shrubs, Screening Plantings, Perennials, Ornamental Grasses, Vines, and Ground Covers.

The planting shall be responsive to the architecture (provide a "grounding" effect) and incorporate a reasonable variety of types and species of plants.

Notes:

1. Reference Landscape Requirements and Approved Planting List
2. Full coverage irrigation required in all planting and sod areas.
3. Sod shall be Celebration Bermuda
4. Shrub bed coverage to require 2"-3" of hardwood mulch
5. Planting shall not impede drainage
6. Shrub bed coverage to consist of min. 50% evergreen planting, 20% ornamental grass planting, & 30% additional planting
7. Tree requirements may be waived by the ARC upon conflicting location of street trees.

Requirements Per Building

LANDSCAPE REQUIREMENTS

IV.59

Tree Lawn (Street Trees)

- 1 Shade Tree (see exhibit IV.56)

Front Yard

- Shrubs Beds (80%)
- Turf (20%)

Rear Yard

- Ornamental Trees (1 minimum)
- Shrubs Beds (0% min. coverage)
- Turf (100% maximum coverage)

Passive Side

- Black Star Gravel*

Enhanced Conditions

The following requirements are applied in addition to the above requirements. Each occurrence of an enhanced condition compounds upon existing requirements. If space or off-lot plantings create conflicts, requirements may be waived with approval from the ARC.

Corner-Side + Open Space Lots

- Shrubs Beds (100%) ; unless behind fence and within private yard.

Visual Terminus

- Ornamental Trees (+1 minimum)**

Builder Responsible

Developer Responsible

*Exceptions to requirements may be granted by ARC

**As space allows. If there are conflicts with street trees, the street trees take priority and additional tree requirement may be waived

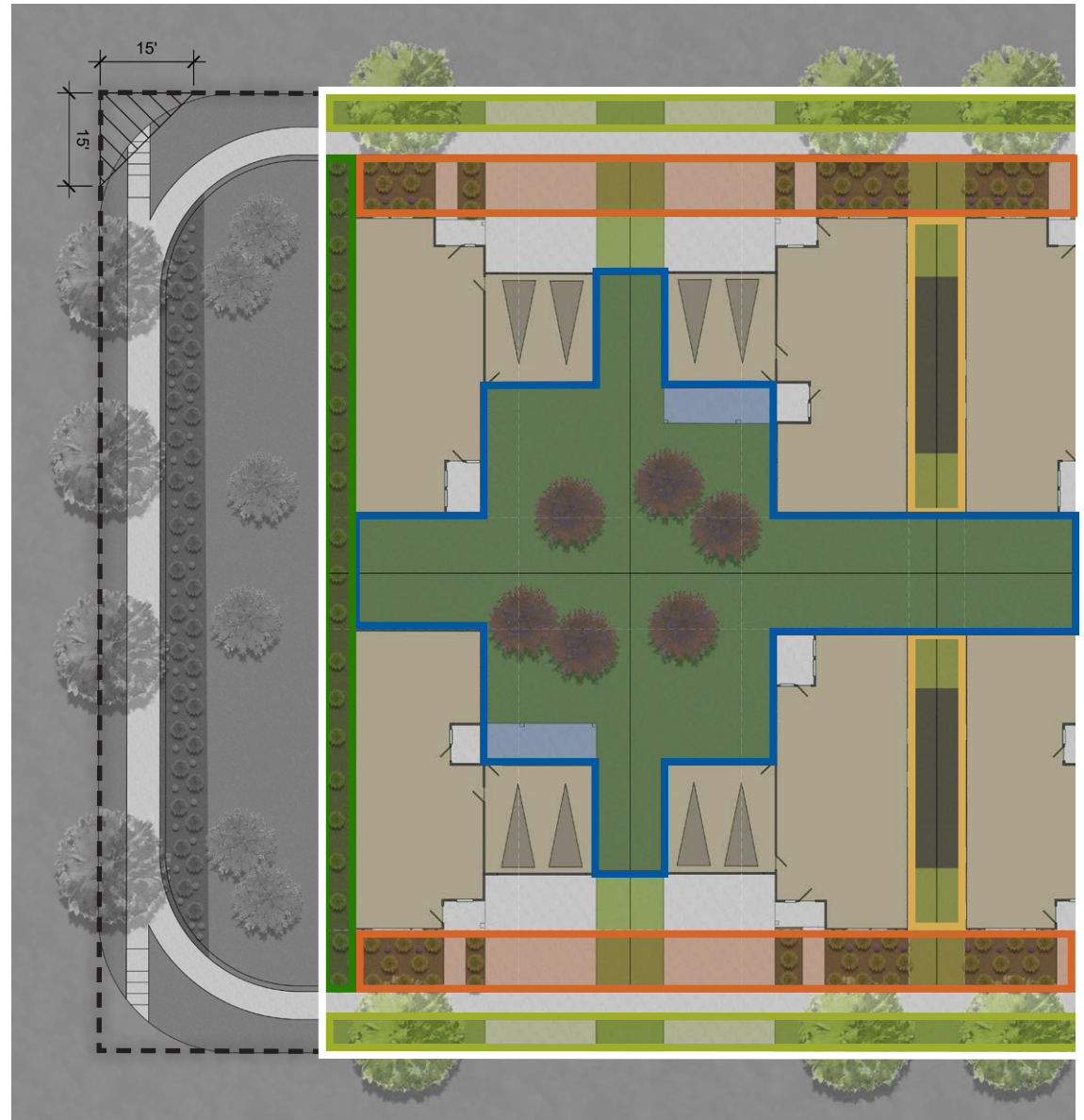

LANDSCAPE UPGRADES

To help create a more dynamic neighborhood, landscape upgrades may be offered in lieu of meeting the minimum landscape standards. All landscape upgrade design are subject to ARC approval. Included are some themes to consider when developing custom landscape upgrades. These designs are based on generic footprints and need to be customized to respond to specific architecture and layouts.



Traditional

The traditional style landscape includes a greater proportion of shrub beds and enhanced plantings to create a sense of enclosure while preserving usable lawn space.



Garden Style

This style draws inspiration from formal gardens with dedicated planting beds, formal design, a central focal point, and at least one vertical design element (i.e. a pergola or trellis)



Pool

Utilizing a lap pool and tanning deck creates a spa-like atmosphere within the courtyard garden in this style. For this style to be successful, the pool is integrated with the surrounding landscape and other amenities are included to provide shade and entertainment opportunities.



Entertainment Focus

This garden is designed for the entertainment-minded. With outdoor seating, a cooking area, optional fire or water feature, and shade structures, this garden acts as an extension of the interior and provides an outdoor place to entertain and relax.

FENCING + GATES

- Steel Tube Fence —
- Horizontal Wood Fence —
- 6' Brick Thin Wall —

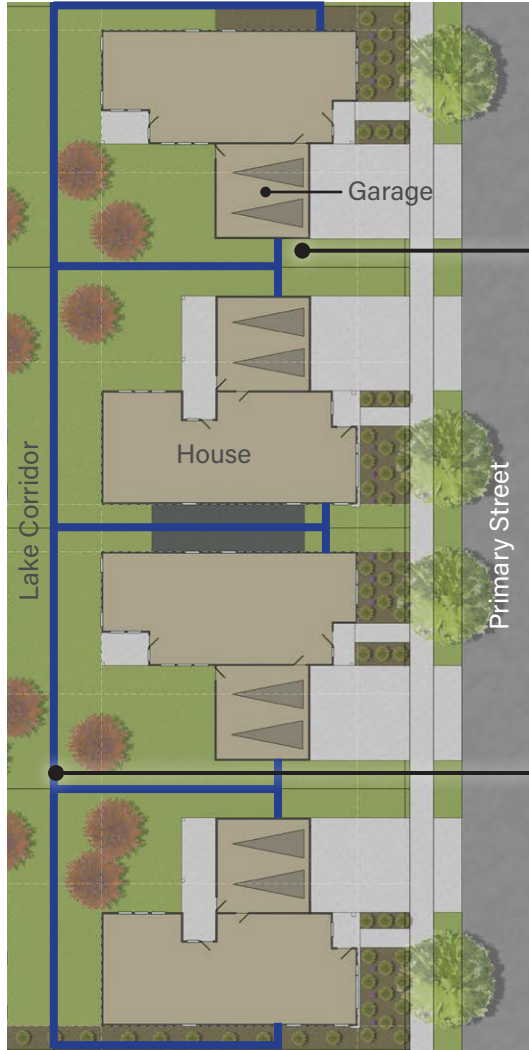

Minimum 5' offset from front facade. Fences between lots shall not align with front Facades. If the porch wraps, the fence shall be behind furthest extent of porch wrap.

Fences shall coincide with property line at rear and side conditions.

Note: See Fence + Gate details at end of this chapter

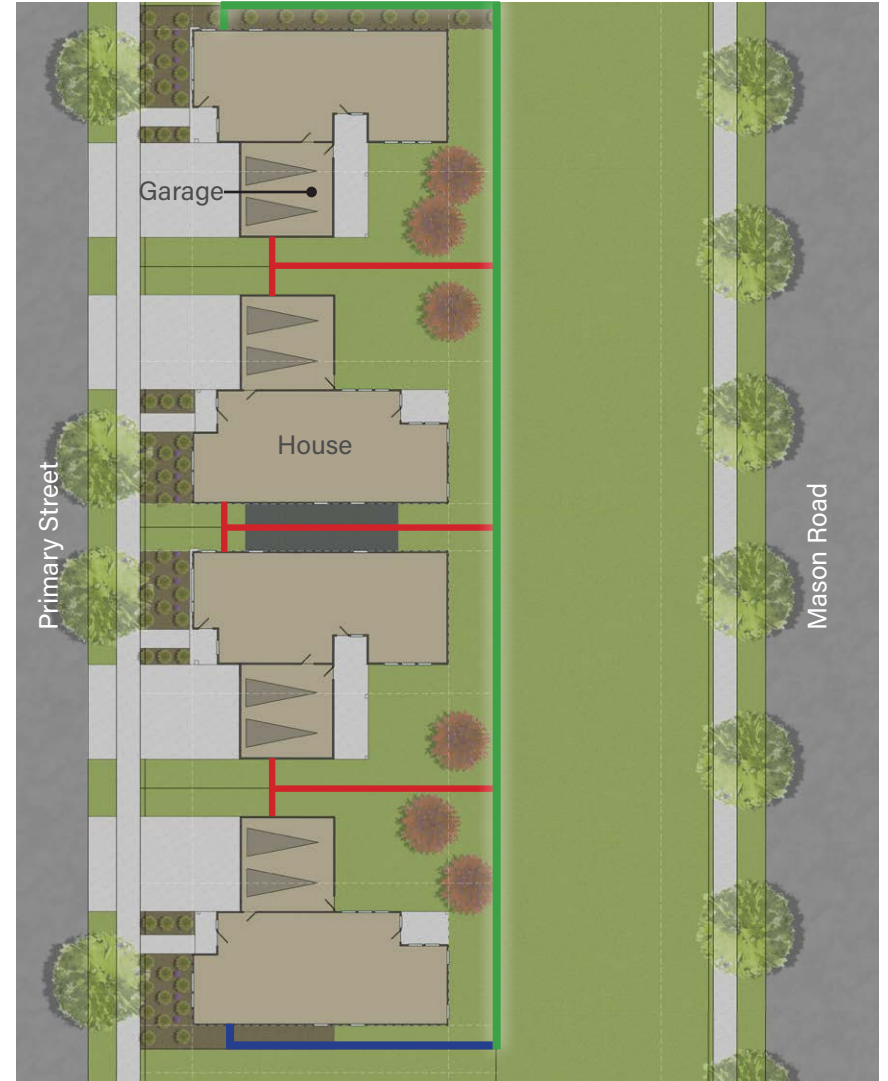

FENCING + GATES

Steel Tube Fence —

Horizontal Wood Fence —

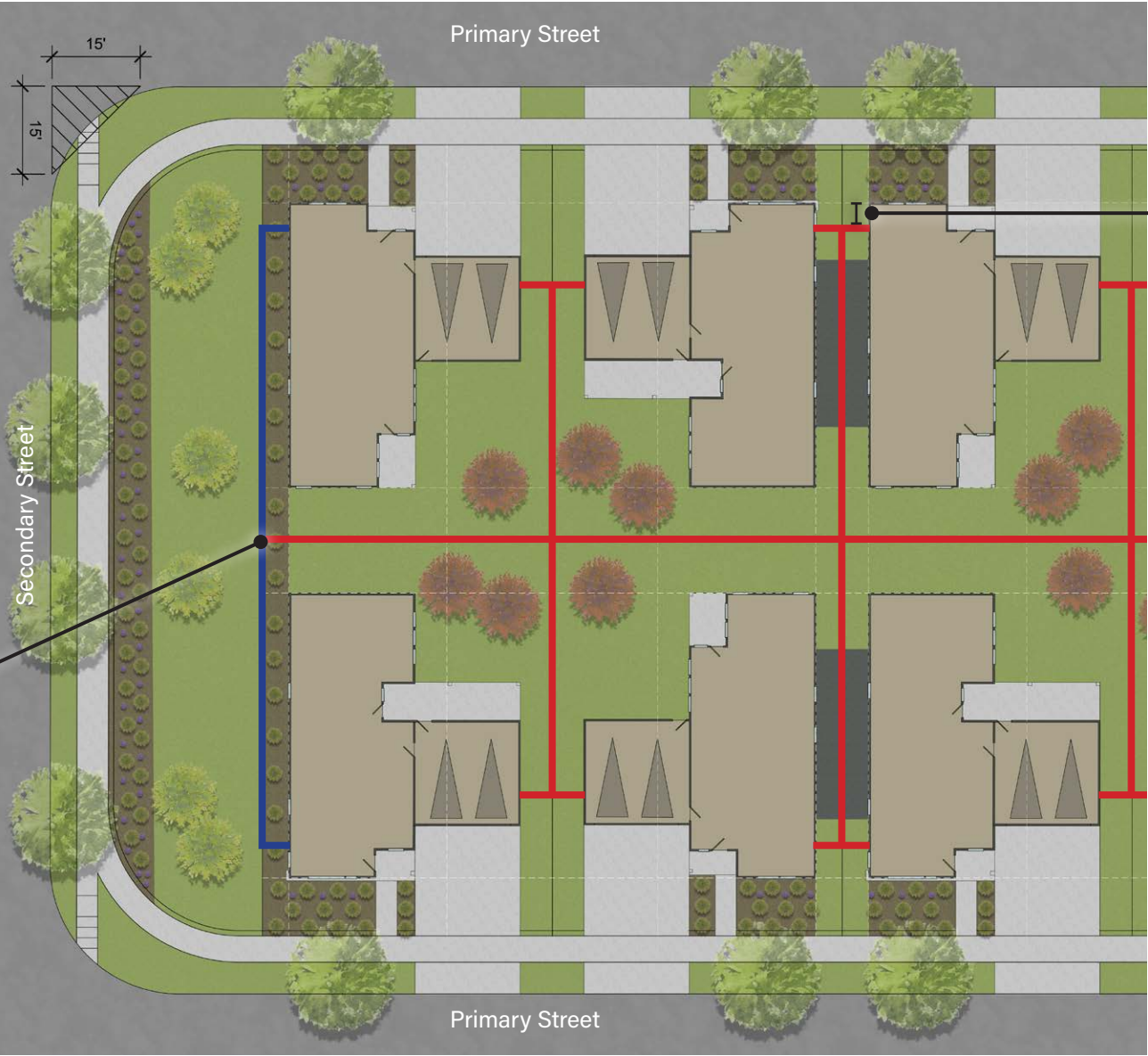

Minimum 5' offset from front facade. Fences between lots shall not align with front Facades. If the porch wraps, the fence shall be behind furthest extent of porch wrap.

Fences shall coincide with property line at rear and side conditions.

*Fences may be excluded if all adjacent property owners agree; however, no permanent improvements may straddle property lines or encroach utility easements.

Note: See Fence + Gate details at end of this chapter

FENCING + GATES

Gate Location

Gates, as access to the rear yard, are essential for maintenance and livability; however, placement of gates shall be restricted in the following conditions:

- No gates shall be located on the secondary street in a corner condition
- Gates shall not allow access between lots unless all adjacent owners consent
- Gates shall not straddle property lines
- If access may be accommodated through the garage, gates may be excluded
- Additional gates may be used to provide access to utilities with approval from the ARC

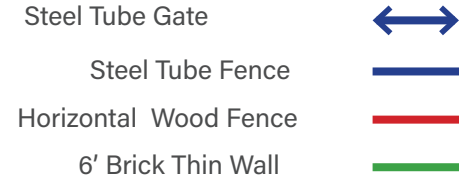

Design Intent

All gates shall be of the same material as the adjoining fence(s). Units with steel tube fences may have access gates at the rear of the lot. Units with 6' Brick Thin Walls shall have access gates on the sides of the unit.

One gate access may be provided per lot facing the primary street. Additional gates may be provided on the passive side condition with approval from the ARC.

Units backing to the Lake Corridor may have up to one gate access.

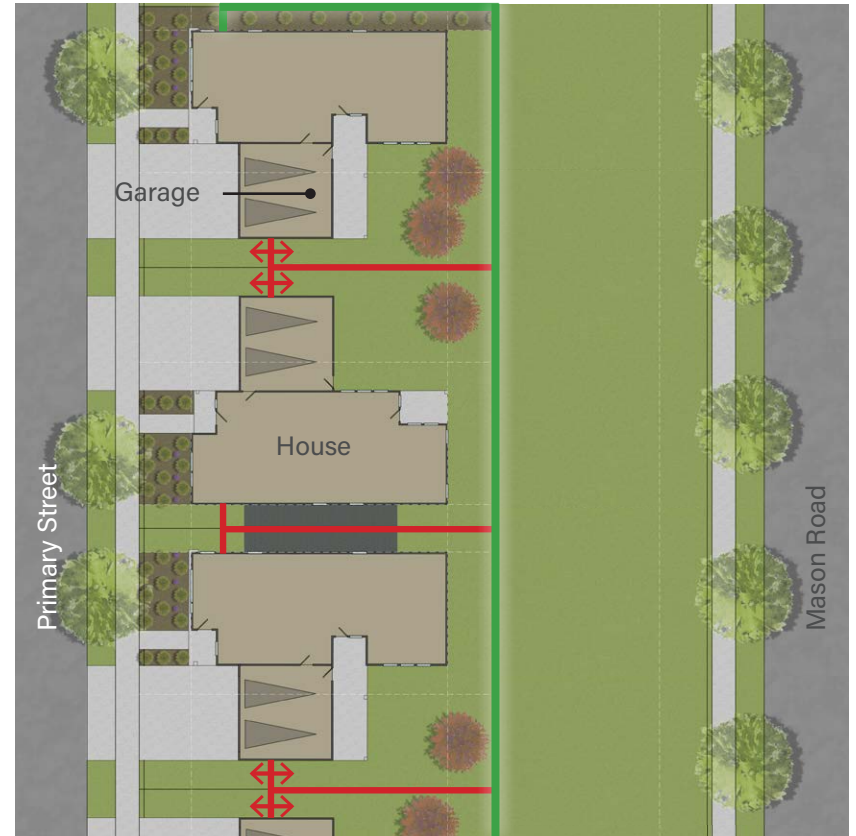
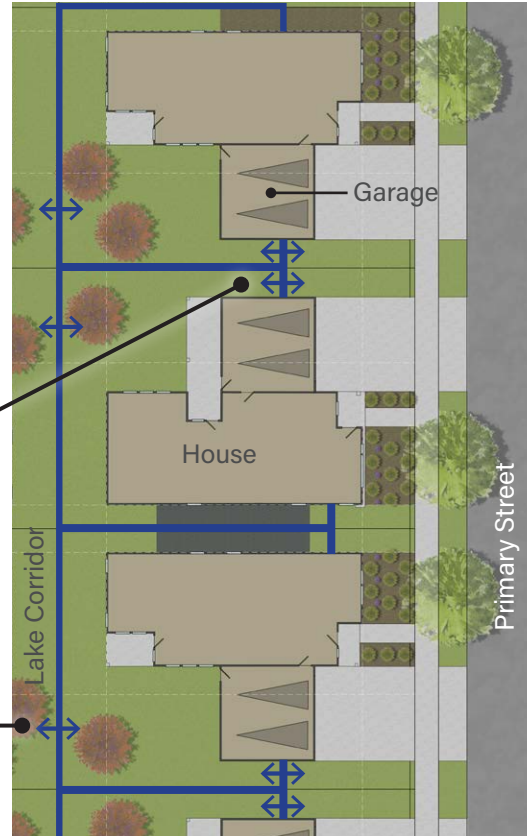

Note: See Fence + Gate details at end of this chapter

FENCING + GATES

Steel Tube Fence —

Horizontal Wood Fence —

Wood Gate ↔

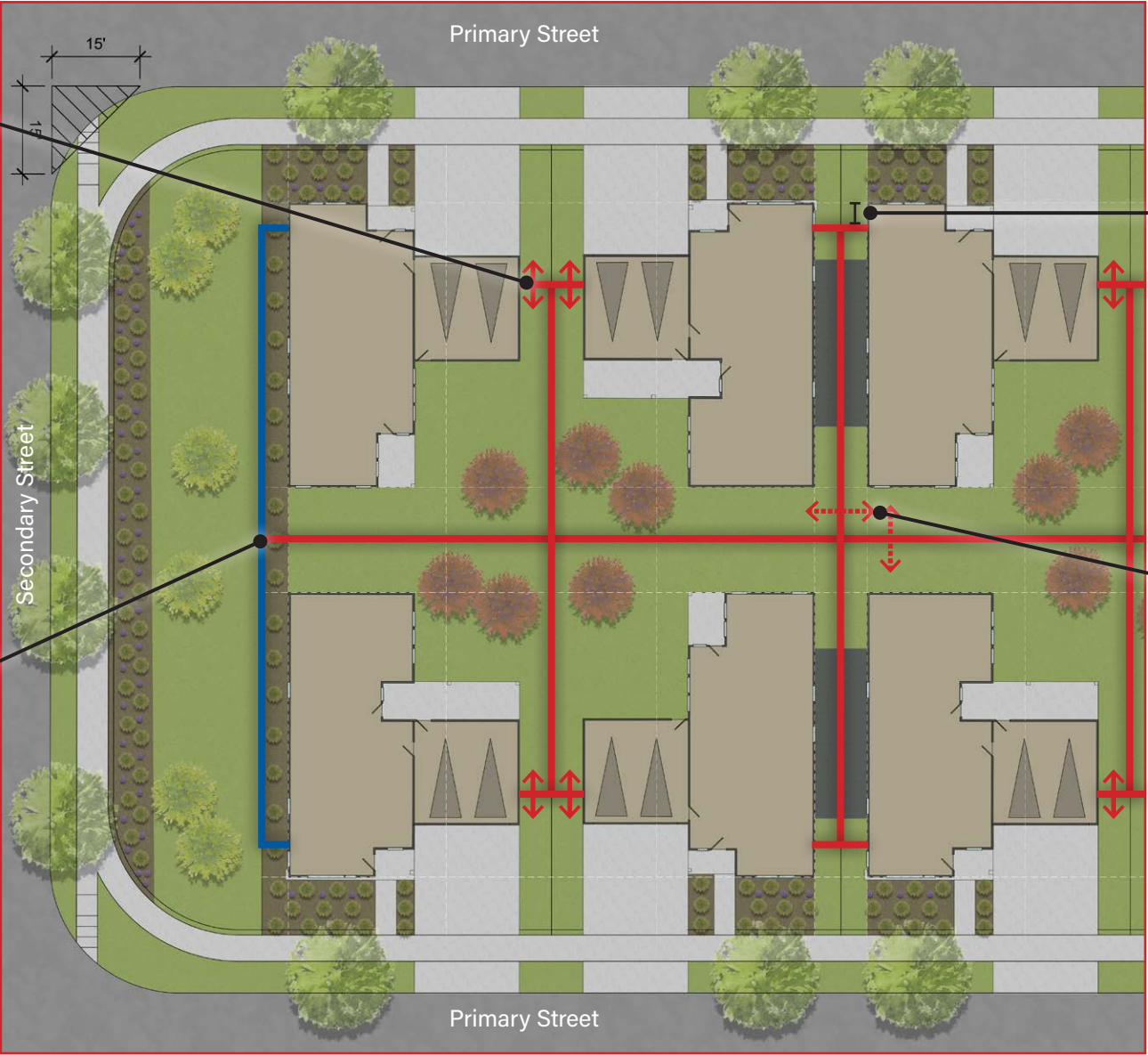

Gates shall be provided on the active side of lots

One gate access may be provided per lot facing the primary street. Additional gates may be provided on the passive side condition with approval from the ARC.

Fences shall coincide with property line

Gate access between adjacent lots is permitted if all affected property owners agree.

*Fences may be excluded if all adjacent property owners agree; however, no permanent improvements may straddle property lines or encroach utility easements.

Note: See Fence + Gate details at end of this chapter

FUNDAMENTAL + WATER CONSERVATION

Landscape installation and long-term maintenance depend on appropriate planning before anything goes in the ground. Some principles for accomplishing a successful landscape include:

- Design and install landscaping in a timely fashion
- Locate plants to prevent water damage, prevent soils exposure, and stabilize slope banks
- Conserve water and provide coordinated landscape irrigation systems geared towards the needs of different plant species
- Harmonize mulch type, size, and color between individual lots

Plant Location

Cluster trees adjacent to the home as opposed to straddling the property line

Use the following methods to prevent water into the home's foundations:

- Design and locate roof drain gutters to convey stormwater away from building foundations and associated foundation plantings
- Grade the ground around the home to slope away from the foundation

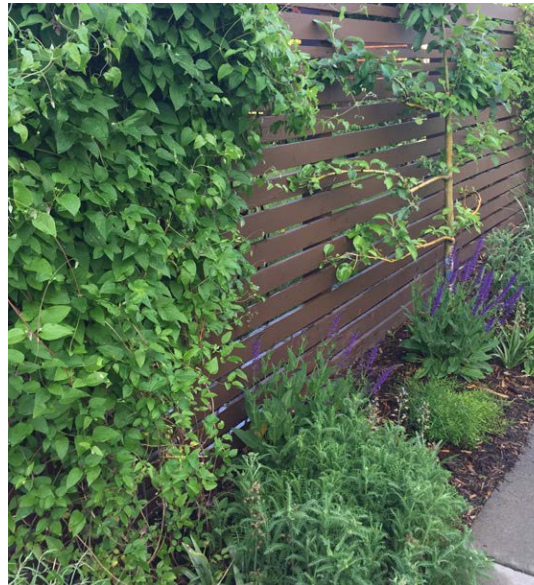

Utilize the landscape strip between the sidewalk and the fence to plant shrubs and perennials. Landscape materials should be vining or more vertical so as not to infringe on the walk. Refer to the plant materials list at the end of this chapter for preferred plant selections (additional plants may be approved by the ARC).

Planting Beds

- Planting bed "islands" (surrounded by turf) are discouraged.
- Planting Beds shall not be rectangular in shape unless bounded by architecture or paving on all sides.
- Plant shrubs, ground-covers, and flower beds to cover fifty percent of the shrub or flower bed within three years
- Mulch planting beds to discourage weed growth with wood mulch
- Use wood mulch to mulch perennial and annual flowerbeds covering any bare ground

Irrigation

Design irrigation systems with 100% coverage on beds and turf to minimize over-spray and water-waste. Limit overhead spray irrigation to turf/sod grasses and flowering ground cover areas. All other areas shall use drip irrigation. Maximize irrigation areas. The recommended minimum width of spray areas shall be six feet. Use low angle spray nozzles (45 degrees) adjacent to paved areas. Irrigation is required on all landscaped areas (excluding black star gravel in side yards).

Turf + Sod

Turf/grass sod shall be required on all private property instead of seeding, which can promote weed growth and inconsistent coverage

Edging Materials

Shrub bed edges may be spaded or may use aluminum edging materials. No other edging materials are permitted.

FUNDAMENTAL + WATER CONSERVATION

Mulch

All planted areas shall be mulched with a brown hardwood, mulch 2"-3" deep. Add mulch to planting beds as necessary to maintain a mulch layer throughout the year

Water Conservation

Encourage landscapes that are designed to conserve water, harmonizing with the regional and individual lot micro-climate conditions. Group plants based on water needs. Use plants, drip irrigation systems, and maintenance practices that conserve water.



Landscape Walls

For elevated shrub beds, landscape walls may be permitted by the ARC. Landscape wall material must match or relate to the architecture (dry-stacked stone walls and other loose materials are not permitted). Landscape walls should be no more than 24" in height (greater heights may be approved by the ARC).

Soil

Due to the impact of construction on soil quality and structure, soil amendments with organic fertilizers and quality compost shall be required. These measures ensure healthy soils, reduce water requirements, reduce fertilization needs, and support healthier plant life.

Conservation

In addition to water conservation, efforts shall be made throughout development to utilize locally sourced materials and renewable resources.

Utilities

Utilities and utility meters shall be located prior to any landscape improvements including fencing. If utility boxes occur on an owner's property and are not otherwise screened from public view, the homeowner shall screen boxes with 3' height minimum shrubs.

Decorative Pots

Decorative pots are allowed; however, pots shall be style appropriate, of a quality material, and limited as to not appear cluttered. Review of decorative pots is at the discretion of the ARC.

SITE IMPROVEMENTS

Retaining Walls

Residential retaining walls, throughout Easthaven, shall have the same character and style. In all cases, planting shall be used to soften the appearance of the wall. Retaining walls shall have a smooth concrete finish (to match master developer specification). For unique conditions, approval through the ARC will be required. Design and character of retaining wall shall be consistent regardless of Architectural styles.

Standard Retaining Wall

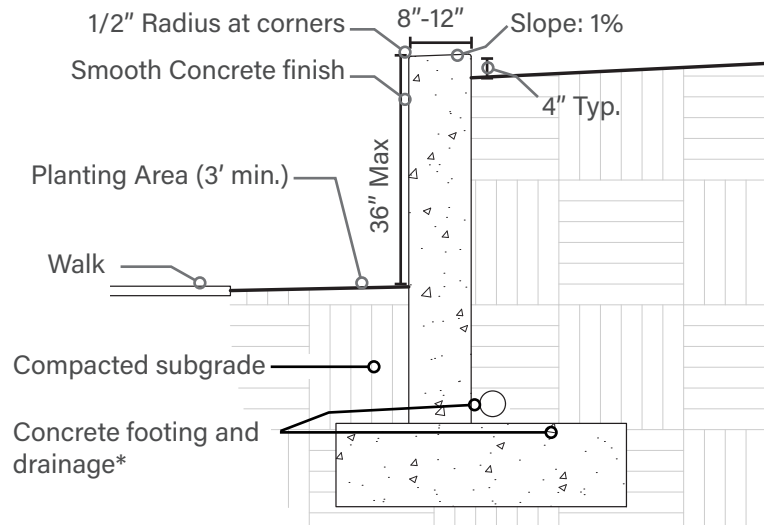

*All fence and wall details shall be verified per manufacturer's recommendations or structural engineer as applicable



SITE IMPROVEMENTS

IV.69



Lighting

Lighting for safety and aesthetics may be allowable in Bridgeland Central Easthaven.

Standards:

Outdoor lighting may be installed according to the following requirements:

Front lots: All porches shall have at least one recessed down-light or sconce over the porch and shall be mounted under the soffit. Bare bulbs, except for Edison bulbs, are not allowed on exterior applications visible from the street, public sidewalks or adjacent properties. Floodlighting is not allowed.

Private landscape areas: additional outdoor lighting in the form of recessed down-lights, wall sconces, and shielded wall-mounted lights are acceptable. Light shall be on a timed system that turns off by 11 pm. Flood lights are not allowed. Up-lights are allowable to highlight trees and architectural features providing that they are shielded to hide the source. Tree up-lights shall be limited to 20 watts per tree. String/festoon lighting or other low level mood lighting shall be allowed in the rear yards. Lighting must be warm white in the 3000-3500K temperature range. Under soffit lighting on the side of homes and on the second story on rear of homes that have adjacent homes sites is prohibited.



FENCING + GATES

Steel Tube Fence

Steel Tube Fences shall be five feet (5'-0") tall with vertical metal slats. The joints shall be constructed in such a way that neither neighbor will have exposed joints and hardware.

General Notes

1. Tube steel fence shall be v2 ft/fb2 commercial fence (flat top, flat bottom) as provided by fortress fence products.
2. Fence shall be pool barrier compliant.
3. Reference manufacturer's recommendations for installation regarding wind load capacity, footing depth, and bracket attachments.
4. Awn per manufacturer's specifications, fence panels may not be installed on a slope greater than 21°.

Design Requirements

Steel Tube Fencing

Steel Tube Fence Requirements:

- Height: 5'-0"
- Vertical Pattern Pattern (See Exhibit):
- 3/4" tubes; 3 15/16" gaps
- Ground Clearance: 2" min.
- Post Spacing: 95" O.C.

Gate Requirements:

- Tube Pattern (See Exhibit)
 - 3/4" tube; 3-15/16" gap
- Ground Clearance: 2" (minimum)
- Gate Opening: 4"
- Gate Width: 3'-8"
- Hardware: refer to Manufacturer's Recommendations

Steel Tube Fence

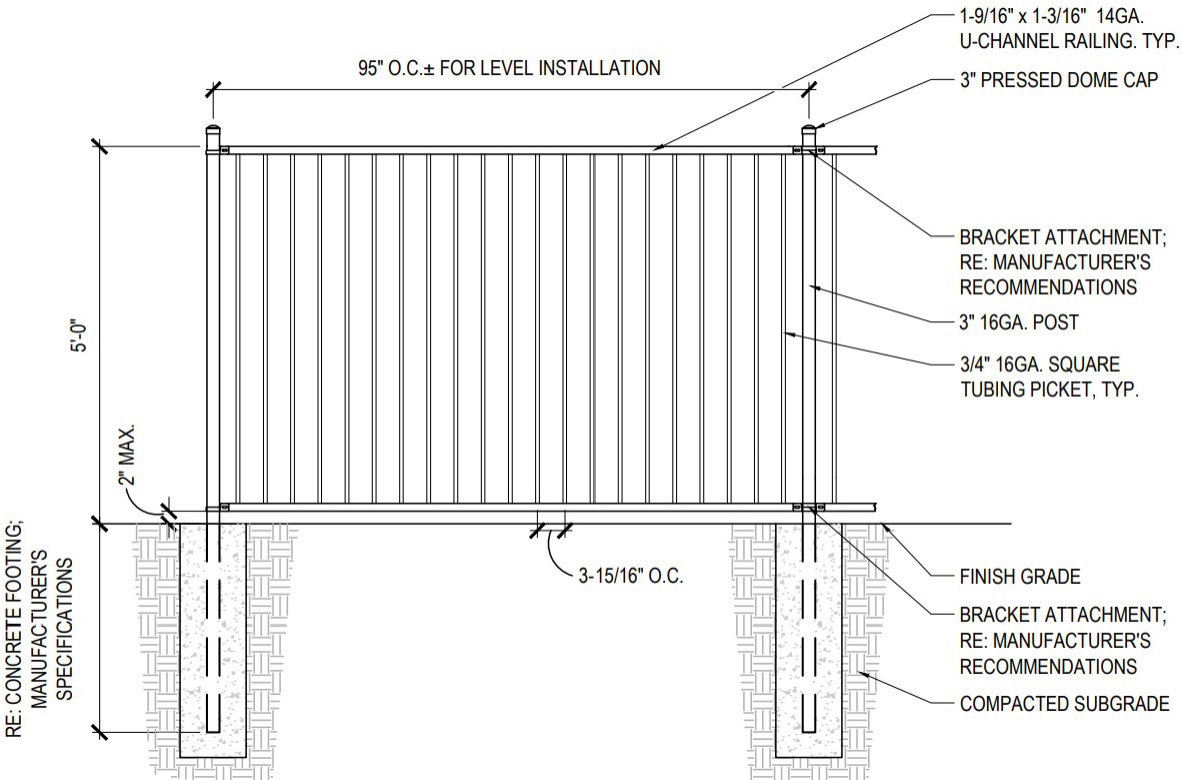

Gate Details

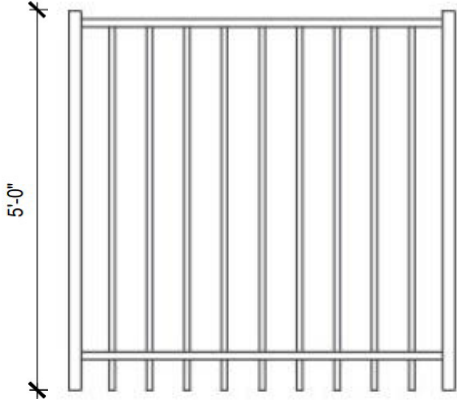

FENCING + GATES

Horizontal Wood Fence

Horizontal Wood Fence shall be five feet (5'-0") tall with horizontal wood slats. The joints shall be constructed in such a way that neither neighbor will have exposed joints and hardware.

General Notes

1. All wood shall be rough sawn cedar. Stain shall be Sikken's 058-Oxford Brown and shall be approved by the ARC prior to use. All fencing within the community shall be stained the same color.
2. All gate hardware shall be black.
3. Provide minimum 2" clear (4" maximum) between bottom rail of fence and finish grade.
4. Post spacing shall be 6'-0" O.C.
5. Fasteners shall be galvanized screws/nails.



Design Requirements

Horizontal Wood Fencing

Horizontal Wood Requirements:

1. Height: 5'
2. Horizontal Slat Pattern (See Exhibit):
3. 6" Slat-1" Space-4" Slat-1" Space-4" Slat
4. Ground Clearance: 2"-4"
5. Fence/Post Cap: 2" Lateral Slat (1" overhang)
6. Post Spacing: 6'-0" O.C.

Gate Requirements:

- Slat Pattern (See Exhibit)
 - 4" slat; 1" gap
- Ground Clearance: 2" (2" minimum)
- Gate Opening: 4'
- Gate Width: 3'-9"
- Hardware: (2) T-Hinges; (1) Latch

Horizontal Wood Fence

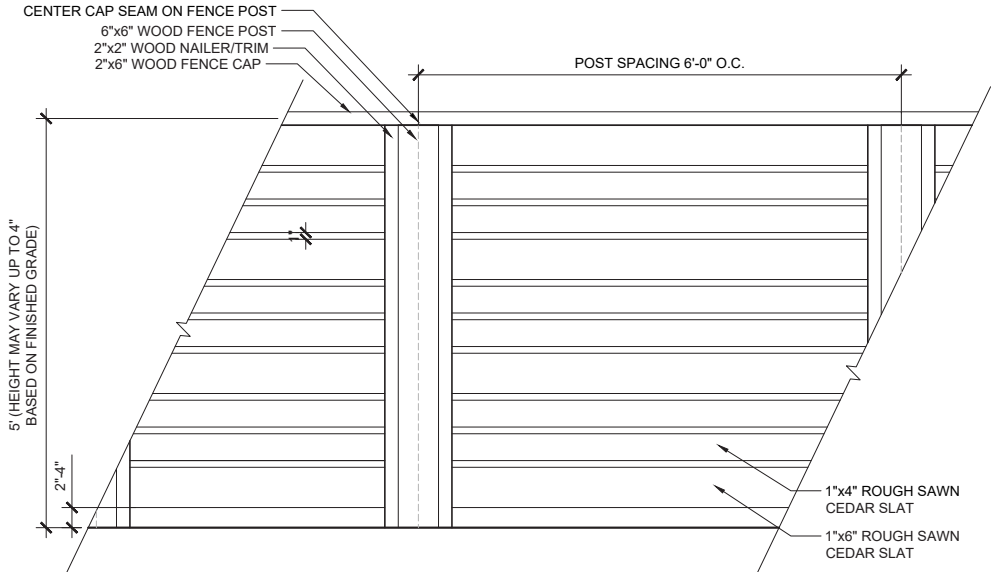

Horizontal Wood Gate

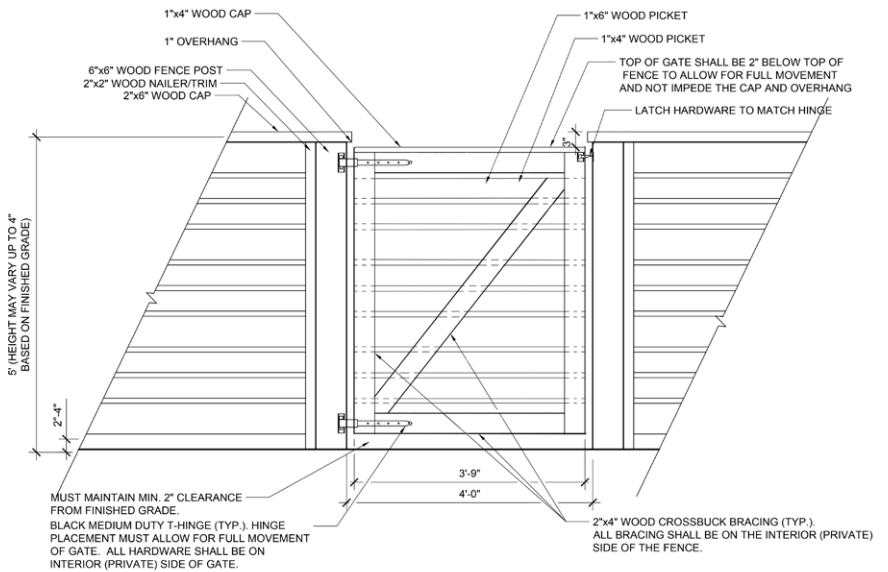

Fence Details

Plan View of Fence

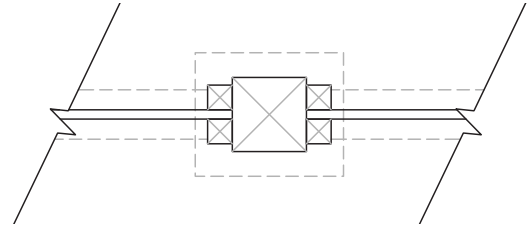

Fence Footing

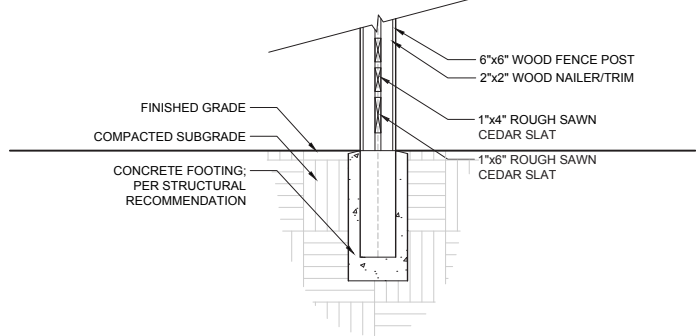

PLANT MATERIALS

Botanical Name	Common Name	Min. Size
Screening Planting		
<i>Feijoa sellowiana</i>	Pineapple Guava	15 gal.
<i>Ilex x attenuata</i>	Holly (shrub form) varieties include Eaglestone East Palatka	15 gal. 15 gal.
<i>Ilex vomitoria</i>	Yaupon Holly (shrub form) varieties include Pride of Houston	15 gal.
<i>Myrica cerifera</i>	Wax Myrtle (shrub form) varieties include Nana	15 gal.
<i>Pinus taeda</i>	Loblolly Pine (trees to be mixed with shrubs)	30 gal.
<i>Podocarpus macrophyllus</i>	Japanese Yew	30 gal.
<i>Prunus laurocerasus</i>	Cherry Laurel	15 gal.
<i>Viburnum suspensum</i>	Sandankwa Viburnum	10 gal.



PLANT MATERIALS

IV.75

Botanical Name	Common Name	Min. Size	
Shrubs			
Anisacanthus quadrifidus Wrightii	Flame Acanthus	3 gal.	30" on center
Buddleia davidii 'Dubonett'	Dubonett Butterfly Bush	3 gal.	30" on center
Buxus microphylla	Boxwood	3 gal.	24" on center
Callicarpus americana	American Beautyberry	3 gal.	30" on center
Callistemon citrinus 'Little John'	Dwarf Bottlebrush	3 gal.	24" on center
Cephalanthus occidentalis	Buttonbush	3 gal.	30" on center
Feijoa sellowiana	Pineapple Guava (shrub form)	5 gal.	36" on center
Ilex cornuta 'Carissa'	Carissa Holly	5 gal.	30" on center
Itea virginica	Virginia Sweetspire	3 gal.	24" on center
Malvaviscus arboreus var. Drummondii	Turk's Cap	3 gal.	30" on center
Myrica cerifera	Dwarf Wax Myrtle	5 gal.	24" on center
Podocarpus microphyllus	Japanese Yew variety includes Pringles	5 gal	30" on center
Sabal minor (rear yard, massing only)	Dwarf Palmetto	3 gal.	36" on center
Viburnum suspensum	Sandankwa Viburnum	5 gal.	30" on center
Viburnum obovatum	Walter Viburnum	5 gal.	30" on center



PLANT MATERIALS

Botanical Name	Common Name	Min. Size	
Perennials			
Agapanthus	Lily of the Nile	3 gal.	18" on center
Asclepias incarnata	Swamp Milkweed	3 gal.	18" on center
Asparagus densiflorus	Foxtail Fern	3 gal.	18" on center
	varieties includes Myers		
Dianella tasmanica 'Variegata'	Variegated Flax Lily	3 gal.	18" on center
Dietes bicolor	Bicolor Iris	3 gal.	18" on center
Eupatorium greggi	Greggii Mistflower	3 gal.	18" on center
Hesperaloe parviflora	Red Yucca	3 gal.	30" on center
Liriope gigantea	Giant Liriope	3 gal.	18" on center
Plumbago auriculata	Plumbago	3 gal.	24" on center
Rudbeckia hirta	Black-Eyed Susan,	3 gal.	18" on center
	varieties include Goldsturm		
Salvia	Salvia, varieties include	3 gal.	24" on center
	Indigo Spires, Black and Bloom		
Salvia leucantha	Mexican Bush Sage	3 gal.	24" on center
Tagetes lucida	Mexican Mint Marigold	3 gal.	18" on center
Ornamental Grasses			
Muhlenbergia capillaris	Gulf Coast Muhly	3 gal.	24" on center
	variety includes Regal Mist		
Muhlenbergia lindheimeri	Lindheimer Muhly	3 gal.	36" on center
Miscanthus sinensis	Dwarf Maiden Grass	3 gal.	36" on center
	varieties include Adagio,		
	Morning Light, Yakujima		
Panicum virgatum	Switch Grass	3 gal.	24" on center
	varieties include Shenandoah,		
	Heavy Metal, Northwind		

PLANT MATERIALS

IV.77

Botanical Name	Common Name	Min. Size	
Ground Cover			
<i>Ficus tikoua</i>	Sandi-Leaf Fig	1 gal.	12" on center
<i>Lantana montevidensis</i>	Purple Trailing Lantana	1 gal.	12" on center
<i>Lantana</i>	Lantana varieties includes New Gold	1 gal.	12" on center
<i>Ruellia</i>	Mexican Petunia	1 gal.	12" on center
<i>Trachelospermum asiaticum</i>	Asian Jasmine	1 gal.	12" on center
<i>Wedelia trilobata</i>	Wedelia	1 gal.	12" on center
Turf Grass			
Celebration Bermuda (Sod only)			
Vines			
<i>Ficus pumila</i>	Fig Ivy	1 gal.	12" on center
<i>Gelsemium sempervirens</i>	Carolina jessamine	1 gal.	12" on center
<i>Lonicera sempervirens</i>	Coral Honeysuckle	5 gal.	4' on center
Rose	Rose, varieties include Madame Alfred Carriere (nearly thornfree), New Dawn, Lady Banks White	5 gal.	6' on center
<i>Trachelospermum jasminoides</i>	Confederate Jasmine	1 gal.	12" on center







DESIGN REVIEW PROCESS

BRIDGELAND CENTRAL EASTHAVEN

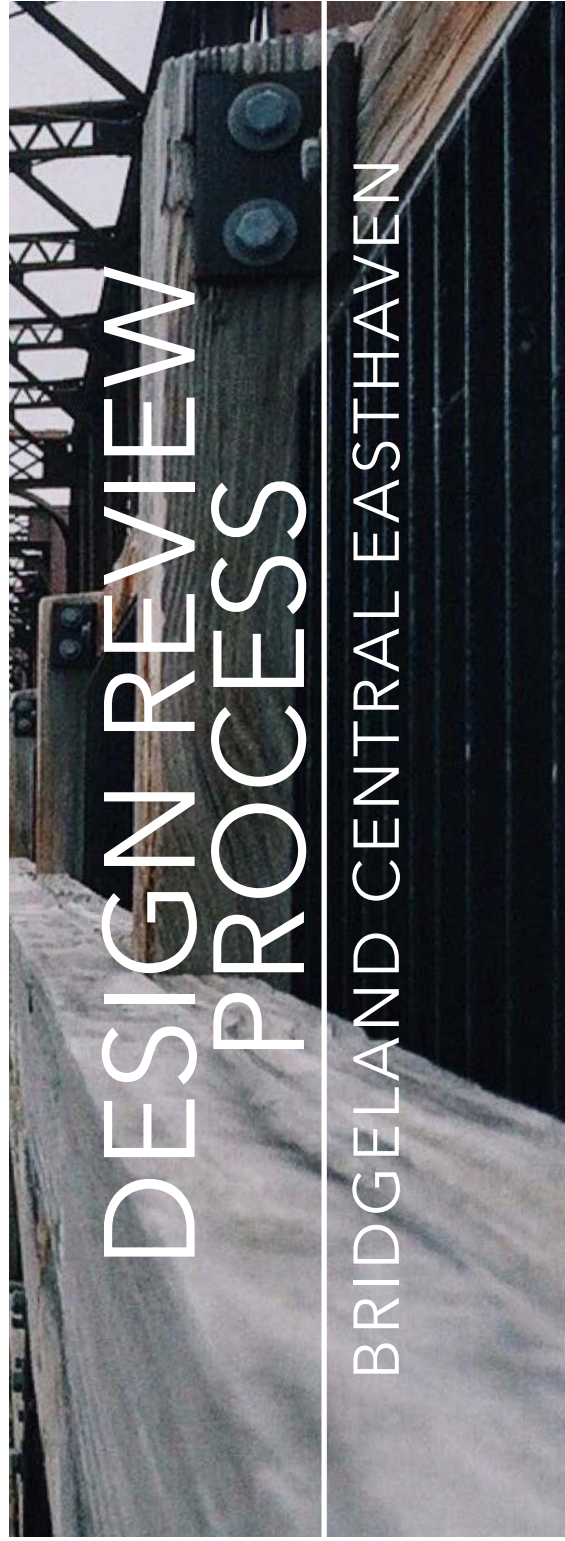

PROCEDURES & SUBMISSIONS

The Following Design Review Process text is extracted from the "Bridgeland Residential New Development Standards - Parkland" (3/16/2018). The full text is available online at: <<http://www.kenanderson.com/res-bridgeland>>

6.1 General

The process of submitting plans, specifications and samples to the Bridgeland Architectural Review Committee ("ARC.") is explained in this section. This process is intended as an instrument for insuring that builders maintain uniform conformance to the guidelines, which have been established to create a new town consistent with the Bridgeland Mission Statement. Within the stated time-period for review, a clear and direct statement as to acceptability of construction plans will be made to builders who make submissions in accordance with the standards.

The builder is solely responsible and liable for following the requirements of these Standards regardless of whether detail(s) of items are noted/called out on reviews/documentation including, but not limited to plans, permits, applications and inspections.

6.2 Scope of This Document

All new construction, subsequent construction, remodeling with exterior exposure, expansion, and demolition of structures within Bridgeland shall be reviewed and approved by the ARC, prior to commencement of any on-site building or construction activity. The ARC may consider any and all exterior elements of design including, but not limited to, size, massing, architectural style, colors, materials, harmony of design and other factors that, in the opinion of the ARC, affect the appearance of the improvement(s) and/or their compatibility with surrounding development.

This document specifically applies to the activities of Builders constructing new homes on lots on which there are no existing structures. A separate yet similar document will govern subsequent activities by homeowners or builders on lots once the initial construction activities have been completed.

6.3 Procedure

The review process begins when a Builder submits an online application including a set of plans, drawings, specifications and other required information to the ARC for processing. Submissions shall be made using the website below:
www.KenAnderson.com
Office: 281-367-5430

6.4 Required Submission Information

The builder is required to submit the following information to be reviewed by the ARC.

- A. Architectural
 - 1. Floor plans and (all) exterior elevations.
 - 2. Outline specifications with materials/colors list clearly referenced to location.
 - 3. Statement of House Square Footage. Note that ALL air-conditioned interior space, including, but not limited to, granny flats, shall be measured from interior stud to interior stud and be included in the house square footage.
- B. Site plot plan drawing including the following information:
 - 1. Village Name, Neighborhood Name, Section Number, Block Number, Lot Number.
 - 2. Right of way, minimum setbacks & easements.
- C. Master Plans
 - 1. In order to provide the shortest turnaround time for reviews the following shall be required. When submitting Master Plans for review, builders will submit each elevation as a separate submission. Each Master Plan (elevation) submission shall only include the plans, elevation, option, etc. sheets that pertain to that particular Master Plan (elevation).
 - 2. Actual footprint of house and garage, with dimensions of main elements from property line
 - 3. Driveway, patios, walls and any other flatwork, fully dimensioned
 - 4. Utility service locations
 - 5. Total area of all footprint areas of impervious cover including house and garage footprint
 - 6. Location, height and material of each exterior fence or wall
 - 7. Any proposed freestanding exterior lighting, including fixture cuts including locations, mounting heights and manufacturer's catalog photographs of proposed fixtures.
 - 8. Any temporary construction facilities such as trailers, storage locations, fences, temporary signs, lights, model home parking lots, etc.

PROCEDURES & SUBMISSIONS

6.5 Quality of Submission Content

It is in the interest of both the Builders and the Developer that this process be a smooth and timely one. Towards that end, the approvals can be facilitated if complete and high-quality documentation is provided to the ARC. When an Application is received, it is reviewed for completeness. An Application that is not complete and/or not clearly readable will be returned with an explanation of the reasons for this action. A complete Application will be processed and reviewed by the ARC.

6.6 Submission Timing

Submissions to the ARC for approval may be made at any time. Responses will generally be made within seven (7) business days from receipt of a completed online application (including all applicable supporting and required documents in electronic format), however there is no time restriction and lack of response shall be deemed a rejection.

6.7 Submission Fees

Nominal fees may be established by the Developer in the future to help defray the expenses associated with the review of improvements. The fees are adjusted from time to time and are based on the complexity of the project proposed. A list of current fees can be obtained from the Developer's office.

6.8 ARC Action on Submittals

The approval process is intended to minimize hardship or undue delays, while facilitating the common goals of the Builders and the Developer. Every effort will be made to review and act upon applications as soon as possible after they are received.

Notice of Approval, Conditional Approval or Disapproval of each submission will be returned to the Applicant via email or other electronic means which the ARC deems appropriate. Construction may proceed immediately following receipt of written Final Building Permit Approval from the ARC.

6.9 Expiration of Permits

All approved or conditionally approved permits shall be exercised within one (1) year from the date of approval, or the permit shall be null and void.

6.10 Variances

Variances to these Standards may be granted by the ARC. Any variance granted will only be applicable to the specified site and conditions for which the variance was granted, only if it has been identified in writing on the submitted plan and specifically approved in writing by the ARC. Granting of such a variance will not modify or change any standards as they apply to other lots or conditions.

All variances shall be exercised within one (1) year from the date of approval, or the variance shall be null and void. Upon an application, which must be submitted in writing thirty (30) days prior to the expiration and for good cause, the ARC may grant an extension of time not to exceed one (1) year.

6.11 Appeals

Every aspect of a proposal is carefully weighed and most projects are approved. If a proposed submission is not approved by the ARC, the applicant may appeal the decision to the ARC in writing within ten (10) days of receipt of the ARC decision. Appeal can be made by addressing a letter to the ARC stating the decision being appealed and the specific objection to the decision. The ARC then hears and rules on appeal as promptly as possible. All decisions of the ARC are final.

6.12 Construction Timeline

Construction of dwellings, which have received prior written approval or conditional approval by the ARC, shall commence within one (1) year of the permit date and shall be completed within:

- Production Home - One (1) Year
- Custom Home - Two (2) Years

The ARC may grant an extension for

construction on a case-by-case basis, but the request for an extension must be made at least thirty (30) business days prior to the conclusion of the completion deadlines noted above.

Failure to complete a home within the designated time period may result in a penalty or fine to be drawn from the builder's construction deposit and/or damage deposit.

6.13 Final Compliance Inspection Procedures, Penalties, and Variances

A representative of the ARC must inspect the improvements to verify that they have been constructed in conformance with the Covenants, the approved plans and these Development Standards. The Final Compliance Inspection represents a selected portion of these Development Standards; it should not be considered as a total approval of these Development Standards. Inspections conducted by Bridgeland, the ARC and/or Ken Anderson & Associates are aesthetically based only and in no way, include inspections pertaining to code compliance or to the integrity of the home and/or improvements. Builders are solely responsible and liable for ensuring that all construction and/or improvements meet or exceed all applicable codes, good building practices and comply with all local and federal regulations, laws, etc. Each builder is ultimately responsible to make sure every home is built to be in

PROCEDURES & SUBMISSIONS

full compliance with these Development Standards.

D. Inspection Procedures and Penalties

1. Request for Initial Final Compliance Inspection

Once a home is completed, each Builder is responsible for making a request to the ARC for a Final Compliance Inspection, using the online request services at www.KenAnderson.com. Request for a Final Compliance Inspection must be made at least seven (7) days before the home closes.

A final survey (including all fences, pools and other installed improvements) must be submitted to the ARC at the time the Final Compliance Inspection request is made. Anyone who fails to meet the requirements will be subject to a five-hundred (\$500.00) dollar fine, which may be deducted from the Builder's construction deposit and/or damage deposit.

If the property does not pass its initial Final Compliance Inspection, the builder will have ten (10) working days to correct all items listed on the Final Compliance Inspection report. It is the builder's responsibility to request a re-inspection once the necessary corrections have been completed

otherwise a re-inspection will be conducted automatically after the ten (10) working days have expired.

2. 2nd Final Compliance Inspection (Re-Inspection)

If the property does not pass its 2nd Final Compliance Inspection, the builder will have ten (10) working days to correct all items listed on the Final Compliance Inspection report. It is the builder's responsibility to request a re-inspection once the necessary corrections have been completed otherwise a re-inspection will be conducted automatically after the ten (10) working days have expired.

3. 3rd Final Compliance Inspection (Re-Inspection)

The property will be inspected one final time. If all outstanding items have not been corrected, the following will occur:

- The builder will be issued a Final Compliance Inspection verdict of "Closed Non-Compliant" and a copy will be sent to the Bridgeland HOA.
- All New Construction Submittals/Building Permits (starts) will be put on hold company-wide until all outstanding inspection items

are brought into compliance.

- Responsibility for bringing all outstanding items into compliance will be transferred from the builder to the Homeowner and resolution may be enforced through the HOA as a request to comply with the New Construction Development Standards.
- When necessary the HOA will inform the Homeowners that the home was inspected multiple times to allow the builder to bring the outstanding items into compliance, and that it was the Builders responsibility to make sure that all construction requirements were met before the home closed.

6.14 Remedies

Additional remedies and enforcement rights exist under the Covenants. The ARC may file suit to obtain an injunction mandating compliance with the Covenants and the Standards. The ARC has the further right, after proper notice to the Owner, to go onto the property where a violation exists, fix or remove the violation, and collect any costs incurred from the Owner.

6.15 Changes in Review Process

The ARC reserves the right to alter the review process in order to ensure an adequate review of all submissions while reasonably accommodating the needs of Builders.

6.16 Governmental Regulations

The Covenants and these Development Standards are not intended to permit any action prohibited by applicable laws, rules, or regulations of any governmental authority. Where these Standards contain requirements in addition to or more restrictive than applicable governmental laws or regulations, the provisions of these Standards are binding and enforceable, and prevail over the requirements of such laws or regulations unless these Standards are expressly made unenforceable by law or judicial decisions.



dtj
DESIGN

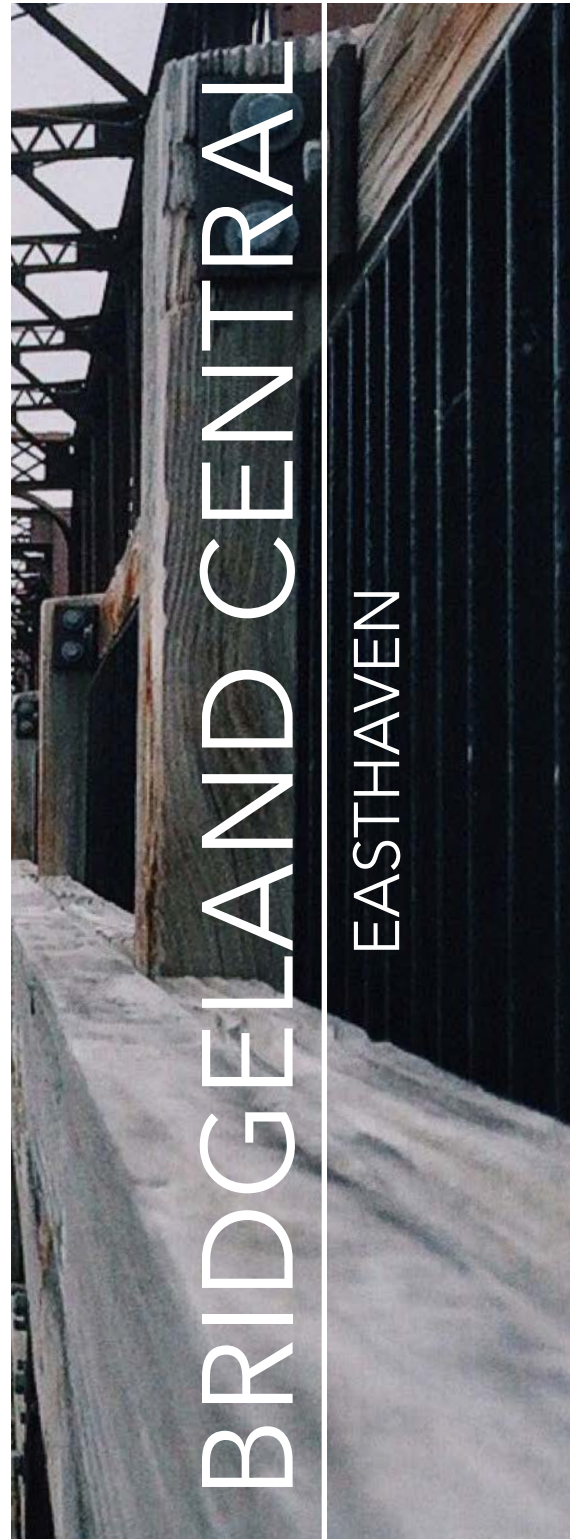

BRIDGELAND CENTRAL

EASTHAVEN